

# **GURUNANAK INSTITUTE OF TECHNOLOGY**

157/F, Nilgunj Road, Panihati Kolkata -700114

Website: [www.gnit.ac.in](http://www.gnit.ac.in)

Email: [info.gnit@jisgroup.org](mailto:info.gnit@jisgroup.org)

Approved by A.I.C.T.E., New Delhi  
Affiliated to MAKAUT, West Bengal

## **Online Courseware**

**Course: Satellite and Optical Communication**

**Code: EC701A (R18)**

**Course Level: Undergraduate**

**Credit: 3**

**Prepared by: Dr. Sunipa Roy**  
**Associate Professor, ECE**



# SATTELITE SYSTEM

## CHAPTER 1

### 1.1 Introduction:-

Satellites offer a number of features not readily available with other means of communications. Because very large areas of the earth are visible from a satellite, the satellite can form the star point of a communications net, simultaneously linking many users who may be widely separated geographically. The same feature enables satellites to provide communications links to remote communities in sparsely populated areas that are difficult to access by other means. Of course, satellite signals ignore political boundaries as well as geographic ones, which may or may not be a desirable feature.

Satellites are also used for remote sensing, examples being the detection of water pollution and the monitoring and reporting of Chapter One weather conditions. Some of these remote sensing satellites also form a vital link in search and rescue operations for downed aircraft and the like. Satellites are specifically made for telecommunication purpose. They are used for mobile applications such as communication to ships, vehicles, planes, hand-held terminals and for TV and radio broadcasting. They are responsible for providing these services to an assigned region (area) on the earth. The power and bandwidth of these satellites depend upon the preferred size of the footprint, complexity of the traffic control protocol schemes and the cost of ground stations. A satellite works most efficiently when the transmissions are focused with a desired area. When the area is focused, then the emissions do not go outside that designated area and thus minimizing the interference to the other systems. This leads more efficient spectrum usage.

Satellite's antenna patterns play an important role and must be designed to best cover the designated geographical area (which is generally irregular in shape). Satellites should be designed by keeping in mind its usability for short and long term effects throughout its life time. The earth station should be in a position to control the satellite if it drifts from its orbit it is subjected to any kind of drag from the external forces.

## **1.2 History of Satellite Communications**

The first artificial satellite used solely to further advances in global communications was a balloon named Echo 1. Echo 1 was the world's first artificial communications satellite capable of relaying signals to other points on Earth. The first American satellite to relay communications was Project SCORE in 1958, which used a tape recorder to store and forward voice messages. It was used to send a Christmas greeting to the world from U.S. President Dwight D. Eisenhower. NASA launched the Echo satellite in 1960; the 100-foot (30 m) aluminised PET film balloon served as a passive reflector for radio communications. Courier 1B, built by Philco, also launched in 1960, was the world's first active repeater satellite. The first communications satellite was Sputnik 1. Put into orbit by the Soviet Union on October 4, 1957, it was equipped with an onboard radio-transmitter that worked on two frequencies: 20.005 and 40.002 MHz. Sputnik 1 was launched as a step in the exploration of space and rocket development. While incredibly important it was not placed in orbit for the purpose of sending data from one point on earth to another. And it was the first artificial satellite in the steps leading to today's satellite communications. Telstar was the second active, direct relay communications satellite. Belonging to AT&T as part of a multi-national agreement between AT&T, Bell Telephone Laboratories, NASA, the British General Post Office, and the French National PTT (Post Office) to develop satellite communications, it was launched by NASA from Cape Canaveral on July 10, 1962, the first privately sponsored space launch. Relay 1 was launched on December 13, 1962, and became the first satellite to broadcast across the Pacific on November 22, 1963.

## CHAPTER 2: ORBITAL MECHANICS

Satellites (spacecraft) orbiting the earth follow the same laws that govern the motion of the planets around the sun. From early times much has been learned about planetary motion through careful observations. Johannes Kepler (1571–1630) was able to derive empirically three laws describing planetary motion. Later, in 1665, Sir Isaac Newton (1642–1727) derived Kepler's laws from his own laws of mechanics and developed the theory of gravitation.

### 2.1 Kepler's Laws of Planetary Motion

**Kepler's First Law:-** *Kepler's first law* states that the path followed by a satellite around the primary will be an ellipse. An ellipse has two focal points shown as  $F_1$  and  $F_2$  in Fig.1.

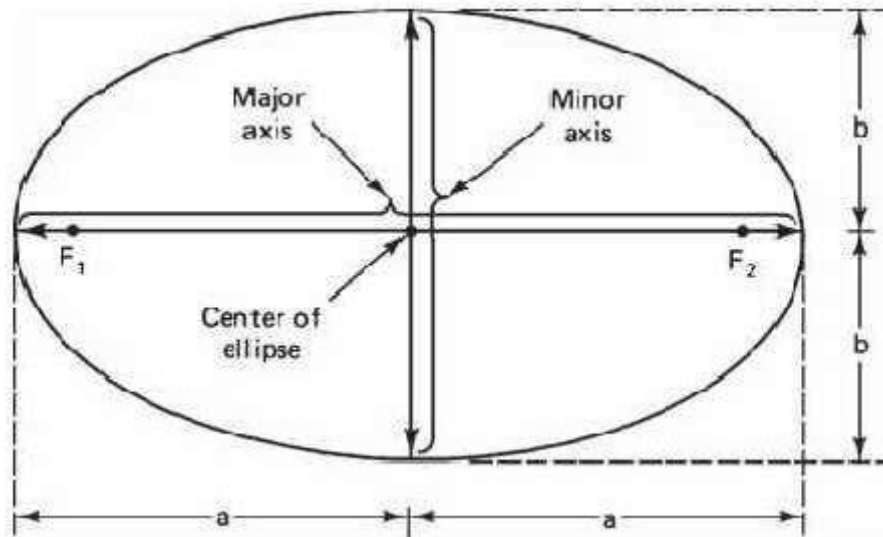
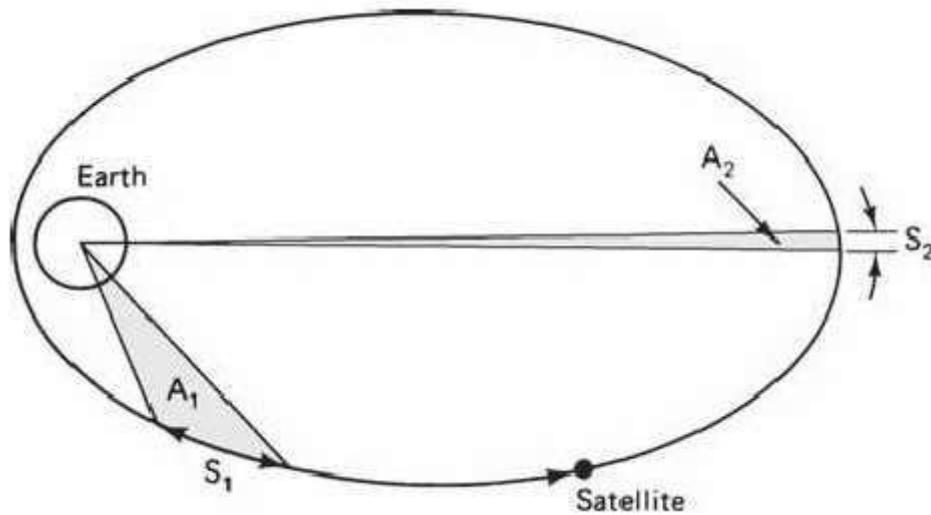

Fig.2.1 The foci  $F_1$  and  $F_2$ , the semimajor axis  $a$ , and the semiminor axis  $b$  of an ellipse

The foci  $F$  The eccentricity and the semimajor axis are two of the orbital parameters specified for satellites (spacecraft) orbiting the earth. For an elliptical orbit,  $0 < e < 1$ . When  $e = 0$ , the orbit becomes circular.

**Kepler's Second Law:-** *Kepler's second law* states that, for equal time intervals, a satellite will sweep out equal areas in its orbital plane, focused at the barycenter. The center of mass of the two-body system, termed the *barycenter*, is always centered on one of the foci.



**Figure 2.2.** Kepler's second law. The areas  $A_1$  and  $A_2$  swept out in unit time are equal.

**Kepler's Third Law:-** *Kepler's third law* states that the square of the periodic time of orbit is proportional to the cube of the mean distance between the two bodies. The mean distance is equal to the semimajor axis  $a$ . For the artificial satellites orbiting the earth, Kepler's third law can be written as follows

$$a^3 = \frac{\mu}{n^2} \quad \dots (1)$$

where  $n$  is the mean motion of the satellite in radians per second and  $\mu$  is the earth's geocentric gravitational constant.

$$\mu = 3.986005 \times 10^{14} \text{ m}^3 / \text{s}^3 \quad \dots (2)$$

The importance of Kepler's third law is that it shows there is a fixed relationship between period and semimajor axis.

## 2.2 Satellite Orbits

There are many different satellite orbits that can be used. The ones that receive the most attention are the geostationary orbit used as they are stationary above a particular point on the Earth. The orbit that is chosen for a satellite depends upon its application. These orbits are given in table 1.

## Geostationary or geosynchronous earth orbit (GEO)

A satellite in a geostationary orbit appears to be stationary with respect to the earth, hence the name *geostationary*. GEO satellites are synchronous with respect to earth. Looking from a fixed point from Earth, these satellites appear to be stationary. These satellites are placed in the space in such a way that only three satellites are sufficient to provide connection throughout the surface of the Earth. GEO satellite travels eastward at the same rotational speed as the earth in circular orbit with zero inclination.

A geostationary orbit is useful for communications because ground antennas can be aimed at the satellite without their having to track the satellite's motion. This is relatively inexpensive. In applications that require a large number of ground antennas, such as [DirectTV](#) distribution, the savings in ground equipment can more than outweigh the cost and complexity of placing a satellite into orbit.

**Table: 1**

STELLITE ORBIT NAME	ORBIT	SATELLITE ORBIT ALTITUDE (KM ABOVE EARTH'S SURFACE)	APPLICATION
Low Earth Orbit	LEO	200 - 1200	Satellite phones, Navstar or Global Positioning (GPS) system
Medium Earth Orbit	MEO	1200 - 35790	High-speed telephone signals
Geosynchronous Orbit	GSO	35790	Satellite Television
Geostationary Orbit	GEO	35790	Direct broadcast television

## Low Earth Orbit (LEO) satellites

A low Earth orbit (LEO) typically is a circular orbit about 200 kilometres (120 mi) above the earth's surface and, correspondingly, a period (time to revolve around the earth) of about 90 minutes. Because of their low altitude, these satellites are only visible from within a radius of roughly 1000 kilometers from the sub-satellite point. In addition, satellites in low earth orbit change their position relative to the ground position quickly. So even for local applications, a large number of satellites are needed if the mission requires uninterrupted connectivity. s. LEO systems try to ensure a high elevation for every spot on earth to provide a high quality

communication link. Each LEO satellite will only be visible from the earth for around ten minutes.

Low-Earth-orbiting satellites are less expensive to launch into orbit than geostationary satellites and, due to proximity to the ground, do not require as high signal strength (Recall that signal strength falls off as the square of the distance from the source, so the effect is dramatic). Thus there is a trade off between the number of satellites and their cost. In addition, there are important differences in the onboard and ground equipment needed to support the two types of missions. One general problem of LEOs is the short lifetime of about five to eight years due to atmospheric drag and radiation from the inner Van Allen belt.

### **Medium Earth Orbit (MEO) satellites**

A MEO satellite is in orbit somewhere between 8,000 km and 18,000 km above the earth's surface. MEO satellites are similar to LEO satellites in functionality. MEO satellites are visible for much longer periods of time than LEO satellites, usually between 2 to 8 hours. MEO satellites have a larger coverage area than LEO satellites. A MEO satellite's longer duration of visibility and wider footprint means fewer satellites are needed in a MEO network than a LEO network. One disadvantage is that a MEO satellite's distance gives it a longer time delay and weaker signal than a LEO satellite, though not as bad as a GEO satellite. Due to the larger distance to the earth, delay increases to about 70–80 ms. so these satellites need higher transmit power and special antennas for smaller footprints.

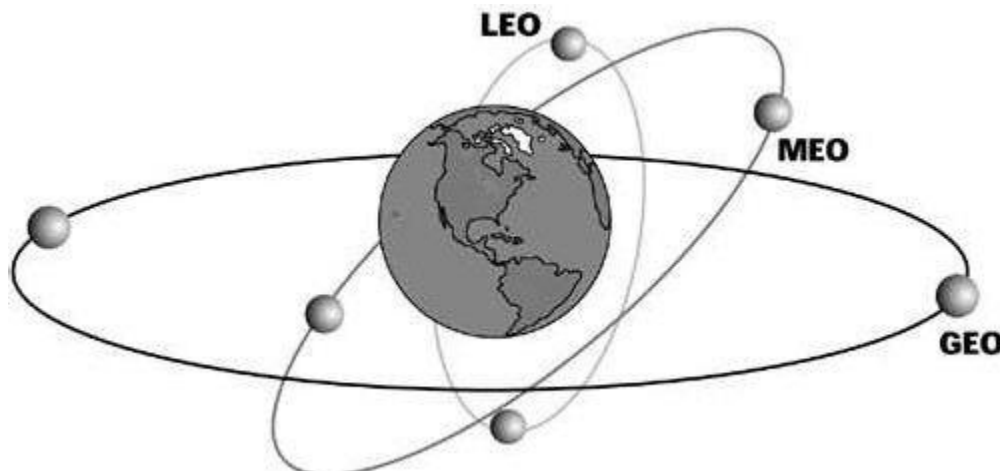

**Fig. 2.3 Satellite Orbits**

## 2.3 Spacing and Frequency Allocation

Allocating frequencies to satellite services is a complicated process which requires international coordination and planning. This is carried out under the supervision of the *International Telecommunication Union* (ITU). This frequency allocation is done based on different areas. So this world is divided into three areas.

Area 1:- : Europe, Africa, Soviet Union, and Mongolia

Area 2: North and South America and Greenland

Area 3: Asia (excluding area 1 areas), Australia, and the south-west Pacific

Within these regions, frequency bands are allocated to various satellite services, although a given service may be allocated different frequency bands in different regions. Some of the services provided by satellites are:

- ***Fixed satellite service (FSS)***

The FSS provides links for existing telephone networks as well as for transmitting television signals to cable companies for distribution over cable systems. Broadcasting satellite services are intended mainly for direct broadcast to the home, sometimes referred to as *direct broadcast satellite* (DBS) service [in Europe it may be known as *direct-to-home* (DTH) service]. Mobile satellite services would include land mobile, maritime mobile, and aeronautical mobile. Navigational satellite services include *global positioning systems* (GPS), and satellites intended for the meteorological services often provide a search and rescue service.

**TABLE 2: ITU Frequency Band Designations**

Band number	Symbols	Frequency range (lower limit exclusive, upper limit inclusive)
4	VLF	3–30 kHz
5	LF	30–300 kHz
6	MF	300–3000 kHz
7	HF	3–30 MHz
8	VHF	30–300 MHz
9	UHF	300–3000 MHz
10	SHF	3–30 GHz
11	EHF	30–300 GHz
12		300–3000 GHz

**TABLE 3: Frequency Band Designations**

Frequency range, (GHz)	Band designation
0.1–0.3	VHF
0.3–1.0	UHF
1.0–2.0	L
2.0–4.0	S
4.0–8.0	C
8.0–12.0	X
12.0–18.0	Ku
18.0–27.0	K
27.0–40.0	Ka
40.0–75	V
75–110	W
110–300	mm
300–3000	μm

- **Broadcasting satellite service (BSS)**  
Provides Direct Broadcast to homes. E.g. Live Cricket matches etc.
- **Mobile satellite services**
  - Land Mobile
  - Maritime Mobile
  - Aeronautical mobile
- **Navigational satellite services**
  - Include Global Positioning systems
- **Meteorological satellite services**
  - They are often used to perform Search and Rescue service.

## 2.4 Look Angle Determination

The satellite look angle refers to the angle that one would look for a satellite at a given time from a specified position on the Earth. The look angles for the ground station antenna are Azimuth and Elevation angles. They are required at the antenna so that it points directly at the satellite. Look angles are calculated by considering the elliptical orbit. These angles change in order to track the satellite.

**Azimuth angle:-** The azimuth angle is an angle measured from North direction in the local horizontal plane.

**Elevation angle:-** The elevation angle is the angle measured perpendicular to the horizontal plane (in the vertical plane) to the line-of-sight to the satellite.

The three pieces of information that are needed to determine the look angles for the geostationary orbit are

1. The earth-station latitude, denoted here by  $\lambda_E$
2. The earth-station longitude, denoted here by  $\phi_E$
3. The longitude of the subsatellite point, denoted here by  $\phi_{SS}$  (this is just referred to as the satellite longitude)

4. ES: Position of Earth Station
5. SS: Sub-Satellite Point
6. S: Satellite
7.  $d$ : Range from ES to S
8.  $\sigma$ : angle to be determined

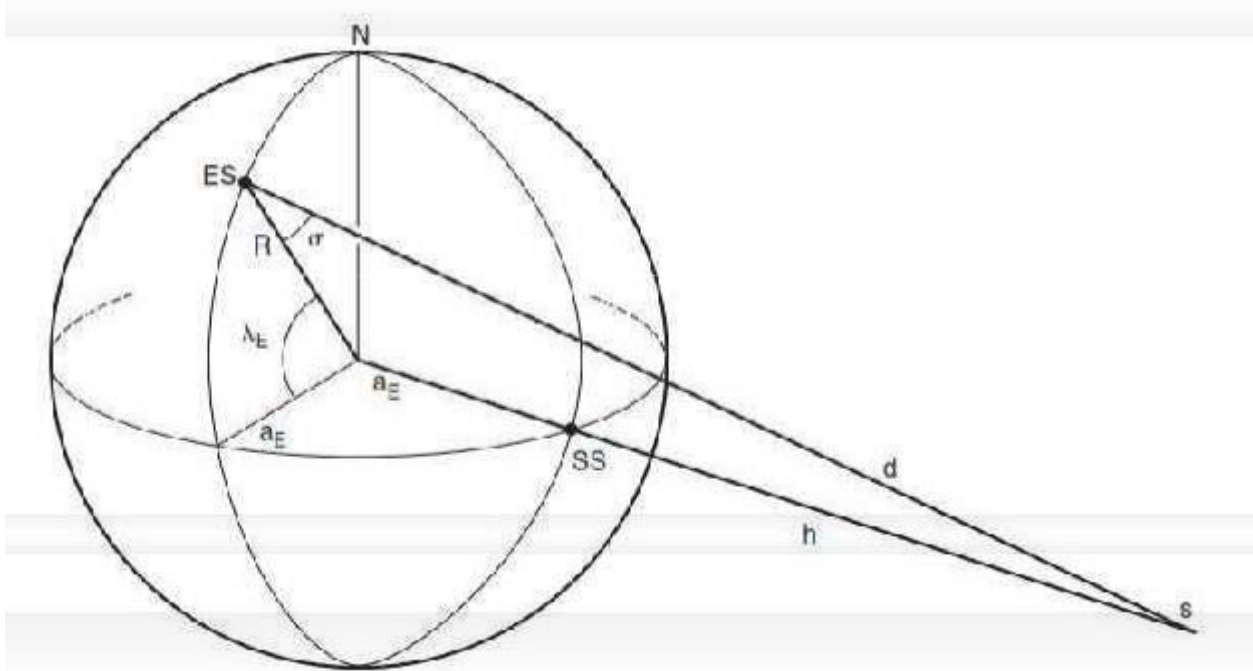

**Fig. 2.4:-** The geometry used in determining the look angles for a geostationary satellite.

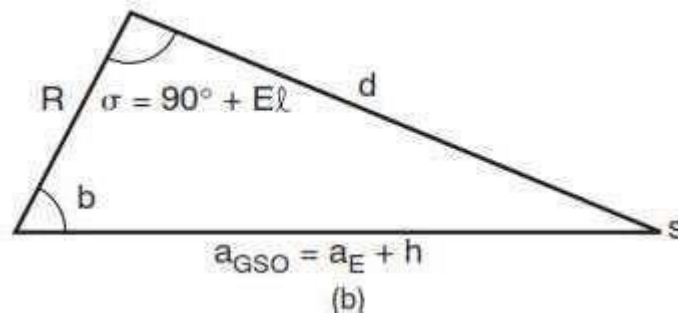
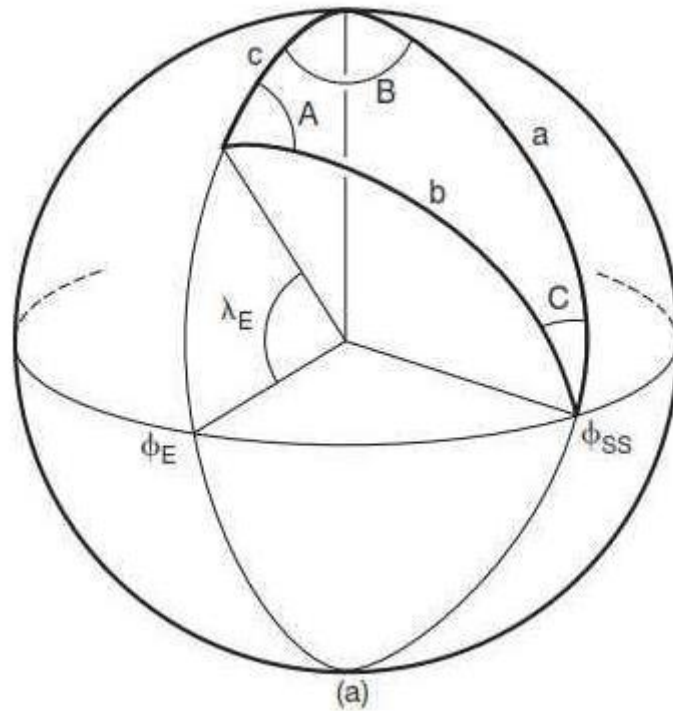

**Figure 4.5** (a) The spherical geometry related to Fig. 4.4. (b) The plane triangle obtained from Fig. 4.4.

There are six angles in all defining the spherical triangle. The three angles  $A$ ,  $B$ , and  $C$  are the angles between the planes. Angle  $A$  is the angle between the plane containing  $c$  and the plane containing  $b$ . Angle  $B$  is the angle between the plane containing  $c$  and the plane containing  $a$ .

Considering figure 5 (b), it's a spherical triangle. All sides are the arcs of a great circle. Three sides of this triangle are defined by the angles subtended by the centre of the earth.

Side  $a$ : angle between North Pole and radius of the sub-satellite point.

Side b: angle between radius of Earth and radius of the sub-satellite point.

Side c: angle between radius of Earth and the North Pole.

$a = 90^\circ$  and such a spherical triangle is called quadrantal triangle.  $c = 90^\circ - \lambda$

Angle B is the angle between the plane containing c and the plane containing a.

$$\text{Thus, } B = \phi_E - \phi_{SS}$$

Angle A is the angle between the plane containing b and the plane containing c.

Angle C is the angle between the plane containing a and the plane containing b.

Thus,

$$a = 90^\circ$$

$$c = 90^\circ - \lambda_E$$

$$B = \phi_E - \phi_{SS}$$

Thus,  $b = \arccos(\cos B \cos \lambda_E)$

$$A = \arcsin(\sin |B| / \sin b)$$

## 2.5 Orbital Perturbation

The *keplerian orbit* described so far is ideal in the sense that it assumes that the earth is a uniform spherical mass and that the only force acting is the centrifugal force resulting from satellite motion balancing the gravitational pull of the earth. In practice, other forces which can be significant are the gravitational forces of the sun and the moon and atmospheric drag. The gravitational pulls of sun and moon have negligible effect on low-orbiting satellites, but they do affect satellites in the geostationary orbit.

There are two types of perturbation:-

- 1- **Gravitational:- when considering third body interaction and the non-spherical shape of the earth.**

The earth is very far away from perfectly spherical. This depends on the earth rotation, earth gravitational potential.

**2- Non-gravitational:- like Atmospheric drag, solar radiation pressure and tidal friction.**

For near-earth satellites, below about 1000 km, the effects of atmospheric drag are significant. Because the drag is greatest at the perigee, the drag acts to reduce the velocity at this point, with the result that the satellite does not reach the same apogee height on successive revolutions.

## CHAPTER: 3 SATELLITES

### 3.1 Satellite Launching

A satellite is sent into space on top of a rocket. When a satellite is put into space, we say that it is “launched.” The rocket that is used to launch a satellite is called a “launch vehicle.” This satellite launching needs the earth stations in order to operate the satellite operation. The satellite launching can be divided into four stages.

- 1- **First Stage:-** The first stage of the launch vehicle contains the rockets and fuel that are needed to lift the satellite and launch vehicle off the ground and into the sky.
  
- 2- **Second Stage:-** The second stage contains smaller rockets that ignite after the first stage is finished. The rockets of the second stage have their own fuel tanks. The second stage is used to send the satellite into space.
  
- 3- **Third Stage (Upper Stage):-** The upper stage of the launch vehicle is connected to the satellite itself, which is enclosed in a metal shield, called a “fairing.” The fairing protects the satellite while it is being launched and makes it easier for the launch vehicle to travel through the resistance of the Earth's atmosphere.
  
- 4- **Fourth Stage (Firing):-** Once the launch vehicle is out of the Earth's atmosphere, the satellite separates from the upper stage. The satellite is then sent into a “transfer orbit” that sends the satellite higher into space. Once the satellite reaches its desired orbital height, it unfurls its solar panels and communication antennas, which had been stored away during the flight. The satellite then takes its place in orbit with other satellites and is ready to provide communications to the public.

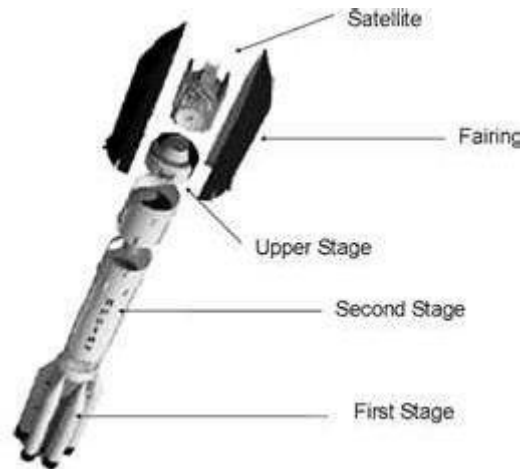

**Figure 3.1** Steps of Satellite Launching

The launch process can be divided into two phases: the launch phase and the orbit injection phase.

#### **1- The Launch Phase**

The launch vehicle places the satellite into the transfer orbit. An elliptical orbit that has at its farthest point from earth (apogee) the geosynchronous elevation of 22,238 miles and at its nearest point (perigee) an elevation of usually not less than 100 miles.

#### **2- The Orbit Injection Phase**

The energy required to move the satellite from the elliptical transfer orbit into the geosynchronous orbit is supplied by the satellite's apogee kick motor (AKM). This is known as the orbit injection phase.

### **3.2 Earth Station**

The earth segment of a satellite communications system consists of the transmit and receive earth stations. The station's antenna functions in both, the transmit and receive modes, but at different frequencies.

An earth station is generally made up of a multiplexor, a modem, up and downconverters, a high power amplifier (HPA) and a low noiseamplifier (LNA). Almost all transmission to satellites is digital, and the digital data streams are combined in a multiplexor and fed to a modem that modulates a carrier frequency in the 50 to 180 MHz range. An upconverter bumps the carrier into the gigahertz range, which goes to the HPA and antenna.

For receiving, the LNA boosts the signals to the downconverter, which lowers the frequency and sends it to the modem. The modem demodulates the carrier, and the digital output goes to

the demultiplexing device and then to its destinations. See earth station on board vessel and base station. A detailed block diagram is shown in fig. 3.2.

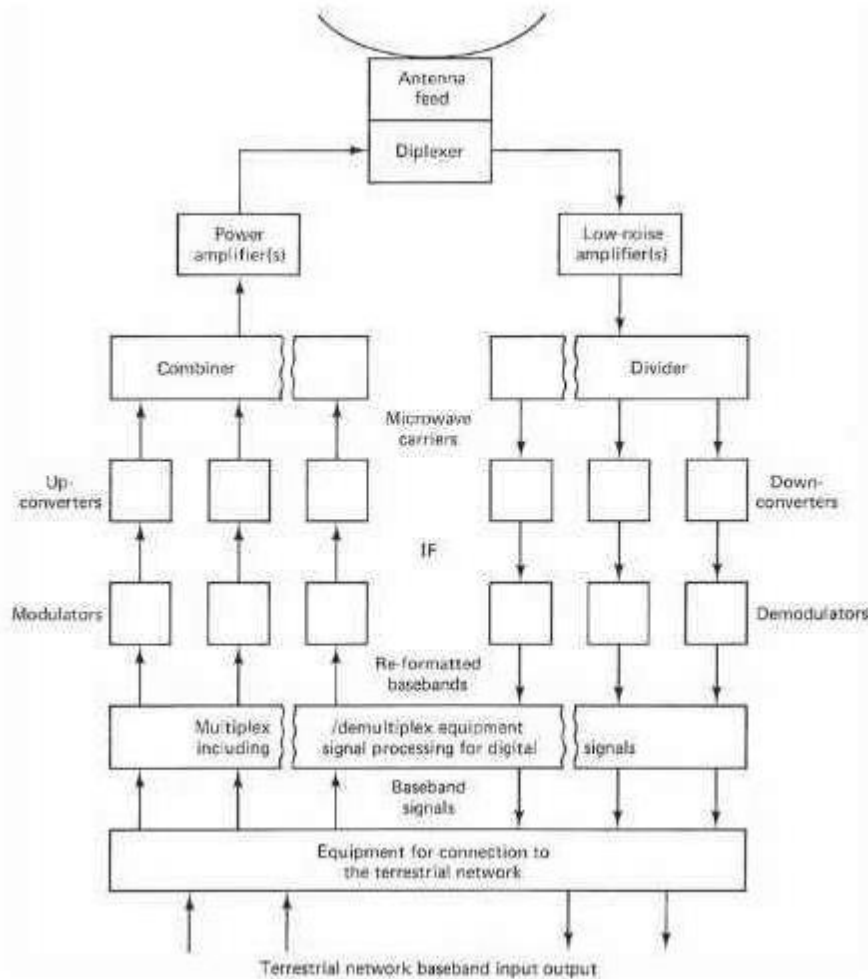

and dish.

**Figure 3.2:-** Block diagram of a transmit-receive earth station

### 3.3 Satellite Sub-systems

A satellite communications system can be broadly divided into two segments—a ground segment and a space segment. The space segment will obviously include the satellites, but it also includes the ground facilities needed to keep the satellites operational, these being referred to as the *tracking, telemetry, and command* (TT&C) facilities. In many networks it is common practice to employ a ground station solely for the purpose of TT&C.

In a communications satellite, the equipment which provides the connecting link between the satellite's transmit and receive antennas is referred to as the *transponder*. The transponder forms one of the main sections of the payload, the other being the antenna subsystems.

**PAYLOAD:-** The payload comprises of a Repeater and Antenna subsystem and performs the primary function of communication.

- 1- REPEATER:-** It is a device that receives a signal and retransmits it to a higher level and/or higher power onto the other side of the obstruction so that the signal can cover longer distance.
- 2- Transparent Repeater:-** It only translates the uplink frequency to an appropriate downlink frequency. It does so without processing the baseband signal. The main element of a typical transparent repeater is a single beam satellite. Signals from antenna and the feed system are fed into the low-noise amplifier through a bandpass filter.
- 3- Regenerative Repeater :-** A repeater, designed for digital transmission, in which digital signals are amplified, reshaped, retimed, and retransmitted. Regenerative Repeater can also be called as a device which regenerates incoming digital signals and then retransmits these signals on an outgoing circuit.
- 4- Antennas :-** The function of an antenna of a space craft is to receive signals and transmit signals to the ground stations located within the coverage area of the satellite. The choice of the antenna system is therefore governed by the size and shape of the coverage area. Consequently, there is also a limit to the minimum size of the antenna footprint.

### **3.4 Satellite System Link Models**

System Link Budget calculations basically relate two quantities, the transmit power and the receive power, and show in detail how the difference between these two powers is accounted for. Link-power budget calculations also need the additional losses and noise factor which is incorporated with the transmitted and the received signals. Along with losses, this unit also discusses the system noise parameters. Various components of the system add to the noise in the signal that has to be transmitted.

### 3.4.1 EQUIVALENT ISOTROPIC RADIATED POWER

The key parameter in link-power budget calculations is the equivalent isotropic radiated power factor, commonly denoted as EIRP. It is the amount of power that a theoretical isotropic antenna (which evenly distributes power in all directions) would emit to produce the peak power density observed in the direction of maximum antenna gain. EIRP can be defined as the power input to one end of the transmission link and the problem to find the power received at the other end.

$$EIRP = G P_s$$

Where,

G - Gain of the Transmitting antenna and G is in decibels.

P<sub>s</sub>- Power of the sender (transmitter) and is calculated in watts.

$$[EIRP] = [G] + [P_s] \text{ dBW}$$

### 3.4.2 TRANSMISSION LOSSES:-

As EIRP is thought of as power input of one end to the power received at the other, the problem here is to find the power which is received at the other end. Some losses that occur in the transmitting – receiving process are constant and their values can be pre – determined.

#### 3.4.2.1 Free-Space Transmission Losses (FSL)

This loss is due to the spreading of the signal in space. Going back to the power flux density equation

$$\psi_m = P_s / 4\pi r^2$$

The power that is delivered to a matched receiver is the power flux density. It is multiplied by the effective aperture of the receiving antenna. Hence, the received power is:

$$\begin{aligned} P_R &= \psi_m A_{eff} \\ &= \frac{EIRP \cdot \lambda^2 G_R}{4\pi r^2} \end{aligned}$$

Where

r- distance between transmitter and receiver,  $G_R$  - power gain at the receiver

In decibels, the above equation becomes:

$$[P_R] = [EIRP] + [G_R] - 10 \log \left( \frac{4\pi r}{\lambda} \right)^2$$

$$[FSL] = 10 \log \left( \frac{4\pi r}{\lambda} \right)^2$$

$$[P_R] = [EIRP] + [G_R] - [FSL]$$

**3.4.2.2 Feeder Losses (RFL):-** This loss is due to the connection between the satellite receiver device and the receiver antenna is improper. Losses here occur is connecting wave guides, filers and couplers. The receiver feeder loss values are added to free space loss.

**3.4.2.1 Antenna Misalignment Losses (AML):-** To attain a good communication link, the earth station's antenna and the communicating satellite's antenna must face each other in such a way that the maximum gain is attained.

**3.4.2.1 Fixed Atmospheric (AA) and Ionospheric losses (PL):-**The gases present in the atmosphere absorb the signals. This kind of loss is usually of a fraction of decibel in quantity. Along with the absorption losses, the ionosphere introduces a good amount of depolarization of signal which results in loss of signal.

### 3.5 Link Equations

The EIRP can be considered as the input power to a transmission link. Due to the above discussed losses, the power at the receiver that is the output can be considered as a simple calculation of EIRP– losses.

Losses = [FSL] + [RFL] + [AML] + [AA] + [PL]  
The received power that is P

$$[P_R] = [EIRP] + [G_R] - [Losses]$$

Where;

[ $P_R$ ] - Received power in dB, [EIRP] - equivalent isotropic radiated power in dBW.

[ $G_R$ ] - Isotropic power gain at the receiver and its value is in dB.

[FSL]-Free-space transmission loss in dB.

[RFL] -Receiver feeder loss in dB.

[AA] -Atmospheric absorption loss in dB.

[AML] -Antenna misalignment loss in dB.

[PL] - Depolarization loss in dB.

## CHAPTER 4: MODULATION AND MULTIPLEXING TECHNIQUES

### 4.1 Multiple Access

Multiple accesses is defined as the technique where in more than one pair of earth stations can simultaneously use a satellite transponder. A multiple access scheme is a method used to distinguish among different simultaneous transmissions in a cell. A radio resource can be a different time interval, a frequency interval or a code with a suitable power level.

If the different transmissions are differentiated for the frequency band, it will be defined as the Frequency Division Multiple Access (FDMA). Whereas, if transmissions are distinguished on the basis of time, then it is considered as Time Division Multiple Access (TDMA). If a different code is adopted to separate simultaneous transmissions, it will be Code Division Multiple Access (CDMA).

#### 4.1.1 Frequency Division Multiple Access (FDMA)

Frequency Division Multiple Access or FDMA is a channel access method used in multiple-access protocols as a channelization protocol. FDMA gives users an individual allocation of one or several frequency bands, or channels. It is particularly commonplace in satellite communication.

- In FDMA all users share the satellite transponder or frequency channel simultaneously but each user transmits at single frequency.
- FDMA can be used with both analog and digital signal.
- FDMA requires high-performing filters in the radio hardware.
- FDMA is not vulnerable to the timing problems that TDMA has. Since a predetermined frequency band is available for the entire period of communication, stream data (a continuous flow of data that may not be packetized) can easily be used with FDMA.
- Each user transmits and receives at different frequencies as each user gets a unique frequency slots.

### 4.1.2 Time Division Multiple Access (TDMA)

**Time division multiple access (TDMA)** is a channel access method for shared medium networks. It allows several users to share the same frequency channel by dividing the signal into different time slots. This allows multiple stations to share the same transmission medium (e.g. radio frequency channel) while using only a part of its channel capacity.

- Shares single carrier frequency with multiple users.
- Slots can be assigned on demand in dynamic TDMA.
- Less stringent power control than CDMA due to reduced intra cell interference
- Higher synchronization overhead than CDMA
- Cell breathing (borrowing resources from adjacent cells) is more complicated than in CDMA.
- Frequency/slot allocation complexity.

### 4.1.3 Code Division Multiple Access (CDMA)

**Code division multiple access (CDMA)** is a channel access method used by various radio communication technologies. CDMA is an example of multiple access, which is where several transmitters can send information simultaneously over a single communication channel. This allows several users to share a band of frequencies (see bandwidth). CDMA is used as the access method in many mobile phone standards such as cdmaOne, CDMA2000 (the 3G evolution of cdmaOne), and WCDMA (the 3G standard used by GSM carriers), which are often referred to as simply *CDMA*.

- One of the early applications for code division multiplexing is in the Global Positioning System (GPS). This predates and is distinct from its use in mobile phones.
- The Qualcomm standard IS-95, marketed as cdmaOne.
- The Qualcomm standard IS-2000, known as CDMA2000, is used by several mobile phone companies, including the Globalstar satellite phone network.
- The UMTS 3G mobile phone standard, which uses W-CDMA.
- CDMA has been used in the Omni TRACS satellite system for transportation logistics.

## 4.2 Direct Broadcast Satellite Services

**Direct-broadcast satellite** (DBS) is a type of artificial satellite which usually sends satellite television signals for home reception through geostationary satellites. The type of satellite television which uses direct-broadcast satellites is known as direct-broadcast satellite television (DBSTV) or direct-to-home television (DTHTV). This has initially distinguished the transmissions directly intended for home viewers from cable television distribution services that are sometimes carried on the same satellite.

A DBS subscriber installation consists of a dish antenna two to three feet (60 to 90 centimeters) in diameter, a conventional TV set, a signal converter placed next to the TV set, and a length of coaxial cable between the dish and the converter. The dish intercepts microwave signals directly from the satellite. The converter produces output that can be viewed on the TV receiver. Broadcast services include audio, television, and Internet services. Direct broadcast television, which is digital TV, is the subject of this chapter. A Typical DBS system block diagram is shown in fig. 4.1. The home receiver consists of two units—an outdoor unit and an indoor unit.

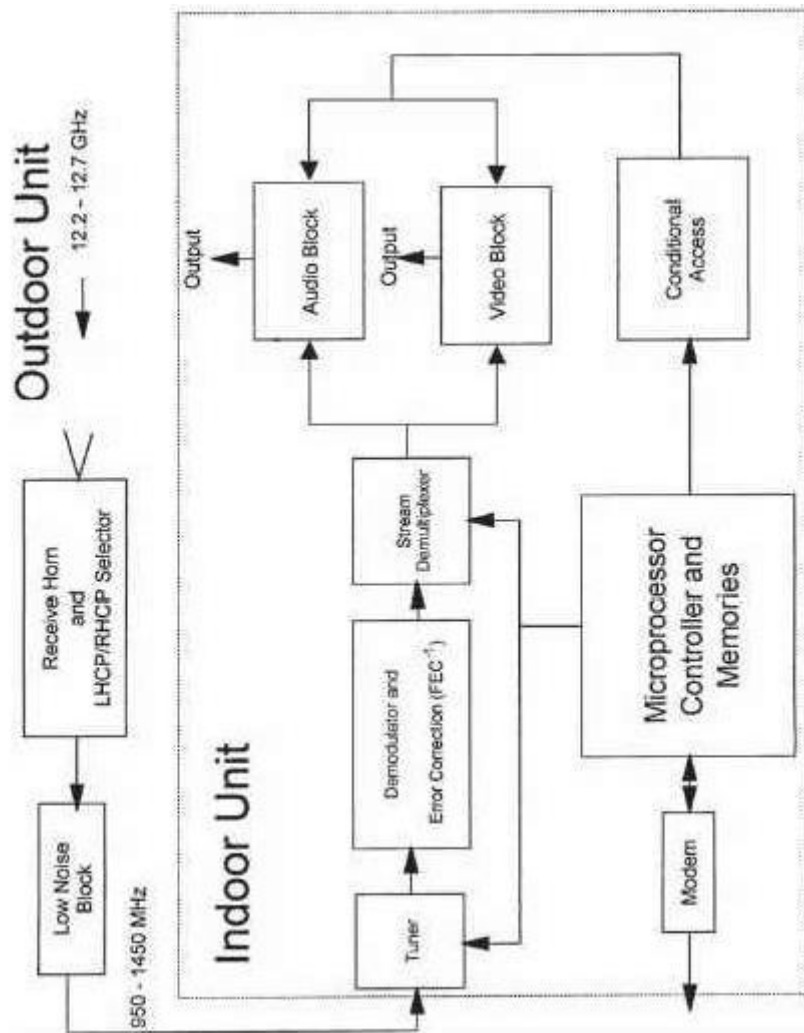

**Fig. 4.1** Block schematic for the outdoor unit (ODU) and IDU unit of DBS.

**The Home Receiver Outdoor Unit (ODU):-** The downlink signal, covering the frequency range 12.2 to 12.7 GHz, is focused by the antenna into the receive horn. The horn feeds into a polarizer that can be switched to pass either left-hand circular or right-hand circular polarized signals. The low-noise block that follows the polarizer contains a *low-noise amplifier* (LNA) and a down converter. The down converter converts the 12.2- to 12.7-GHz band to 950 to 1450 MHz, a frequency range better suited to transmission through the connecting cable to the indoor unit.

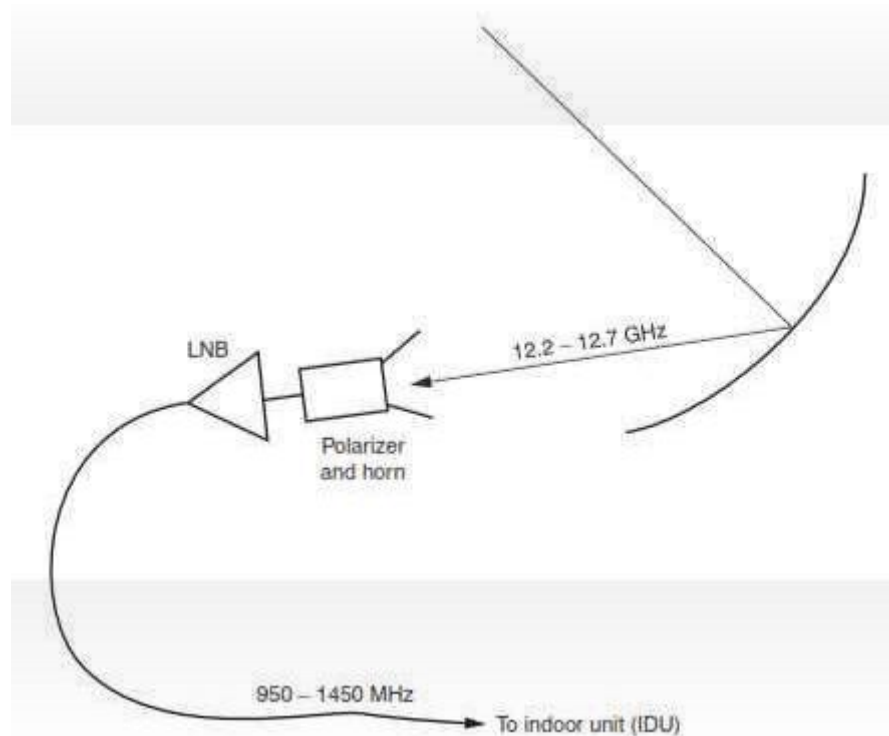

**Fig. 4.2** Block schematic for the outdoor unit (ODU)

**The Home Receiver Indoor Unit (IDU):-** The transponder frequency bands shown in Fig. 16.2 are down converted to be in the range 950 to 1450 MHz, but of course, each transponder retains its 24-MHz bandwidth. The IDU must be able to receive any of the 32 transponders, although only 16 of these will be available for a single polarization. The tuner selects the desired transponder. It should be recalled that the carrier at the center frequency of the transponder is QPSK modulated by the bit stream, which itself may consist of four to eight TV programs TDM. Following the tuner, the carrier is demodulated, the QPSK modulation being converted to a bit stream. Error correction is carried out in the decoder block labeled FEC.

### 4.3 Application of LEO

The evolution from geo-stationary to low-Earthorbit (LEO) satellites has resulted in a number of proposed global satellite systems, which can be grouped into three distinct types - Little LEOs, Big LEOs, and Broadband LEOs. These systems can best be distinguished by reference to their terrestrial counterparts: paging, cellular, and fiber, as shown in Table 4.1. On the ground, paging, cellular, and fiber services are complementary, not competitive, because they offer fundamentally different kinds of services. Similarly, the Little LEOs, Big LEOs, and Broadband

LEOs are complementary rather than competitive because they are providing distinctly different services targeted at different markets, and have different pricing structures.

**Table 4.1 Terrestrial Counterparts**

	<b>Little LEO</b>	<b>Big LEO</b>	<b>Broadband LEO</b>
<b>Example Systems</b>	ORBCOMM Starsys	IRIDIUM Globalstar ICO	Teledesic
<b>Terrestrial Counterpart</b>	Paging	Cellular	Fiber

Typical applications of the various types of LEO systems are shown in Table 2. Of course the Big LEOs can support the Little LEO applications, and the Broadband LEOs can support both the Big and Little LEO applications.

**Table 4.2 Application of LEO Satellites**

Little LEOs	Paging E-mail Fax
Big LEOs	Voice Telephone Low Speed Data
Broadband LEOs	Multimedia Conferencing Internet Access Video Conferencing Video-Telephony High Speed Data

## 4.4 MEO and GEO Satellites

**Medium Earth orbit (MEO)**, sometimes called **intermediate circular orbit (ICO)**, is the region of space around the Earth above low Earth orbit (altitude of 2,000 kilometres (1,243 mi)) and below geostationary orbit (altitude of 35,786 kilometres (22,236 mi)). The most common use for satellites in this region is for navigation, communication, and geodetic/space environment science.<sup>[1]</sup> The most common altitude is approximately 20,200 kilometres (12,552 mi), which yields an orbital period of 12 hours, as used, for example, by the Global Positioning System (GPS). Other satellites in Medium Earth Orbit include Glonass (with an altitude of 19,100 kilometres (11,868 mi)) and Galileo (with an altitude of 23,222 kilometres (14,429 mi)) constellations.<sup>[citation needed]</sup> Communications satellites that cover the North and South Pole are also put in MEO.

Geostationary satellites appear to be fixed over one spot above the equator. Receiving and transmitting antennas on the earth do not need to track such a satellite. These antennas can be fixed in place and are much less expensive than tracking antennas. These satellites have revolutionized global communications, television broadcasting and weather forecasting, and have a number of important defense and intelligence applications.

One disadvantage of geostationary satellites is a result of their high altitude: radio signals take approximately 0.25 of a second to reach and return from the satellite, resulting in a small but significant signal delay. This delay increases the difficulty of telephone conversation and reduces the performance of common network protocols such as TCP/IP, but does not present a problem with non-interactive systems such as television broadcasts. There are a number of proprietary satellite data protocols that are designed to proxy TCP/IP connections over long-delay satellite links—these are marketed as being a partial solution to the poor performance of native TCP over satellite links. TCP presumes that all loss is due to congestion, not errors, and probes link capacity with its "slow-start" algorithm, which only sends packets once it is known that earlier packets have been received. Slow start is very slow over a path using a geostationary satellite. There are approximately 600 geosynchronous satellites, some of which are not operational

**Table 4.3 Application of MEO and GEO Satellites**

<b>Satellites</b>	<b>Application</b>
Medium Earth Orbit	High-speed telephone signals
Geosynchronous Orbit	Satellite Television
Geostationary Orbit	Direct broadcast television

**References**

- 1- <http://www.williamcraigcook.com/satellite/index.html>
- 2- [http://transition.fcc.gov/cgb/kidszone/satellite/kidz/into\\_space.html](http://transition.fcc.gov/cgb/kidszone/satellite/kidz/into_space.html)
- 3- Satellite Communications Dennis Roddy 3rd edition, McGraw Hill publication.
- 4- <http://www.radio-electronics.com/info/satellite/satellite-orbits/satellites-orbit-definitions.php>.
- 5- [www.wikipedia.com](http://www.wikipedia.com)
- 6- LEOs - THE COMMUNICATIONS SATELLITES of 21Century by Mark A. Sturza

# OPTICAL FIBRE SYSTEM

An **optical fiber** (or **optical fibre**) is a flexible, transparent fiber made of extruded glass (silica) or plastic, slightly thicker than a human hair. It can function as a waveguide, or “light pipe”, to transmit light between the two ends of the fiber. The field of applied science and engineering concerned with the design and application of optical fibers is known as **fiber optics**.

Optical fibers are widely used in fiber-optic communications, where they permit transmission over longer distances and at higher bandwidths (data rates) than wire cables. Fibers are used instead of metal wires because signals travel along them with less loss and are also immune to electromagnetic interference. Fibers are also used for illumination, and are wrapped in bundles so that they may be used to carry images, thus allowing viewing in confined spaces. Specially designed fibers are used for a variety of other applications, including sensors and fiber lasers.

Optical fibers typically include a transparent core surrounded by a transparent cladding material with a lower index of refraction. Light is kept in the core by total internal reflection. This causes the fiber to act as a waveguide. Fibers that support many propagation paths or transverse modes are called multi-mode fibers (MMF), while those that only support a single mode are called single-mode fibers (SMF). Multi-mode fibers generally have a wider core diameter, and are used for short-distance communication links and for applications where high power must be transmitted. Single-mode fibers are used for most communication links longer than 1,000 meters (3,300 ft).

## **How a Fiber Optic Communication Works?**

Unlike copper wire based transmission where the transmission entirely depends on electrical signals passing through the cable, the fiber optics transmission involves transmission of signals in the form of light from one point to the other. Furthermore, a fiber optic communication network consists of transmitting and receiving circuitry, a light source and detector devices like the ones shown in the figure.

When the input data, in the form of electrical signals, is given to the transmitter circuitry, it converts them into light signal with the help of a light source. This source is of LED whose amplitude, frequency and phases must remain stable and free from fluctuation in order to have efficient transmission. The light beam from the source is carried by a fiber optic cable to the destination circuitry wherein the information is transmitted back to the electrical signal by a receiver circuit.

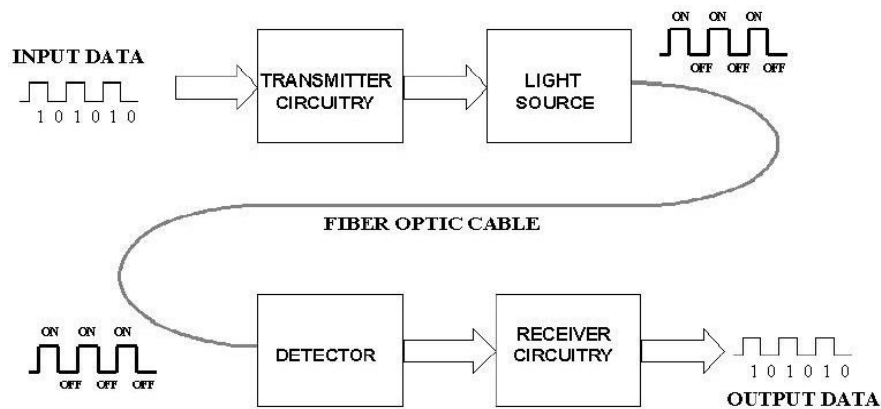

The Receiver circuit consists of a photo detector along with an appropriate electronic circuit, which is capable of measuring magnitude, frequency and phase of the optic field. This type of communication uses the wave lengths near to the [infrared band](#) that are just above the visible range. Both LED and Laser can be used as light sources based on the application.

### 3 Basic Elements of a Fiber Optic Communication System

There are three main basic elements of fiber optic communication system. They are

1. Compact Light Source
2. Low loss Optical Fiber
3. Photo Detector

Accessories like connectors, switches, couplers, multiplexing devices, amplifiers and splices are also essential elements in this communication system.

#### 1. Compact Light Source

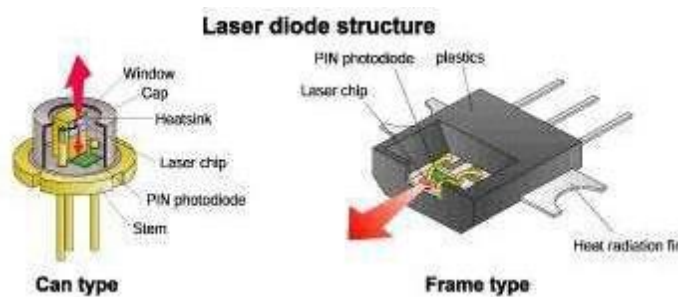

#### Laser Diodes

Depending on the applications like local area networks and the long haul communication systems, the light source requirements vary. The requirements of the sources include power, speed, spectral line width, noise, ruggedness, cost, temperature, and so on. Two components are used as light sources: [light emitting diodes](#) (LED's) and laser diodes.

The light emitting diodes are used for short distances and low data rate applications due to their low bandwidth and power capabilities. Two such LEDs structures include Surface and Edge Emitting Systems. The surface emitting diodes are simple in design and are reliable, but due to its broader line width and modulation frequency limitation edge emitting diode are mostly used. Edge emitting diodes have high power and narrower line width capabilities.

For longer distances and high data rate transmission, Laser Diodes are preferred due to its high power, high speed and narrower spectral line width characteristics. But these are inherently non-linear and more sensitive to temperature variations.

**LED Versus Laser**

Characteristic	LED	Laser
Output power	Lower	Higher
Spectral width	Wider	Narrower
Numerical aperture	Larger	Smaller
Speed	Slower	Faster
Cost	Less	More
Ease of operation	Easier	More difficult

## LED vs Laser Diodes

Nowadays many improvements and advancements have made these sources more reliable. A few of such comparisons of these two sources are given below. Both these sources are modulated using either direct or external modulation techniques.

## 2. Low Loss Optical Fiber

Optical fiber is a cable, which is also known as cylindrical dielectric waveguide made of low loss material. An optical fiber also considers the parameters like the environment in which it is operating, the tensile strength, durability and rigidity. The Fiber optic cable is made of high quality extruded glass (si) or plastic, and it is flexible. The diameter of the fiber optic cable is in between 0.25 to 0.5mm (slightly thicker than a human hair).

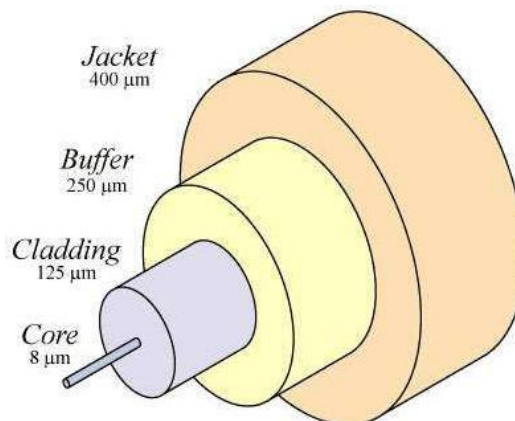

A Fiber Optic Cable consists of four parts.

- Core
- Cladding
- Buffer
- Jacket

### **Core**

The core of a fiber cable is a cylinder of plastic that runs all along the fiber cable's length, and offers protection by cladding. The diameter of the core depends on the application used. Due to internal reflection, the light travelling within the core reflects from the core, the cladding boundary. The core cross section needs to be a circular one for most of the applications.

### **Cladding**

Cladding is an outer optical material that protects the core. The main function of the cladding is that it reflects the light back into the core. When light enters through the core (dense material) into the cladding (less dense material), it changes its angle, and then reflects back to the core.

### **Buffer**

The main function of the buffer is to protect the fiber from damage and thousands of optical fibers arranged in hundreds of optical cables. These bundles are protected by the cable's outer covering that is called jacket.

### **JACKET**

Fiber optic cable's jackets are available in different colors that can easily make us recognize the exact color of the cable we are dealing with. The color yellow clearly signifies a single mode cable, and orange color indicates multimode.

### ***2 Types of Optical Fibers***

**Single-Mode Fibers:** Single mode fibers are used to transmit one signal per fiber; these fibers are used in telephone and television sets. Single mode fibers have small cores.

**Multi-Mode Fibers:** Multimode fibers are used to transmit many signals per fiber; these signals are used in computer and local area networks that have larger cores.

### 3. Photo Detectors

The purpose of photo detectors is to convert the light signal back to an electrical signal. Two types of photo detectors are mainly used for optical receiver in optical communication system: PN photo diode and avalanche photo diode. Depending on the application's wavelengths, the material composition of these devices vary. These materials include silicon, germanium, InGaAs, etc.

## Basic optical laws

### Refraction of light

As a light ray passes from one transparent medium to another, it changes direction; this phenomenon is called refraction of light. How much that light ray changes its direction depends on the refractive index of the mediums.

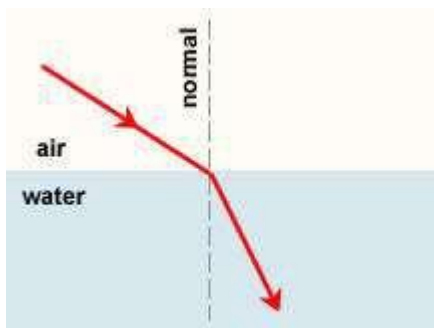

### Refractive Index

Refractive index is the speed of light in a vacuum (abbreviated **c**,  $c=299,792.458\text{km/second}$ ) divided by the speed of light in a material (abbreviated **v**). Refractive index measures how much a material refracts light. Refractive index of a material, abbreviated as **n**, is defined as

$$n=c/v$$

## Snell's Law

In 1621, a Dutch physicist named Willebrord Snell derived the relationship between the different angles of light as it passes from one transparent medium to another. When light passes from one transparent material to another, it bends according to Snell's law which is defined as:

$$n_1 \sin(\theta_1) = n_2 \sin(\theta_2)$$

where:

$n_1$  is the refractive index of the medium the light is leaving

$\theta_1$  is the incident angle between the light beam and the normal (normal is  $90^\circ$  to the interface between two materials)

$n_2$  is the refractive index of the material the light is entering

$\theta_2$  is the refractive angle between the light ray and the normal

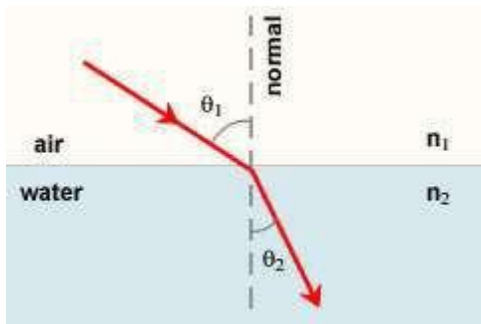

### Note:

For the case of  $\theta_1 = 0^\circ$  (i.e., a ray perpendicular to the interface) the solution is  $\theta_2 = 0^\circ$  regardless of the values of  $n_1$  and  $n_2$ . That means a ray entering a medium perpendicular to the surface is never bent.

The above is also valid for light going from a dense (higher  $n$ ) to a less dense (lower  $n$ ) material; the symmetry of Snell's law shows that the same ray paths are applicable in opposite direction.

---

## Total Internal Reflection

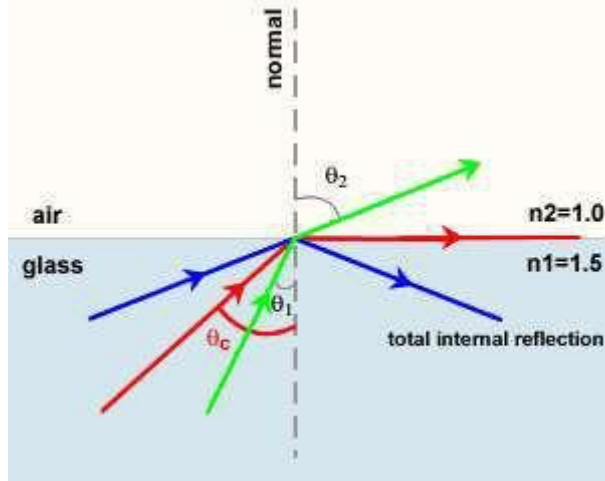

When a light ray crosses an interface into a medium with a higher refractive index, it bends towards the normal. Conversely, light traveling across an interface from a higher refractive index medium to a lower refractive index medium will bend away from the normal.

This has an interesting implication: at some angle, known as the **critical angle**  $\theta_c$ , light traveling from a higher refractive index medium to a lower refractive index medium will be refracted at  $90^\circ$ ; in other words, refracted along the interface.

If the light hits the interface at any angle larger than this critical angle, it will not pass through to the second medium at all. Instead, all of it will be reflected back into the first medium, a process known as **total internal reflection**.

The critical angle can be calculated from Snell's law, putting in an angle of  $90^\circ$  for the angle of the refracted ray  $\theta_2$ . This gives  $\theta_1$ :

$$\theta_1 = \arcsin\left[\left(\frac{n_2}{n_1}\right) \sin(\theta_2)\right]$$

Since

$$\theta_2 = 90^\circ$$

So

$$\sin(\theta_2) = 1$$

Then

$$\theta_c = \theta_1 = \arcsin\left(\frac{n_2}{n_1}\right)$$

For example, with light trying to emerge from glass with  $n_1=1.5$  into air ( $n_2 =1$ ), the critical angle  $\theta_c$  is  $\arcsin(1/1.5)$ , or  $41.8^\circ$ .

For any angle of incidence larger than the critical angle, Snell's law will not be able to be solved for the angle of refraction, because it will show that the refracted angle has a sine larger than 1, which is not possible. In that case all the light is totally reflected off the interface, obeying the law of reflection.

## Optical Fiber Mode

### What is Fiber Mode?

An optical fiber guides light waves in distinct patterns called *modes*. Mode describes the distribution of light energy across the fiber. The precise patterns depend on the wavelength of light transmitted and on the variation in refractive index that shapes the core. In essence, the variations in refractive index create boundary conditions that shape how light waves travel through the fiber, like the walls of a tunnel affect how sounds echo inside.

We can take a look at large-core step-index fibers. Light rays enter the fiber at a range of angles, and rays at different angles can all stably travel down the length of the fiber as long as they hit the core-cladding interface at an angle larger than critical angle. These rays are different modes.

Fibers that carry more than one mode at a specific light wavelength are called multimode fibers. Some fibers have very small diameter core that they can carry only one mode which travels as a straight line at the center of the core. These fibers are single mode fibers. This is illustrated in the following picture.

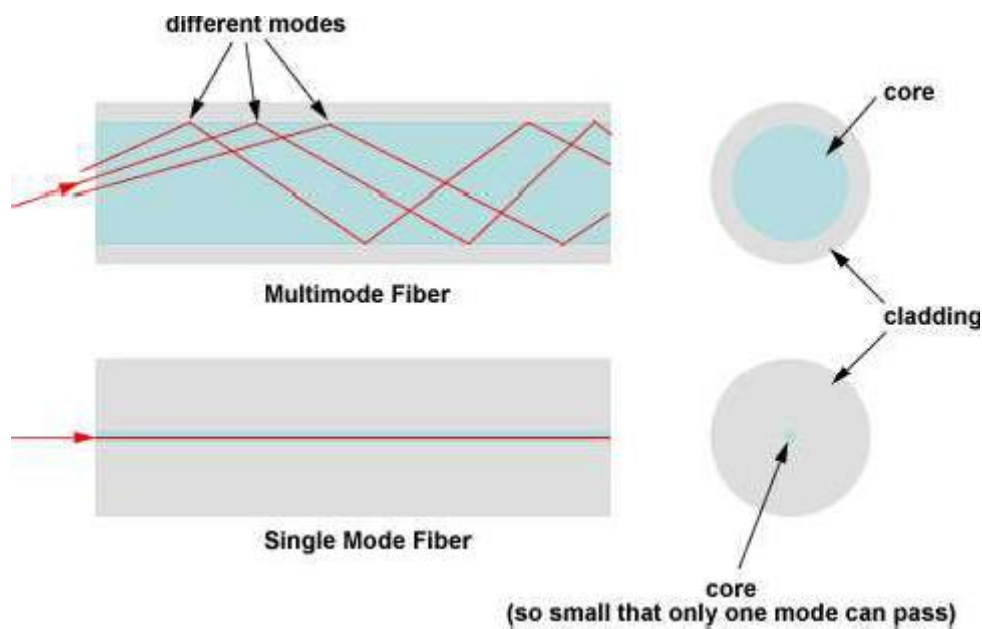

## Optical Fiber Index Profile

Index profile is the refractive index distribution across the core and the cladding of a fiber. Some optical fiber has a step index profile, in which the core has one uniformly distributed index and the cladding has a lower uniformly distributed index. Other optical fiber has a graded index profile, in which refractive index varies gradually as a function of radial distance from the fiber center. Graded-index profiles include power-law index profiles and parabolic index profiles. The following figure shows some common types of index profiles for single mode and multimode fibers.

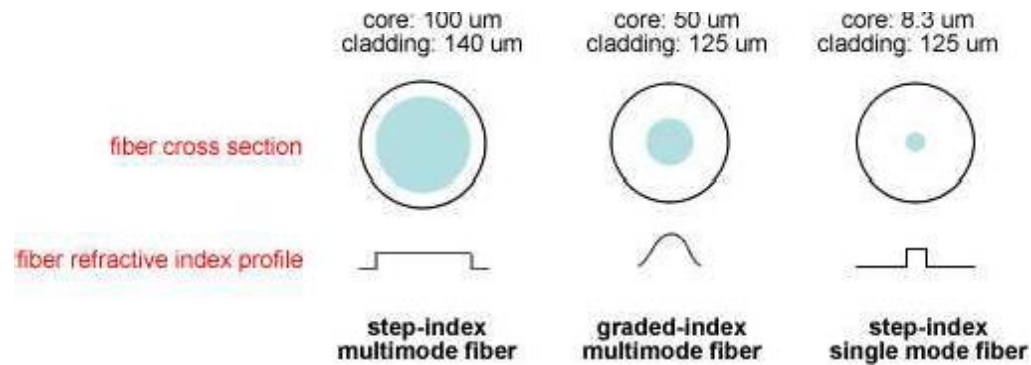

---

## Multimode Fibers

As their name implies, multimode fibers propagate more than one mode. Multimode fibers can propagate over 100 modes. The number of modes propagated depends on the core size and numerical aperture (NA).

As the core size and NA increase, the number of modes increases. Typical values of fiber core size and NA are 50 to 100 micrometer and 0.20 to 0.29, respectively.

## Single Mode Fibers

The core size of single mode fibers is small. The core size (diameter) is typically around 8 to 10 micrometers. A fiber core of this size allows only the fundamental or lowest order mode to propagate around a 1300 nanometer (nm) wavelength. Single mode fibers propagate only one mode, because the core size approaches the operational wavelength. The value of the normalized frequency parameter ( $V$ ) relates core size with mode propagation.

In single mode fibers,  $V$  is less than or equal to 2.405. When  $V = 2.405$ , single mode fibers propagate the fundamental mode down the fiber core, while higher order modes are lost in the cladding. For low  $V$  values ( $<1.0$ ), most of the power is propagated in the cladding material. Power transmitted by the cladding is easily lost at fiber bends. The value of  $V$  should remain near the 2.405 level.

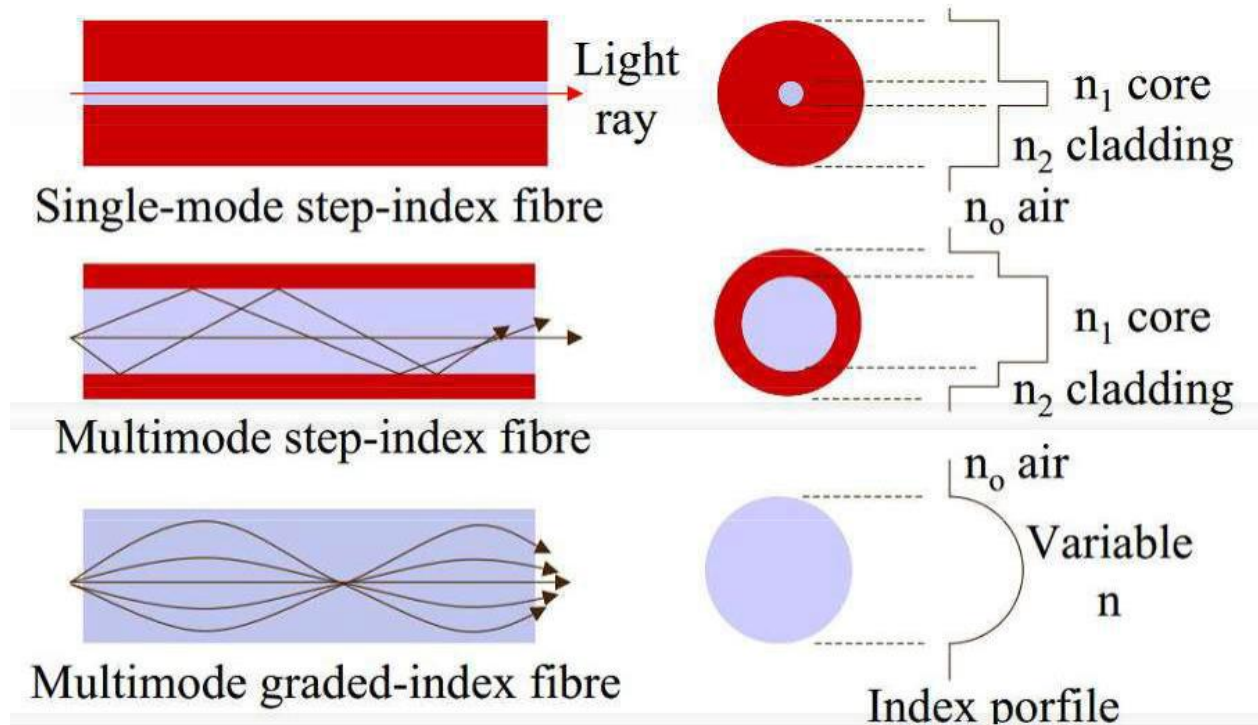

## Multimode Step Index Fiber

Core diameter range from 50-1000  $\mu\text{m}$ . Light propagate in many different ray paths, or modes, hence the name multimode. Index of refraction is same all across the core of the fiber. Bandwidth range 20-30 MHz. Multimode Graded Index Fiber The index of refraction across the core is gradually changed from a maximum at the center to a minimum near the edges, hence the name "Graded Index". Bandwidth ranges from 100MHz-Km to 1GHz-Km

Pulse dispersion in a step index optical fiber is given by

$$\text{pulse dispersion} = \frac{\Delta n_1 \ell}{c}$$

where

$\Delta$  is the difference in refractive indices of core and cladding.

$n_1$  is the refractive index of core

$\ell$  is the length of the optical fiber under observation

$$c = 3 \times 10^8 \text{ ms}^{-1}$$

## Graded-Index Multimode Fiber

Contains a core in which the refractive index diminishes gradually from the center axis out toward the cladding. The higher refractive index at the center makes the light rays moving down the axis advance more slowly than those near the cladding. Due to the graded index, light in the core curves helically rather than zigzag off the cladding, reducing its travel distance. The shortened path and the higher speed allow light at the periphery to arrive at a receiver at about the same time as the slow but straight rays in the core axis. The result: digital pulse suffers less dispersion. This type of fiber is best suited for local-area networks.

Pulse dispersion in a graded index optical fiber is given by

$$\text{Pulse dispersion} = \frac{k\delta n n_1 l}{c},$$

where

$\delta n$  is the difference in refractive indices of core and cladding,

$n_1$  is the refractive index of the cladding,

$l$  is the length of the fiber taken for observing the pulse dispersion,

$c \approx 3 \times 10^8 \text{ m/s}$  is the speed of light, and

$k$  is the constant of graded index profile.

## Fibre Optic Link Budget

The FOL budget provides the design engineer with quantitative performance information about the FOL. It is determined by computing the FOL power budget and overall link gain.

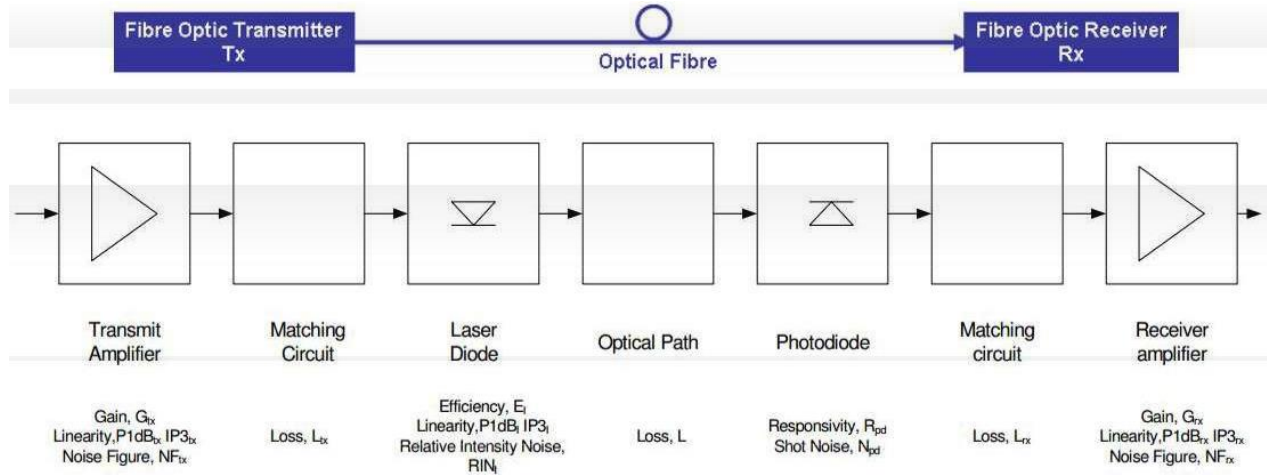

## Fibre Optic Power Budget

The FOL power budget (PB) is simply the difference between the maximum and minimum signals that the FOL can transport.

## Fibre Optic Link Gain

FOL link gain is a summation of gains and losses derived from the different elements of the FOL as shown in above figure. Gains and losses attributed to the Tx, Rx, optical fibre and connectors, as well as any additional in-line components such as splitters, multiplexers, splices etc, must be taken into accounts when computing the linkloss budget.

In the case of a simple point-to-point link described in Above figure, and resistively matched (50 ohms) components,

the link gain (G) is expressed as:-

$$G = T + R - 2LO \quad (1)$$

Where T is the gain of the Tx, R is the gain of the Rx, and LO is the insertion loss attributed to the fibre link. Note the factor of two in this last optical term, meaning that for each dB optical loss there is a corresponding 2dB RF loss.

To calculate LO the following information is needed.

Standard Corning SMF28 single mode fibre has an insertion loss 0.2dB/km at 1310nm and 0.15dB/km at 1550nm. Optical connectors such as FC/APC typically have an insertion loss of 0.25dB. Optical splices introduce a further 0.25dB loss. Refer to TIA 568 standard for Interfacility and Premise cable specifications.

## Output Noise Power

The output noise power of an analogue FOL must also be considered when quantifying the overall link budget. The measured output noise power is defined as:-

$$\text{Output Noise Power} = \text{ONF} + 10\log_{10}(\text{BW})$$

Where ONF (Optical Noise Floor) is the noise output of the link on its own, defined in a bandwidth of 1Hz, and BW is the bandwidth of the service transported over fibre. In a real installation, the NF, or Noise Figure is used to define the noise performance of the fibre optic link and is related to the output noise floor as follows:

$$\text{ONF} = -174\text{dBm} + \text{NF} + G \quad (3)$$

-174dBm, is the noise contribution from an ideal 1ohm resistive load at zero degrees Kelvin.

The measured output noise power is given as:-

$$= -174\text{dBm} + \text{NF} + G + 10\log_{10}(\text{MBW})$$

# ATTENUATION ON OPTICAL FIBER

The signal on optical attenuates due to following mechanisms.

1. Intrinsic loss in the fiber material.
2. Scattering due to micro irregularities inside the fiber.
3. Micro-bending losses due to micro-deformation of the fiber.
4. Bending or radiation losses on the fiber.

The first two losses are intrinsically present in any fiber and the last two depend on the environment in which the fiber is laid.

## Material Loss

**(a) Due to impurities:** The material loss is due to the impurities present in glass used for making fibers. In spite of best purification efforts, there are always impurities like Fe, Ni, Co, Al which are present in the fiber material. The Fig. shows attenuation due to various molecules inside glass as a function of wavelength. It can be noted from the figure that the material loss due to impurities reduces substantially beyond about 1200nm wavelength.

**(b) Due to OH molecule:** In addition, the OH molecule diffuses in the material and causes absorption of light. The OH molecule has main absorption peak somewhere in the deep infra-red wavelength region. However, it shows substantial loss in the range of 1000 to 2000nm.

**(b) Due to infra-red absorption :** Glass intrinsically is a good infra-red absorber. As we increase the wavelength the infra-red loss increases rapidly.

## SCATTERING LOSS

The scattering loss is due to the non-uniformity of the refractive index inside the core of the fiber. The refractive index of an optical fiber has fluctuation of the order of  $10^{-4}$  over spatial scales much smaller than the optical wavelength. These fluctuations act as scattering centres for the light passing through the fiber. The process is, **Rayleigh Scattering**. A very tiny fraction of light gets scattered and therefore contributes to the loss.

The Rayleigh scattering is a very strong function of the wavelength. The scattering loss varies as  $\lambda^{-4}$ . This loss therefore rapidly reduces as the wavelength increases. For each doubling of the wavelength, the scattering loss reduces by a factor of 16. It is then clear that the scattering loss at 1550nm is about factor of 16 lower than that at 800nm.

The following Fig. shows the infrared, scattering and the total loss as a function of wavelength.

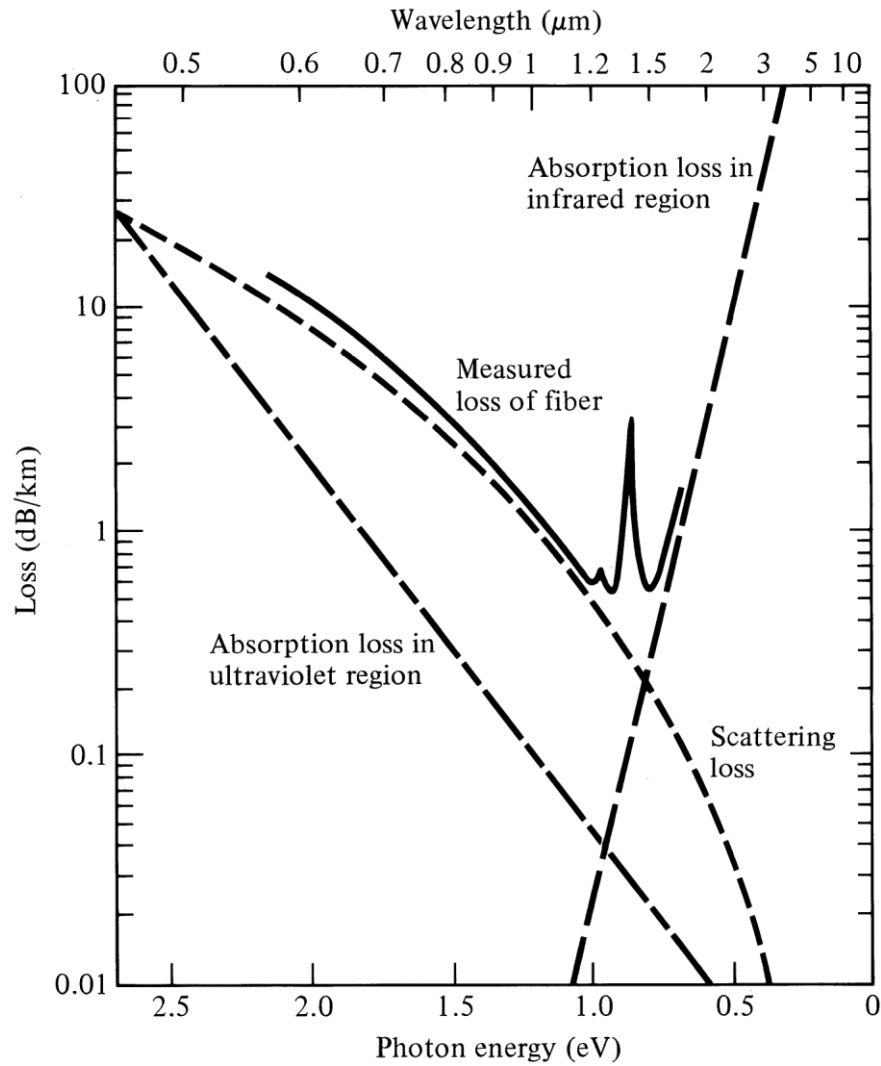

It is interesting to see that in the presence of various losses, there is a natural window in the optical spectrum where the loss is as low as 0.2-0.3dB/Km. This window is from 1200nm to 1600nm.

There is a local attenuation peak around 1400nm which is due to OH absorption. The low-loss window therefore is divided into sub-windows, one around 1300nm and other around 1550nm. In fact these are the windows which are the II and III generation windows of optical communication.

## MICRO-BENDING LOSSES

While commissioning the optical fiber is subjected to micro-bending as shown in Fig.

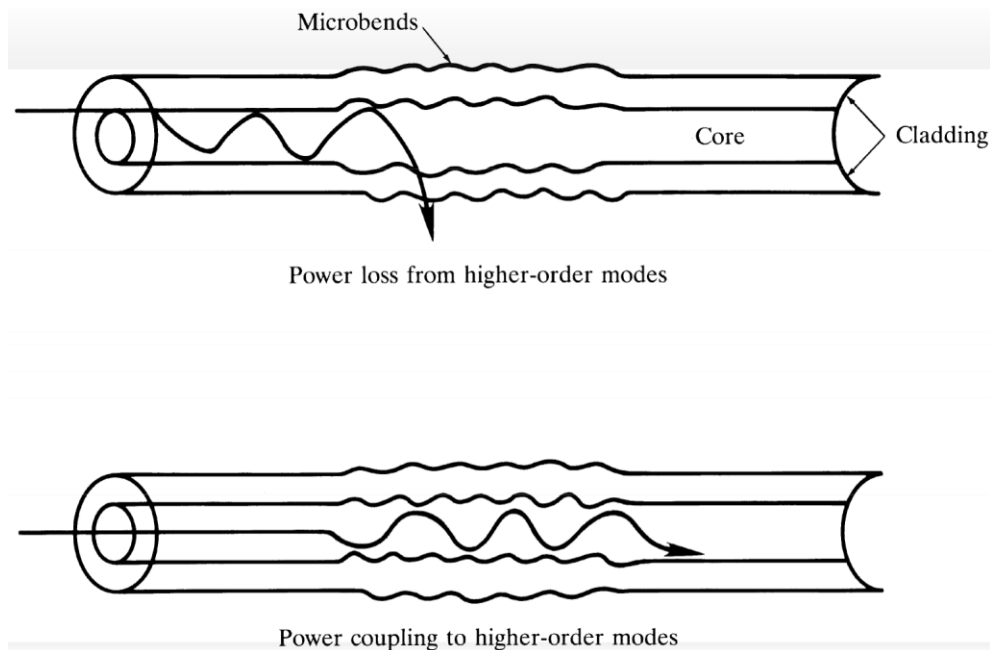

The analysis of micro-bends is a rather complex task. However, just for basic understanding of how the loss takes place due to micro-bending, we use following arguments.

In a fiber without micro-bends the light is guided by total internal reflection (ITR) at the core-cladding boundary. The rays which are guided inside the fiber has incident angle greater than the critical angle at the core-cladding interface. In the presence of micro-bends however, the direction of the local normal to the core-cladding interface deviates and therefore the rays may not have angle of incidence greater than the critical angle and consequently will be leaked out.

A part of the propagating optical energy therefore leaks out due to micro-bends.

Depending upon the roughness of the surface through which the fiber passes, the micro-bending loss varies.

Typically the micro-bends increase the fiber loss by 0.1-0.2 dB/Km.

## **RADIATION OR BENDING LOSS**

While laying the fiber the fiber may undergo a slow bend. In micro-bend the bending is on micron scale, whereas in a slow bend the bending is on cm scale. A typical example of a slow bend is a formation of optical fiber loop.

The loss mechanism due to bending loss can be well understood using modal propagation model.

As we have seen, the light inside a fiber propagates in the form of modes. The modal fields decay inside the cladding away from the core-cladding interface. Theoretically the field in the cladding is finite no matter how far away we are from the core-cladding interface. Now look at the amplitude and phase distribution for the fibers which are straight and which are bent over an circular arc as shown in Fig.

## Phase Fronts in a Straight Fiber

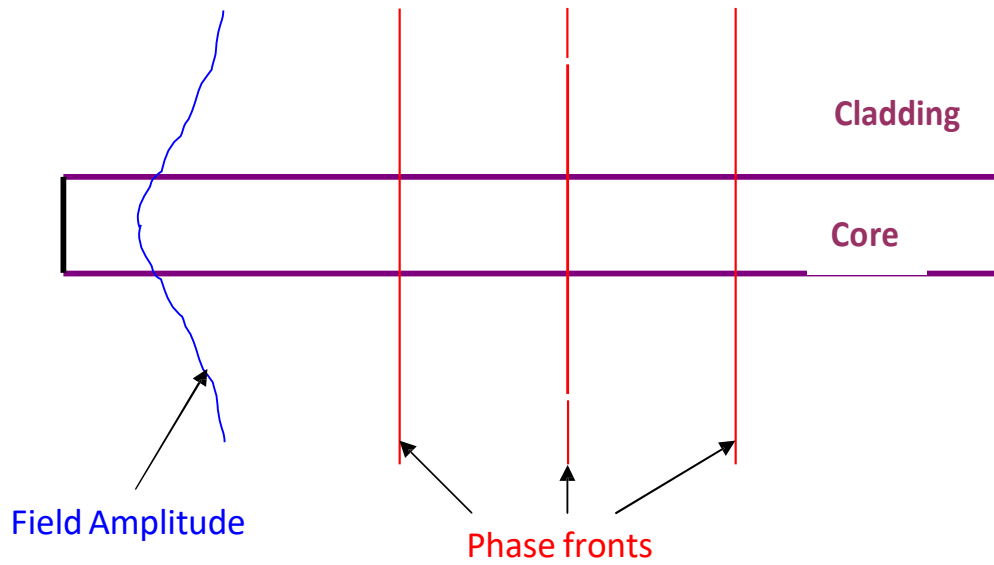

It can be noted that for the straight the phase fronts are parallel and each point on the phase front travels with the same phase velocity.

## Phase Fronts for a Bent Fiber

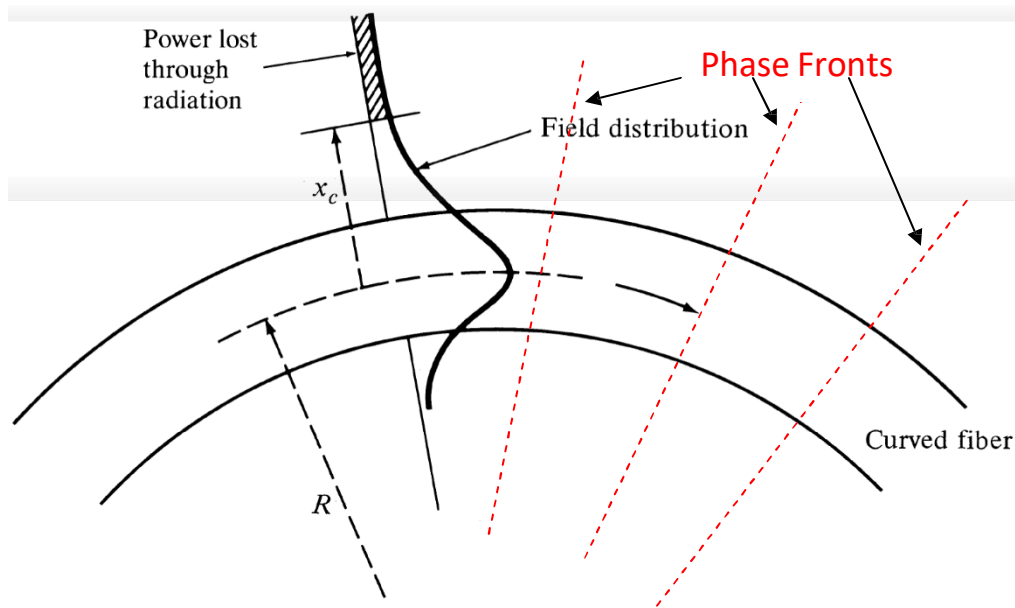

However, as soon the fiber is bent (no matter how gently) the phase fronts are no more parallel. The phase fronts move like a fan pivoted to the center of curvature of the bent fiber (see Fig.). Every point on the phase front consequently does not move with same velocity. The velocity increases as we move radially outwards the velocity of the phase front increases. Very quickly we reach to a distance  $x_c$  from the fiber where the velocity tries to become greater than the velocity of light in the cladding medium.

Since the velocity of energy can not be greater than velocity of light, the energy associated with the modal field beyond  $x_c$  gets detached from the mode and radiates away. This is called the bending or the radiation loss.

Following important things can be noted about the bending loss.

1. The radiation loss is present in every bent fiber no matter how gentle the bend is.
2. Radiation loss depends upon how much is the energy beyond  $x_c$ .
3. For a given modal field distribution if  $x_c$  reduces, the radiation loss increases. The  $x_c$  reduces as the radius of curvature of the bent fiber reduces, that is the fiber is sharply bent.
4. The number of modes therefore reduces in a multimode fiber in presence of bends.



# Light Emitting Diodes:-

## INTRODUCTION

Over the past 25 years the light-emitting diode (LED) has grown from a laboratory curiosity to a broadly used light source for signaling applications . In 1992 LED production reached a level of approximately 25 billion chips , and \$2 . 5 billion worth of LED-based components were shipped to original equipment manufacturers .

This article covers light-emitting diodes from the basic light-generation processes to descriptions of LED products . First , we will deal with light-generation mechanisms and light extraction . Four major types of device structures—from simple grown or diffused homojunctions to complex double heterojunction devices are discussed next , followed by a description of the commercially important semiconductors used for LEDs , from the pioneering GaAsP system to the AlGaInP system that is currently revolutionizing LED technology . Then processes used to fabricate LED chips are explained—the growth of GaAs and GaP substrates ; the major techniques used for growing the epitaxial material in which the light-generation processes occur ; and the steps required to create LED chips up to the point of assembly . Next the important topics of quality and reliability—in particular , chip degradation and package-related failure mechanisms—will be addressed . Finally , LED-based products , such as indicator lamps , numeric and alphanumeric displays , optocouplers , fiber-optic transmitters , and sensors , are described . This article covers the mainstream structures , materials , processes , and applications in use today . It does not cover certain advanced structures , such as quantum well or strained layer devices , The reader is also referred to for current information on edge-emitting LEDs , whose fabrication and use are similar to lasers .

Schematic:

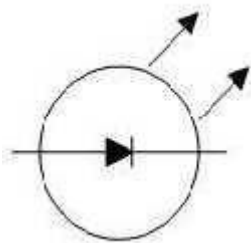

Theory:

A Light emitting diode (LED) is essentially a pn junction diode. When carriers are injected across a forward-biased junction, it emits incoherent light. Most of the commercial LEDs are realized using a highly doped n and a p Junction.

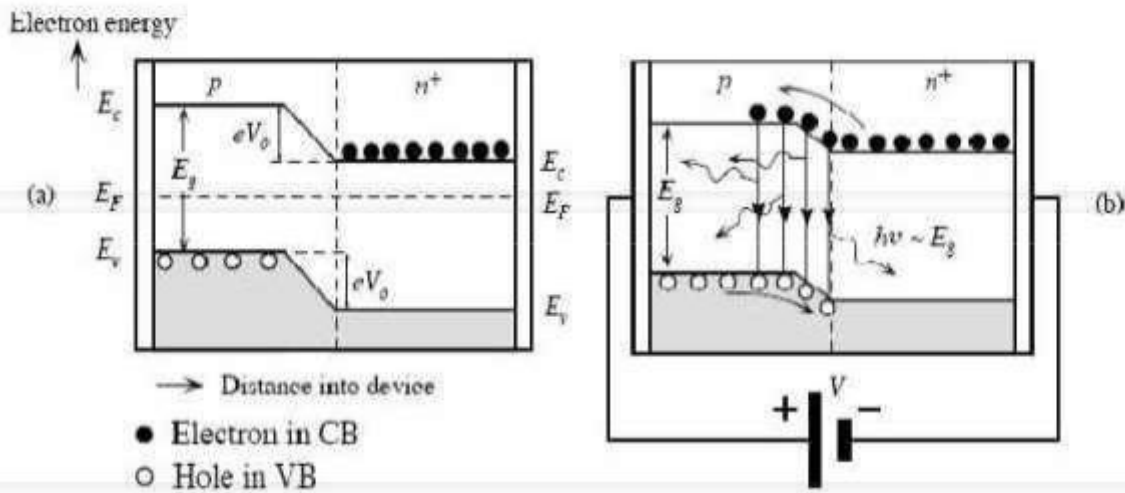

(a) The energy band diagram of a  $pn^+$  (heavily  $n$ -type doped) junction without any bias. Built-in potential  $V_0$  prevents electrons from diffusing from  $n^+$  to  $p$  side. (b) The applied bias reduces  $V_0$  and thereby allows electrons to diffuse or be injected into the  $p$ -side. Recombination around the junction and within the diffusion length of the electrons in the  $p$ -side leads to photon emission.

**Figure 1: p-n+ Junction under Unbiased and biased conditions**

To understand the principle, let's consider an unbiased  $pn^+$  junction (Figure 1 shows the  $pn^+$  energy band diagram). The depletion region extends mainly into the  $p$ -side. There is a potential barrier from  $E_c$  on the  $n$ -side to the  $E_c$  on the  $p$ -side, called the built-in voltage,  $V_0$ . This potential barrier prevents the excess free electrons on the  $n^+$  side from diffusing into the  $p$  side. When a Voltage  $V$  is applied across the junction, the built-in potential is reduced from  $V_0$  to  $V_0 - V$ . This allows the electrons from the  $n^+$  side to get injected into the  $p$ -side. Since electrons are the minority carriers in the  $p$ -side, this process is called minority carrier injection. But the hole injection from the  $p$  side to  $n^+$  side is very less and so the current is primarily due to the flow of electrons into the  $p$ -side. These electrons injected into the  $p$ -side recombine with the holes. This recombination results in spontaneous emission of photons (light). This effect is called injection electroluminescence. These photons should be allowed to escape from the device without being reabsorbed.

The recombination can be classified into the following two kinds

- Direct recombination
- Indirect recombination

Direct Recombination:

In direct band gap materials, the minimum energy of the conduction band lies directly above the maximum energy of the valence band in momentum space energy. In this material, free electrons at the bottom of the conduction band can recombine directly with free holes at the top of the valence band, as the momentum of the two particles is the same. This transition from conduction band to valence band involves photon emission (takes care of the principle of energy conservation). This is known as direct recombination. Direct recombination occurs spontaneously. GaAs is an example of a direct band-gap material.

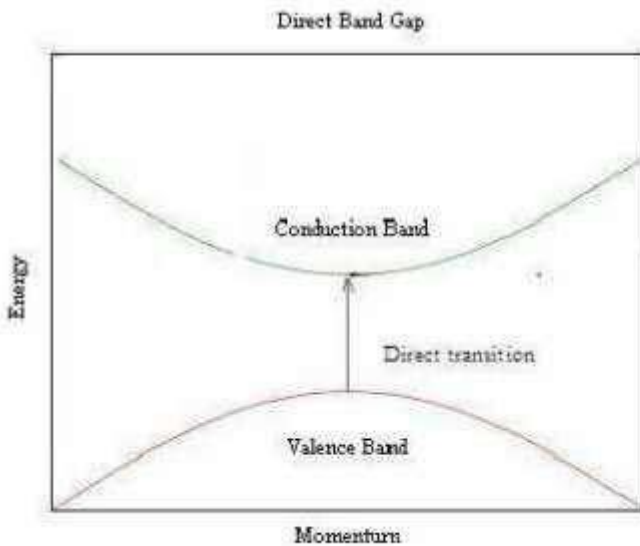

**Radiative recombination in a direct band-gap semiconductor**

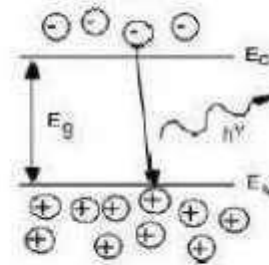

**Figure 2: Direct Bandgap and Direct Recombination**

Indirect Recombination:

In the indirect band gap materials, the minimum energy in the conduction band is shifted by a k-vector relative to the valence band. The k-vector difference represents a difference in momentum. Due to this difference in momentum, the probability of direct electronhole recombination is less.

In these materials, additional dopants(impurities) are added which form very shallow donor states. These donor states capture the free electrons locally; provides the necessary momentum shift for recombination. These donor states serve as the recombination centers. This is called Indirect (non-radiative) Recombination.

Nitrogen serves as a recombination center in GaAsP. In this case it creates a donor state, when SiC is doped with Al, it recombination takes place through an acceptor level. when SiC is doped with Al, it recombination takes place through an acceptor level.

The indirect recombination should satisfy both conservation energy, and momentum.

Thus besides a photon emission, phonon emission or absorption has to take place.

GaP is an example of an indirect band-gap material.

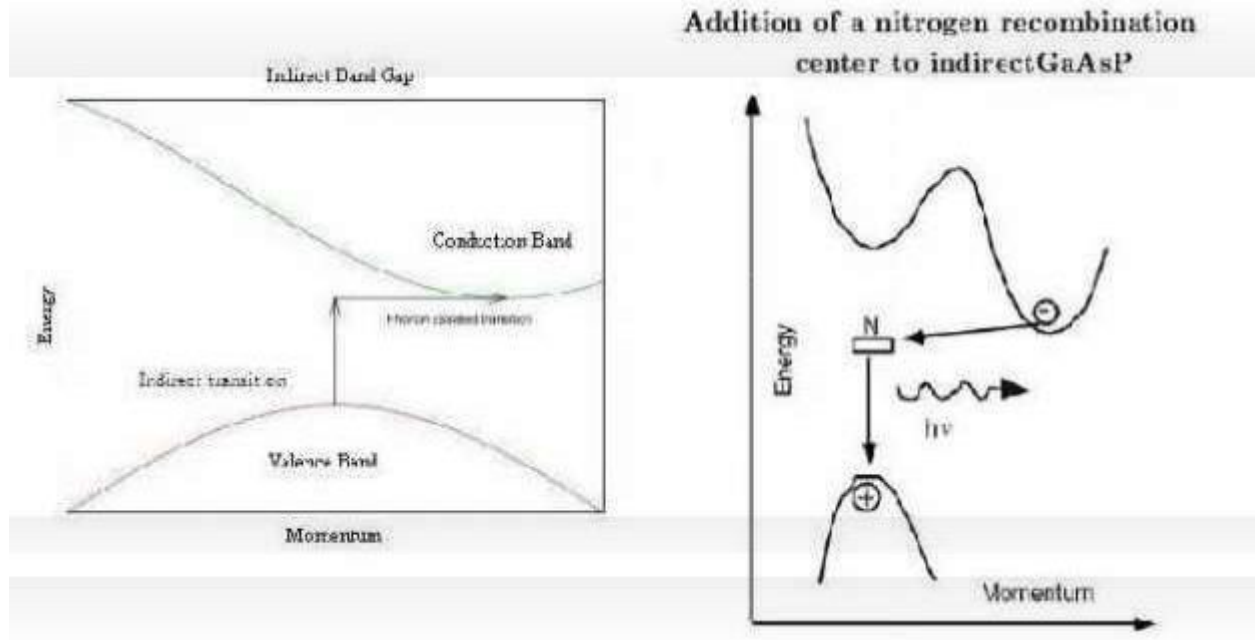

**Figure 3: Indirect Bandgap and NonRadiative recombination**

The wavelength of the light emitted, and hence the color, depends on the band gap energy of the materials forming the p-n junction.

The emitted photon energy is approximately equal to the band gap energy of the semiconductor. The following equation relates the wavelength and the energy band gap.

$$h\nu = E_g$$

$$hc/\lambda = E_g$$

$$\lambda = hc/E_g$$

Where  $h$  is Planck's constant,  $c$  is the speed of the light and  $E_g$  is the energy band gap. Thus, a semiconductor with a 2 eV band-gap emits light at about 620 nm, in the red. A 3 eV band-gap material would emit at 414 nm, in the violet.

**LED Materials:**

An important class of commercial LEDs that cover the visible spectrum are the III-V ternary alloys based on alloying GaAs and GaP which are denoted by GaAs<sub>1-y</sub>Py.

InGaAlP is an example of a quaternary (four element) III-V alloy with a direct band gap.

The LEDs realized using two differently doped semiconductors that are the same material is called a homojunction. When they are realized using different bandgap materials they are called a heterostructure device. A heterostructure LED is brighter than a homojunction LED.

**LED Structure:**

The LED structure plays a crucial role in emitting light from the LED surface. The LEDs are structured to ensure most of the recombinations takes place on the surface by the following two ways.

- By increasing the doping concentration of the substrate, so that additional free minority charge carriers electrons move to the top, recombine and emit light at the surface.

• By increasing the diffusion length  $L = \sqrt{D\tau}$ , where  $D$  is the diffusion coefficient and  $\tau$  is the carrier life time. But when increased beyond a critical length there is a chance of re-absorption of the photons into the device.

The LED has to be structured so that the photons generated from the device are emitted without being reabsorbed. One solution is to make the p layer on the top thin, enough to create a depletion layer. Following picture shows the layered structure. There are different ways to structure the dome for efficient emitting.

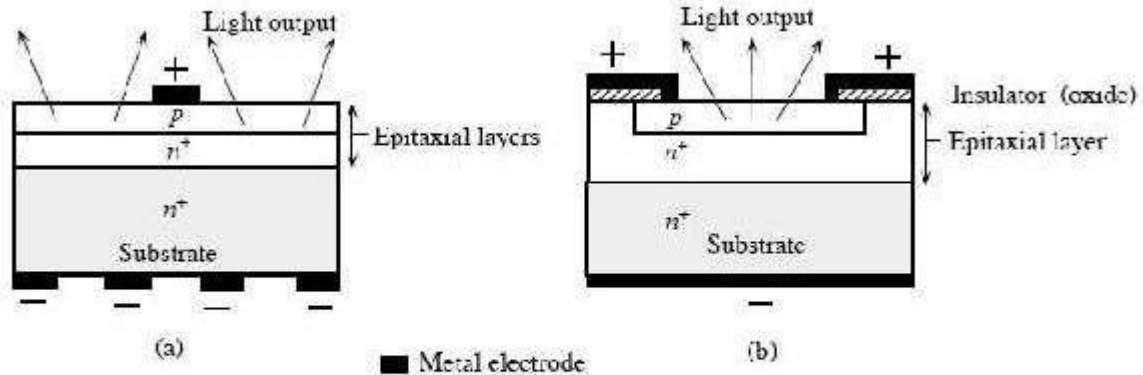

A schematic illustration of typical planar surface emitting LED devices. (a)  $p$ -layer grown epitaxially on an  $n^+$  substrate. (b) First  $n^+$  is epitaxially grown and then  $p$  region is formed by dopant diffusion into the epitaxial layer.

### LED structure

LEDs are usually built on an  $n$ -type substrate, with an electrode attached to the  $p$ -type layer deposited on its surface.  $P$ -type substrates, while less common, occur as well. Many commercial LEDs, especially GaN/InGaN, also use sapphire substrate.

LED efficiency:

A very important metric of an LED is the external quantum efficiency  $\eta_{ext}$ . It quantifies the efficiency of the conversion of electrical energy into emitted optical energy. It is defined as the light output divided by the electrical input power. It is also defined as the product of Internal radiative efficiency and Extraction efficiency.

$$\eta_{ext} = P_{out}(\text{optical}) / IV$$

For indirect bandgap semiconductors  $\eta_{ext}$  is generally less than 1%, where as for a direct band gap material it could be substantial.

$$\eta_{int} = \text{rate of radiation recombination} / \text{Total recombination}$$

The internal efficiency is a function of the quality of the material and the structure and composition of the layer.

Applications: LED have a lot of applications. Following are few examples.

- Devices, medical applications, clothing, toys
- Remote Controls (TVs, VCRs)
- Lighting
- Indicators and signs
- Optoisolators and optocouplers
- Swimming pool lighting

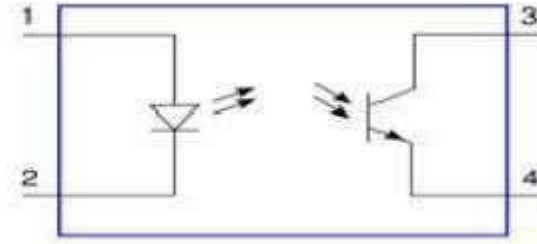

### Optocoupler schematic showing LED and phototransistor

Advantages of using LEDs:

- LEDs produce more light per watt than incandescent bulbs; this is useful in battery powered or energy-saving devices.
- LEDs can emit light of an intended color without the use of color filters that traditional lighting methods require. This is more efficient and can lower initial costs.
- The solid package of the LED can be designed to focus its light. Incandescent and fluorescent sources often require an external reflector to collect light and direct it in a usable manner.
  - When used in applications where dimming is required, LEDs do not change their color tint as the current passing through them is lowered, unlike incandescent lamps, which turn yellow.
- LEDs are ideal for use in applications that are subject to frequent on-off cycling, unlike fluorescent lamps that burn out more quickly when cycled frequently, or High Intensity Discharge (HID) lamps that require a long time before restarting.
- LEDs, being solid state components, are difficult to damage with external shock. Fluorescent and incandescent bulbs are easily broken if dropped on the ground.
- LEDs can have a relatively long useful life. A Philips LUXEON k2 LED has a life time of about 50,000 hours, whereas Fluorescent tubes typically are rated at about 30,000 hours, and incandescent light bulbs at 1,000–2,000 hours.
- LEDs mostly fail by dimming over time, rather than the abrupt burn-out of incandescent bulbs.
- LEDs light up very quickly. A typical red indicator LED will achieve full brightness in microseconds; Philips Lumileds technical datasheet DS23 for the Luxeon Star states "less than 100ns." LEDs used in communications devices can have even faster response times.
- LEDs can be very small and are easily populated onto printed circuit boards.
- LEDs do not contain mercury, unlike compact fluorescent lamps.

Disadvantages:

- LEDs are currently more expensive, price per lumen, on an initial capital cost basis, than more conventional lighting technologies. The additional expense partially stems from the relatively low lumen output and the drive circuitry and power supplies needed. However, when considering the total cost of ownership (including energy and maintenance costs), LEDs far surpass incandescent or halogen sources and begin to threaten the future existence of compact fluorescent lamps.
- LED performance largely depends on the ambient temperature of the operating environment. Over-driving the LED in high ambient temperatures may result in overheating of the LED package, eventually leading to device failure. Adequate heat-sinking is required to maintain long life.
- LEDs must be supplied with the correct current. This can involve series resistors or current-regulated power supplies.

- LEDs do not approximate a "point source" of light, so they cannot be used in applications needing a highly collimated beam. LEDs are not capable of providing divergence below a few degrees. This is contrasted with commercial ruby lasers with divergences of 0.2 degrees or less. However this can be corrected by using lenses and other optical devices.

**Laser diodes:-**

Laser diodes (also called injection lasers.) are in effect a specialised form of LED. Just like a LED, they're a form of P-N junction diode with a thin depletion layer where electrons and holes collide to create light photons, when the diode is forward biased.

The difference is that in this case the active part of the depletion layer (i.e., where most of the current flows) is made quite narrow, to concentrate the carriers. The ends of this narrow active region are also highly polished, or coated with multiple very thin reflective layers to act as mirrors, so it forms a resonant optical cavity.

The forward current level is also increased, to the point where the current density reaches a critical level where carrier population inversion occurs. This means there are more holes than electrons in the conduction band, and more electrons than holes in the valence band. In other words, a very large excess population of electrons and holes which can potentially combine to release photons. And when this happens, the creation of new photons can be triggered not just by random collisions of electrons and holes, but also by the influence of passing photons. Passing photons are then able to stimulate the production of more photons, without themselves being absorbed. So laser action is able to occur: Light Amplification by Stimulated Emission of Radiation. And the important thing to realise is that the photons that are triggered by other passing photons have the same wavelength, and are also in phase with them. In other words, they end up in sync and forming continuous-wave coherent radiation.

Because of the resonant cavity, photons are thus able to travel back and forth from one end of the active region to the other, triggering the production of more and more photons in sync with themselves. So quite a lot of coherent light energy is generated.

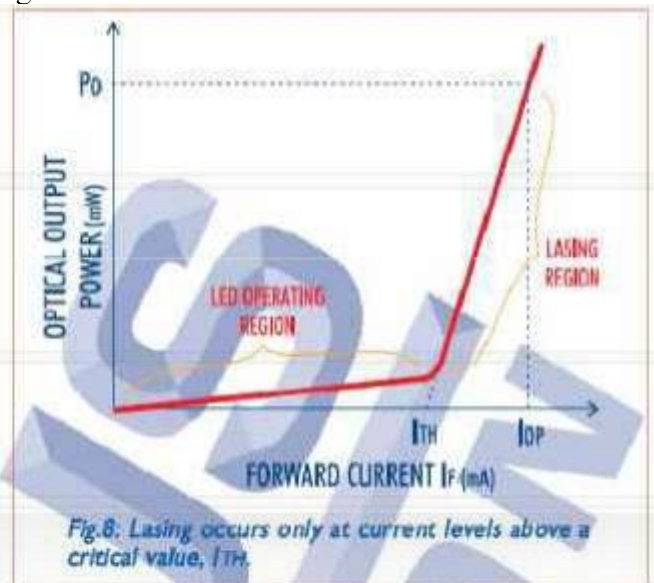
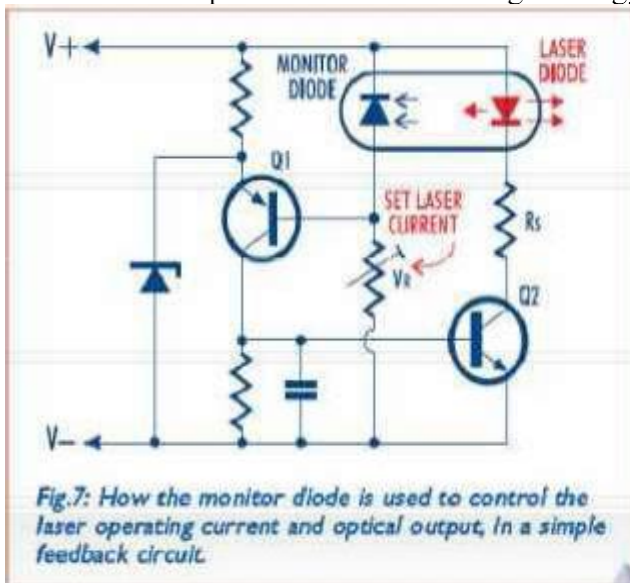

And as the ends of the cavity are not totally reflective (typically about 90-95%), some of this coherent light can leave the laser chip to form its output beam.

Because a laser's light output is coherent, it is very low in noise and also more suitable for use as a carrier for data communications. The bandwidth also tends to be narrower and better defined

than LEDs, making them more suitable for optical systems where light beams need to be separated or manipulated on the basis of wavelength.

The very compact size of laser diodes makes them very suitable for use in equipment like CD, DVD and MiniDisc players and recorders. As their light is reasonably well collimated (although not as well as gas lasers) and easily focussed, they're also used in optical levels, compact handheld laser pointers, barcode scanners etc. There are two main forms of laser diode: the horizontal type, which emits light from the polished ends of the chip, and the vertical or surface emitting type. They both operate in the way just described, differing mainly in terms of the way the active light generating region and resonant cavity are formed inside the chip. Because laser diodes have to be operated at such a high current density, and have a very low forward resistance when lasing action occurs, they are at risk of destroying themselves due to thermal runaway. Their operating light density can also rise to a level where the end mirrors can begin melting. As a result their electrical operation must be much more carefully controlled than a LED. This means that not only must a laser diode's current be regulated by a constant current circuit rather than a simple series resistor, but optical negative feedback must generally be used as well to ensure that the optical output is held to a constant safe level.

To make this optical feedback easier, most laser diodes have a silicon PIN photodiode built right into the package, arranged so that it automatically receives a fixed proportion of the laser's output. The output of this monitor diode can then be used to control the current fed through the laser by the constant current circuit, for stable and reliable operation. Fig.6 shows a typical horizontal type laser chip mounted in its package, with the monitor photodiode mounted on the base flange below it so the diode receives the light output from the rear of the laser chip.

Fig.7 (page 3) shows a simple current regulator circuit used to operate a small laser diode, and you can see how the monitor photodiode is connected. The monitor diode is shunting the base forward bias for transistor Q1, which has

its emitter voltage fixed by the zener diode. So as the laser output rises, the monitor diode current increases, reducing the conduction of Q1 and hence that of transistor Q2, which controls the laser current. As a result, the laser current is automatically stabilised to a level set by adjustable resistor VR.

#### Laser diode parameters

Perhaps the key parameter for a laser diode is the threshold current ( $I_{TH}$ ), which is the forward current level where lasing actually begins to occur. Below that current level the device delivers some light output, but it operates only as a LED rather than a laser. So the light it does produce in this mode is incoherent. Another important parameter is the rated light output ( $P_o$ ), which is the highest recommended light output level (in milliwatts) for reliable continuous operation. Not surprisingly there's an operating current level ( $I_{OP}$ ) which corresponds to this rated light output (Fig.8). There's also the corresponding current output from the feedback photodiode, known as the monitor current level ( $I_m$ ). Other parameters usually given for a laser diode are its peak lasing wavelength, usually given in nanometres (nm); and its beam divergence angles (defined as the angle away from the beam axis before the light intensity drops to 50%), in the X and Y directions (parallel to, and normal to the chip plane).

#### Laser safety

Although most of the laser diodes used in electronic equipment have quite low optical output levels, typically less than 5mW (milliwatts), their output is generally concentrated in a relatively narrow beam. This means that it is still capable of causing damage to a human or animal eye, and particularly to its light-sensitive retina.

Infra-red (IR) lasers are especially capable of causing eye damage, because their light is not visible. This prevents the eye's usual protective reflex mechanisms (iris contraction, eyelid closure) from operating. So always take special care when using devices like laser pointers, and especially when working on equipment which includes IR lasers, to make sure that the laser beam cannot enter either your own, or anyone else's eyes. If you need to observe the output from a laser, either use protective filter goggles or use an IR-sensitive CCD type video camera. Remember that eye damage is often irreversible, especially when it's damage to the retina.

•Light Emitting Diode

- Light is mostly monochromatic (narrow energy spread comparable to the distribution of electrons/hole populations in the band edges)
- Light is from spontaneous emission (random events in time and thus phase).
- Light diverges significantly

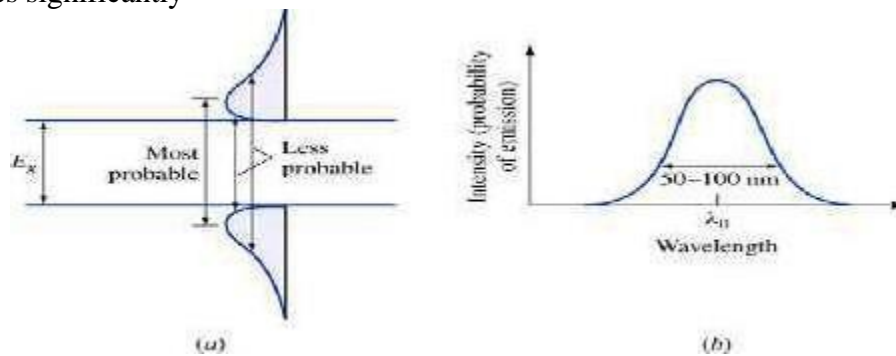

LASER

- Light is essentially single wavelength (highly monochromatic)
- Light is from “stimulated emission” (timed to be in phase with other photons)
- Light has significantly lower divergence (Semiconductor versions have more than gas lasers though).

Spontaneous Light Emission

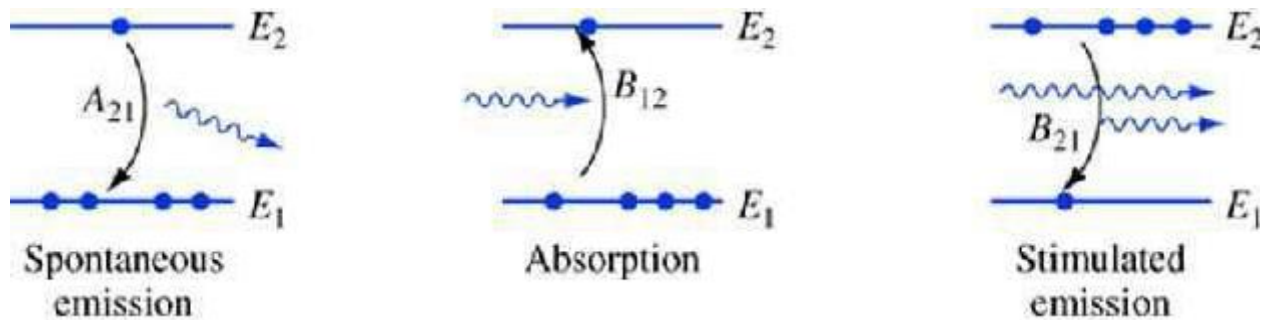

- We can add to our understanding of absorption and spontaneous radiation due to random recombination another form of radiation – Stimulated emission.
  - **Stimulated emission can occur when we have a “population inversion”, i.e. when we have injected so many minority carriers that in some regions there are more “excited carriers” (electrons) than “ground state” carriers (holes).**
  - **Given an incident photon of the band gap energy, a second photon will be “stimulated” by the first photon resulting in two photons with the same energy (wavelength) and phase.**

- This phase coherence results in minimal divergence of the optical beam resulting in a directed light source.

**Spontaneous vs Stimulated Light Emission:**

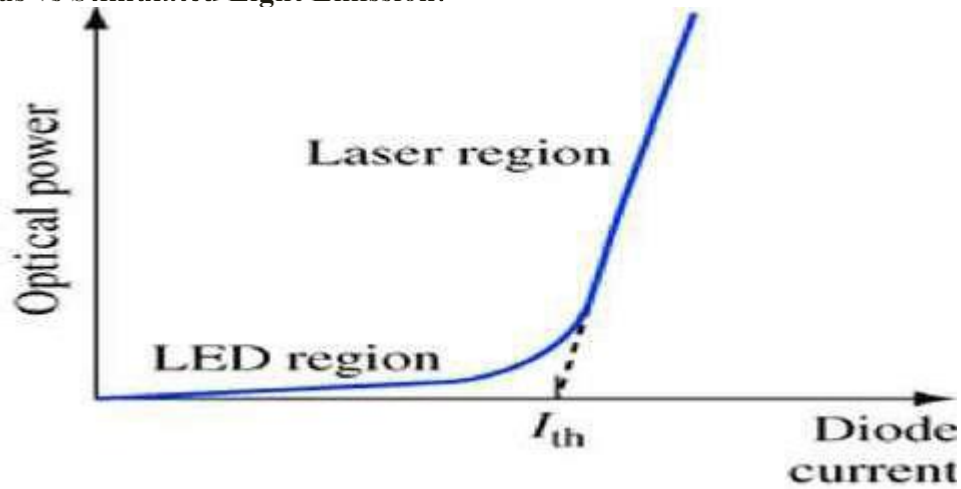

The power-current curve of a laser diode. Below threshold, the diode is an LED. Above threshold, the population is inverted and the light output increases rapidly.

**LASER Wavelength Design:**

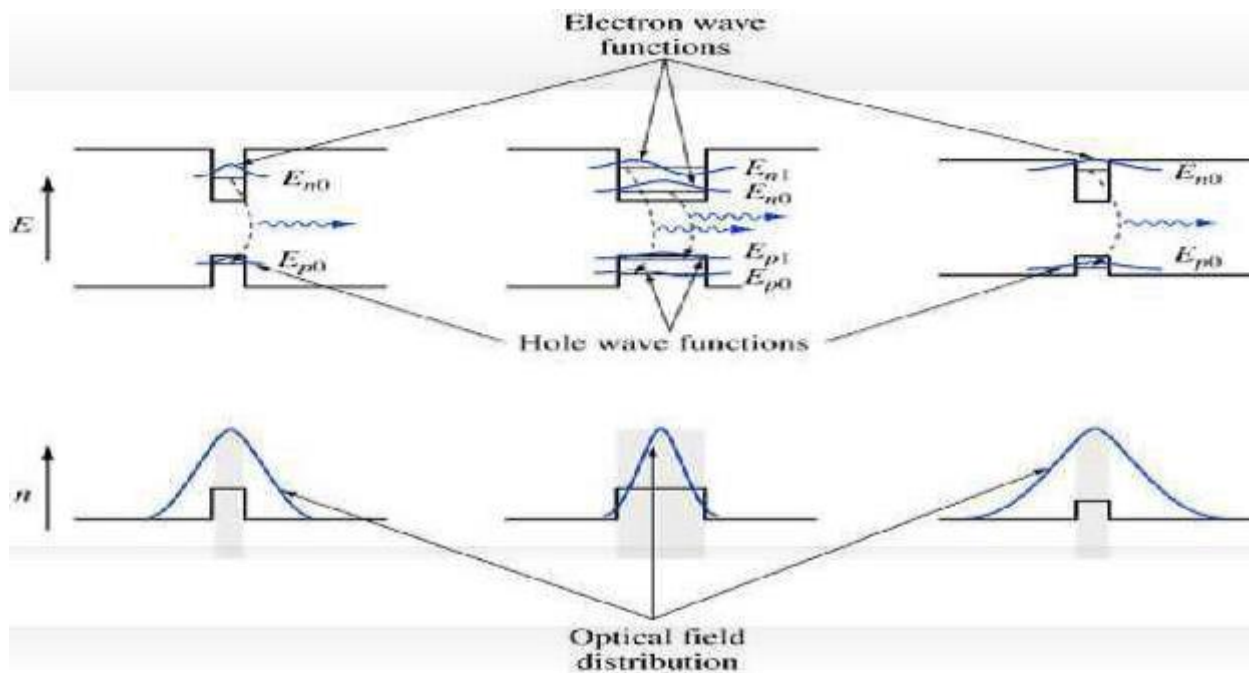

Adjusting the depth and width of quantum wells to select the wavelength of emission is one form of band-gap engineering. The shaded areas indicate the width of the well to illustrate the degree of confinement of the mode.

## Advanced LASER Wavelength Design:

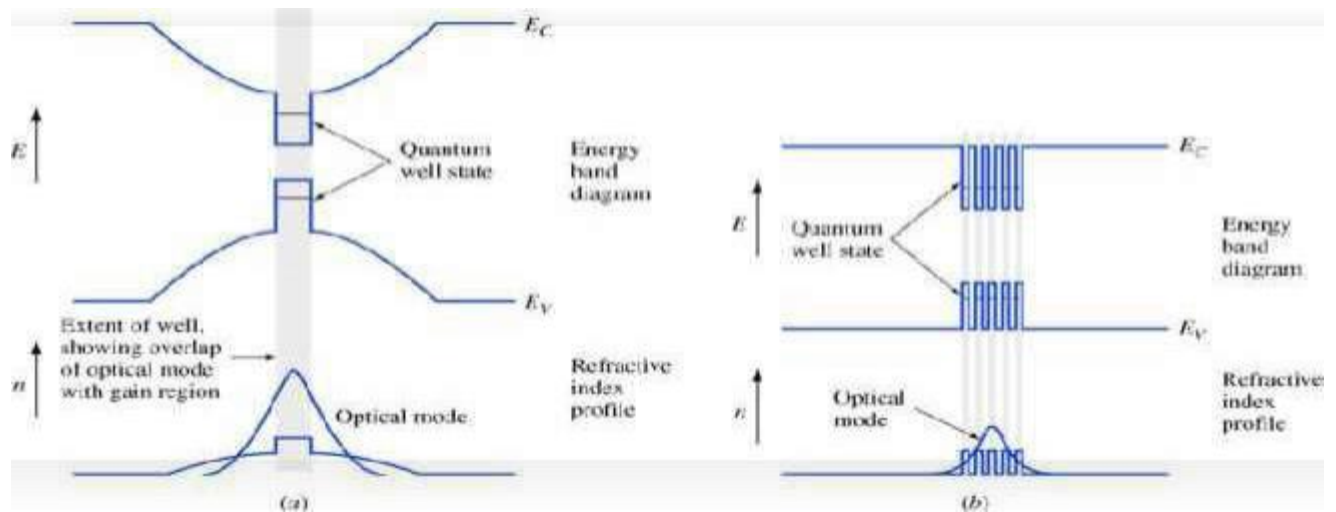

(a) A GRINSCH structure helps funnel the carriers into the wells to improve the probability of recombination. Additionally, the graded refractive index helps confine the optical mode in the nearwell region. Requires very precise control over layers due to grading. Almost always implemented via MBE

(b) A multiple quantum well structure has improves carrier capture.

Sometimes the two are combined to give a “digitally graded” device where only two compositions are used but the well thicknesses are varied to implement an effective “index grade”

## Photodetectors:-

These are **Opto-electric devices** i.e. to convert the optical signal back into electrical impulses.

The light detectors are commonly made up of semiconductor material.

When the light strikes the light detector a current is produced in the external circuit proportional to the intensity of the incident light.

Optical signal generally is **weakened** and distorted when it emerges from the end of the fiber, **the photodetector must meet following strict performance requirements.**

A **high sensitivity** to the emission wavelength range of the received light signal.

A **minimum** addition of **noise** to the signal.

A **fast response** speed to handle the desired data rate.

Be **insensitive** to **temperature** variations.

Be **compatible** with the physical dimensions of the **fiber**.

Have a **Reasonable cost** compared to other system components.

Have a long **operating lifetime**.

Some important parameters while discussing photodetectors:

### Quantum Efficiency

It is the ratio of primary electron-hole pairs created by incident photon to the photon incident on the diode material.

### Detector Responsivity

This is the ratio of output current to input optical power. Hence this is the efficiency of the device.

### Spectral Response Range

This is the range of wavelengths over which the device will operate.

### Types of Light Detectors

- \_ PIN Photodiode
- \_ Avalanche Photodiode



### The Pin Photodetector:-

The **device structure** consists of **p and n** semiconductor regions separated by a very **lightly n-doped intrinsic (i) region**.

In **normal operation** a reverse-bias voltage is applied across the device so that **no free electrons or holes** exist in the **intrinsic region**.

**Incident photon** having energy **greater than or equal** to the **bandgap energy** of the semiconductor material, **give up its energy** and **excite an electron** from the valence band to the conduction band.

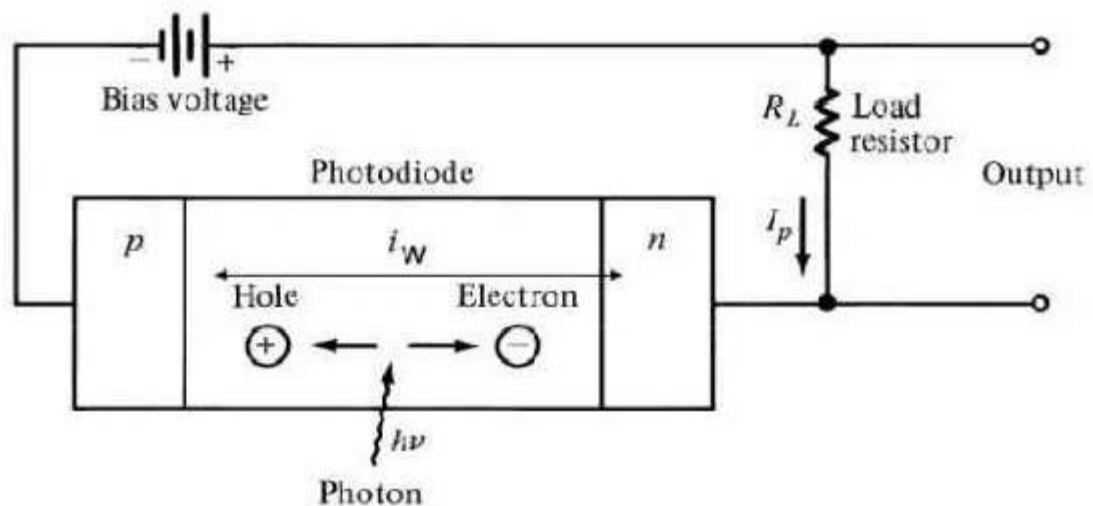

The high electric field present in the depletion region causes photogenerated carriers to separate and be collected across the reverse – biased junction. This gives rise to a current flow in an external circuit, known as **photocurrent**.

**Photocarriers:**

Incident photon, generates free (mobile) **electron-hole pairs in the intrinsic region**. These charge carriers are known as **photocarriers**, since they are generated by a photon.

**Photocurrent:**

The electric field across the device causes the **photocarriers to be swept out of the intrinsic region**, thereby giving rise to a **current flow in an external circuit**. This current flow is known as the **photocurrent**.

Energy-Band diagram for a *pin* photodiode:

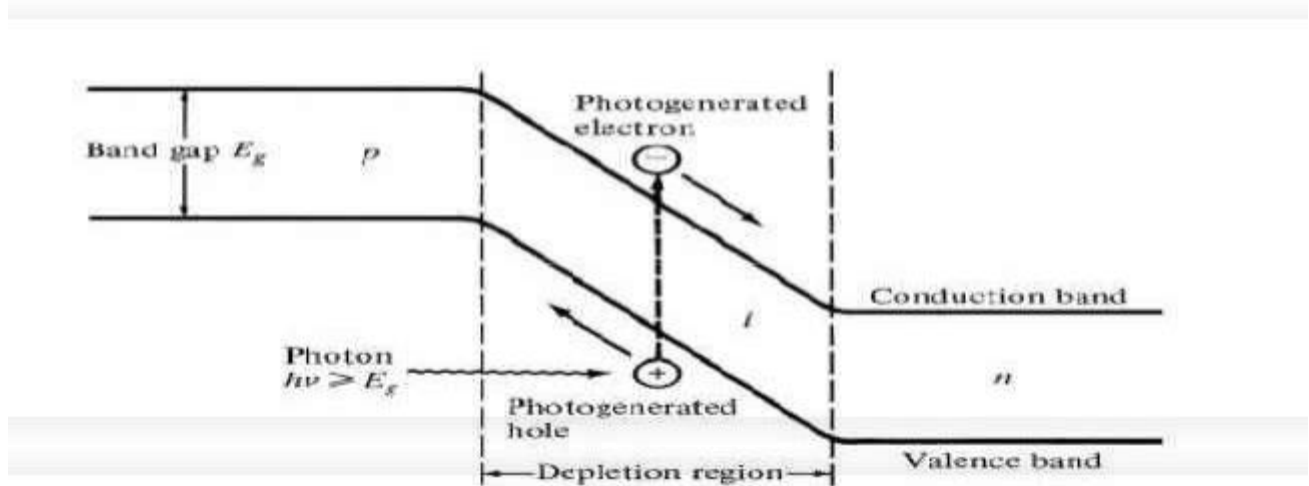

An incident photon is able to boost an electron to the conduction band only if it has an energy that is greater than or equal to the bandgap energy

Thus, a particular semiconductor material can be used only over a limited wavelength range.

$$\lambda_c = \frac{hc}{E_g}$$

As the charge carriers flow through the material some of them recombine and disappear.

The charge carriers move a distance  $L_n$  or  $L_p$  for electrons and holes before recombining. This distance is known as diffusion length

The time it take to recombine is its life time  $\tau_n$  or  $\tau_p$  respectively.

$$L_n = (D_n \tau_n)^{1/2} \quad \text{and} \quad L_p = (D_p \tau_p)^{1/2}$$

Where  $D_n$  and  $D_p$  are the diffusion coefficients for electrons and holes respectively.

**Photocurrent:-**

As a photon flux penetrates through the semiconductor, it will be absorbed.

If  $P_{in}$  is the optical power falling on the photo detector at  $x=0$  and  $P(x)$  is the power level at a distance  $x$  into the material then the incremental change be given as

$$dP(x) = -\alpha_s(\lambda)P(x)dx$$

where  $\alpha_s(\lambda)$  is the photon absorption coefficient at a wavelength  $\lambda$ . So that

$$P(x) = P_{in} \exp(-\alpha_s x)$$

Optical power absorbed,  $P(x)$ , in the depletion region can be written in terms of incident optical power,  $P_{in}$ :

$$P(x) = P_{in} (1 - e^{-\alpha_s(\lambda)x})$$

Absorption coefficient as (1) strongly depends on wavelength. The upper wavelength cutoff for any semiconductor can be

$$\lambda_c (\mu m) = \frac{1.24}{E_g (eV)}$$

Taking entrance face reflectivity into consideration, the absorbed power in the width of depletion region,  $w$ , becomes:

$$(1 - R_f)P(w) = P_{in}(1 - e^{-\alpha_s(\lambda)w})(1 - R_f)$$

## Optical Absorption Coefficient

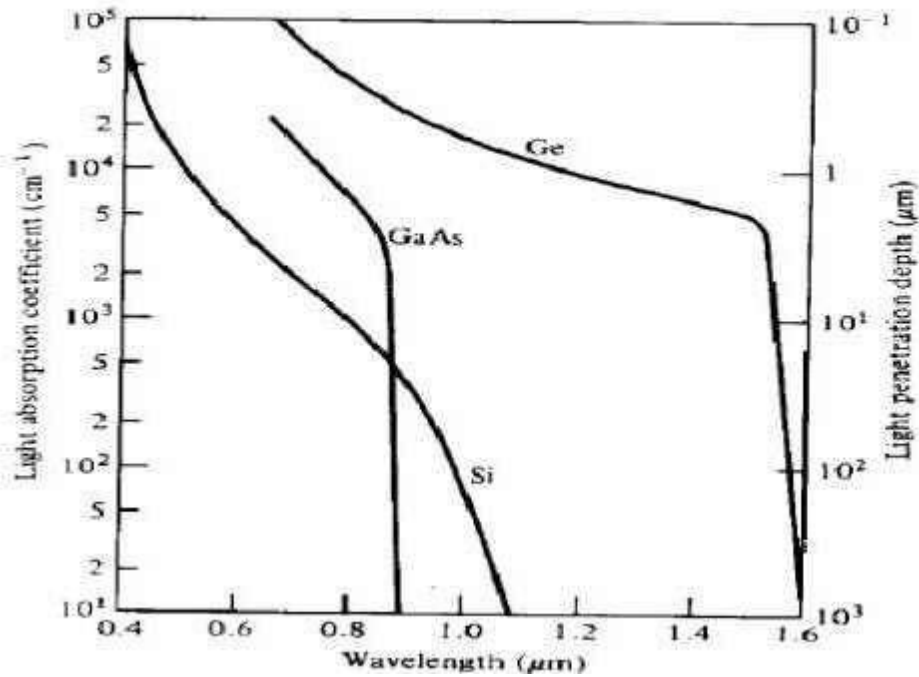

The primary photocurrent resulting from absorption is:

$$I_p = \frac{q}{h\nu} P_{in} (1 - e^{-\alpha_s(\lambda)w}) (1 - R_f)$$

Quantum Efficiency:

$$\eta = \frac{\text{\# of electron - hole photogenerated pairs}}{\text{\# of incident photons}}$$

$$\eta = \frac{I_p / q}{P_{in} / h\nu}$$

Responsivity:

$$\mathfrak{R} = \frac{I_p}{P_{in}} = \frac{\eta q}{h\nu} \quad [\text{A/W}]$$

## Responsivity vs. wavelength

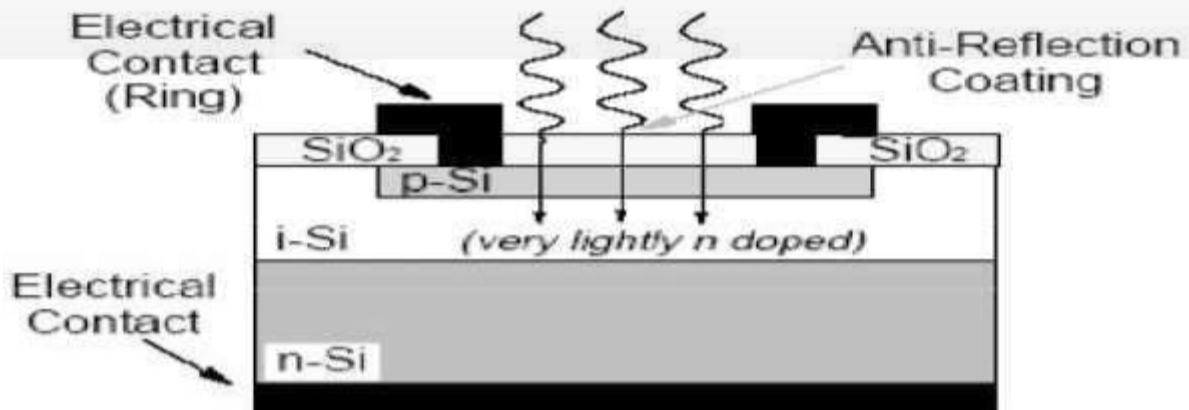
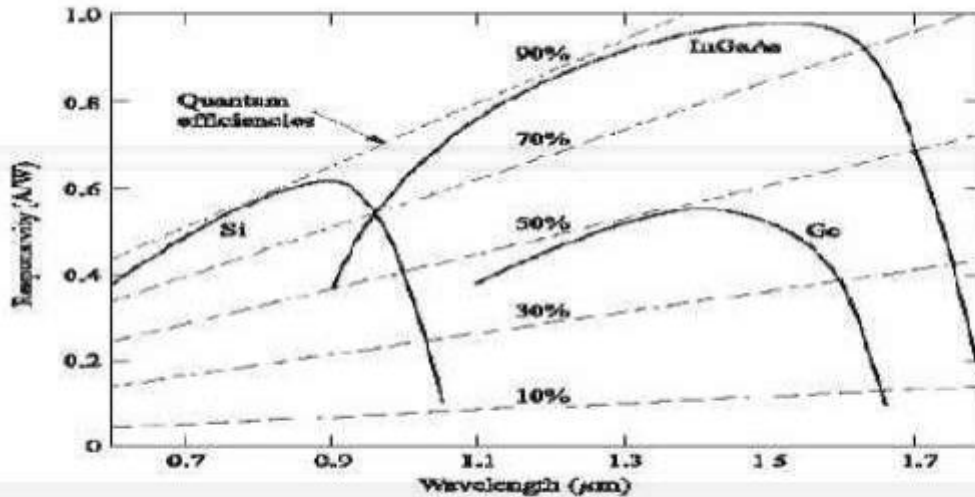

Typical Silicon P-I-N Diode Schematic

### Avalanche Photodiode (APD):

APDs internally multiply the primary photocurrent before it enters to following circuitry. In order to carrier multiplication take place, the photogenerated carriers must traverse along a high field region. In this region, photogenerated electrons and holes gain enough energy to ionize bound electrons in VB upon colliding with them. This multiplication is known as impact ionization. The newly created carriers in the presence of high electric field result in more ionization called avalanche effect.

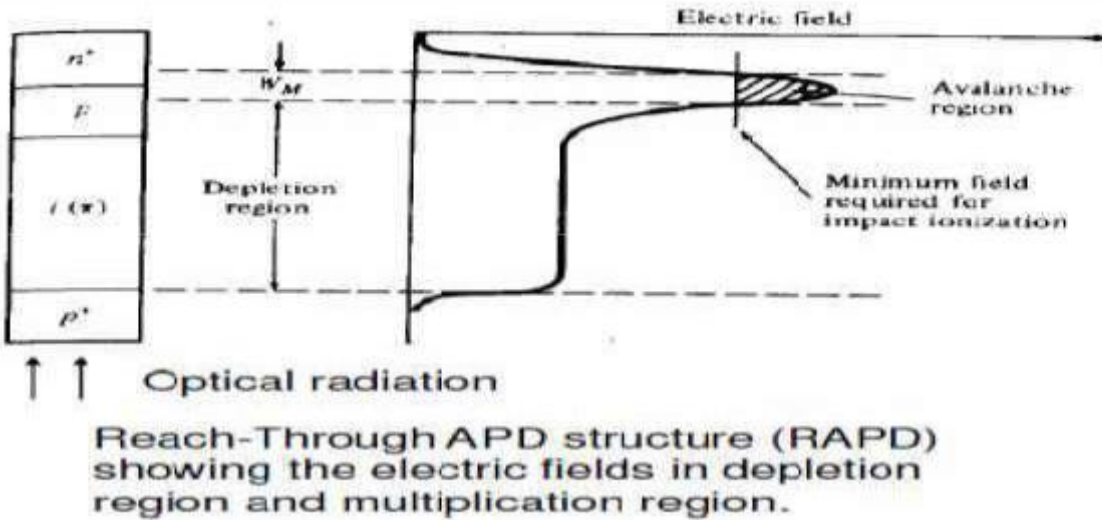

## Responsivity of APD:

The multiplication factor (current gain)  $M$  for all carriers generated in the photodiode is defined as:

$$M = \frac{I_M}{I_p}$$

where  $I_M$  is the average value of the total multiplied output current &  $I_p$  is the primary photocurrent.

The responsivity of APD can be calculated by considering the current gain as:

$$\mathfrak{R}_{APD} = \frac{\eta q}{h \nu} M = \mathfrak{R}_0 M$$

## Photodetector Noise & S/N:-

Detection of weak optical signal requires that the photodetector and its following amplification circuitry be optimized for a desired signal-to-noise ratio.

It is the noise current which determines the minimum optical power level that can be detected. This minimum detectable optical power defines the **sensitivity** of photodetector. That is the optical power that generates a photocurrent with the amplitude equal to that of the total noise current ( $S/N=1$ )

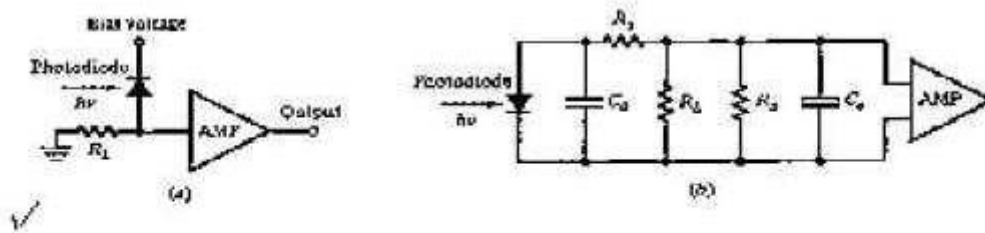

$$\frac{S}{N} = \frac{\text{signal power from photocurrent}}{\text{photodiode noise power + amplifier noise power}}$$

$$\frac{S}{N} = \frac{\langle i_p^2 \rangle M^2}{2q(I_p + I_D)BM^2 F(M) + 2qI_L B + 4k_B T B / R_L}$$

Since the noise figure  $F(M)$  increases with  $M$ , there always exists an optimum value of  $M$  that maximizes the  $S/N$ . For sinusoidally modulated signal with  $m=1$  and

$$F(M) \approx M^x$$

$$M_{opt}^{x+2} = \frac{2qI_L + 4k_B T / R_L}{xq(I_p + I_D)}$$

### Structures for InGaAs APDs:-

Separate absorption and multiplication (SAM) APD

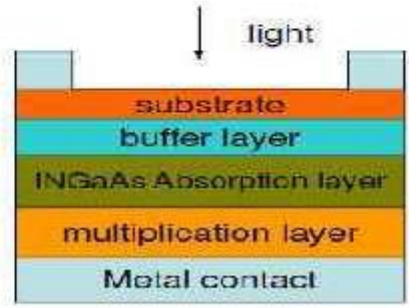

InGaAs APD superlattice structure (The multiplication region is composed of several layers of InAlGaAs quantum wells separated by InAlAs barrier layers).

## Fiber Optic System Design:-

There are many factors that must be considered to ensure that enough light reaches the receiver. Without the right amount of light, the entire system will not operate properly.

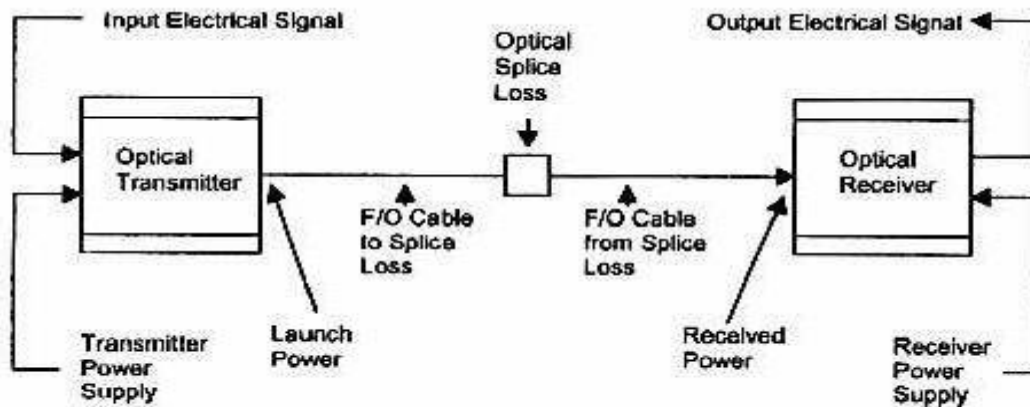

Figure 12, Important Parameters to Consider When Specifying F/O Systems

## Fiber Optic System Design- Step-by-Step:-

Select the most appropriate optical transmitter and receiver combination based upon the signal to be transmitted

Determine the operating power available (AC, DC, etc.).

Determine the special modifications (if any) necessary (Impedances, bandwidths, connectors, fiber size, etc.).

Carry out system link power budget.

Carry out system rise time budget (I.e. bandwidth budget).

If it is discovered that the fiber bandwidth is inadequate for transmitting the required signal over the necessary distance, then either select a different transmitter/receiver (wavelength) combination, or consider the use of a lower loss premium fiber

## Link Power Budget:-

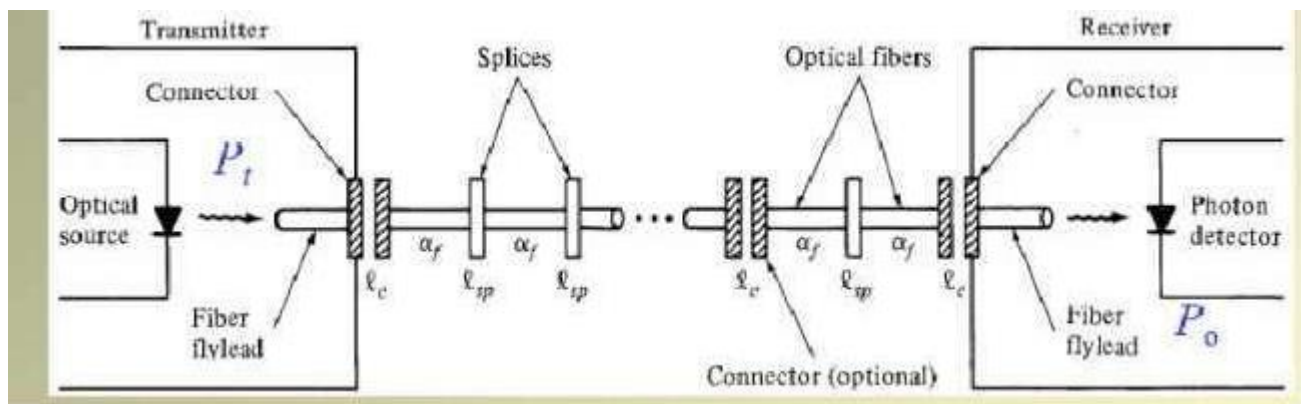

$$\text{Total loss } LT = \alpha_f L + \ell_c + \ell_{sp}$$

$$P_t - P_o = LT + SM$$

$P_o$  = Receiver sensitivity (i.e. minimum power requirement)

$SM$  = System margin (to ensure that small variation the system operating

parameters do not result in an unacceptable decrease in system performance)

### Link Power Budget - Example 1:-

Parameters	Value	dB
<ul style="list-style-type: none"> <li>▪ <i>Transmitter</i> <ul style="list-style-type: none"> <li>▪ Average transmitted power</li> <li>▪ Fibre coupling losses</li> </ul> </li> <li>▪ <i>Channel</i> <ul style="list-style-type: none"> <li>▪ Fibre loss</li> <li>▪ Splitting losses</li> <li>▪ Splice &amp; Connector losses</li> <li>▪ Fibre dispersion &amp; nonlinearity</li> </ul> </li> <li>▪ <i>Receiver</i> <ul style="list-style-type: none"> <li>▪ Signal power at the receiver</li> <li>▪ Receiver sensitivity</li> </ul> </li> </ul>	<p>3 mW</p> <p>All losses</p>	<p>4.8 dBm</p> <p>-3.7 dB</p> <p>-15.7 dB</p> <p>-10 dB</p> <p>-0.79 dB</p> <p>0 dB</p> <p>-26.79 dBm</p> <p>-31 dBm</p>
System Margin (-20 dBm -(-30 dBm))		+4.1 dB

### Link Power Budget - Example 2:-

**Transmitter**

- Data rate – 500 Mb/s
- Source Laser @ 1300 nm
- Coupling power = 2 mW (3 dBm) into a 10 um fibre.

**Channel**

- Mono mode fibre of length 60 km and a loss of 0.3 dB/km
- Connector loss = 1 dB/connector
- Splicing every 5 km with a loss = 0.5 dB /splice

**Receiver:**

- PIN @ 1300 nm
- BER =  $10^{-9}$

**System margin = ?**

### Link Power Budget - Example 2 contd.:-

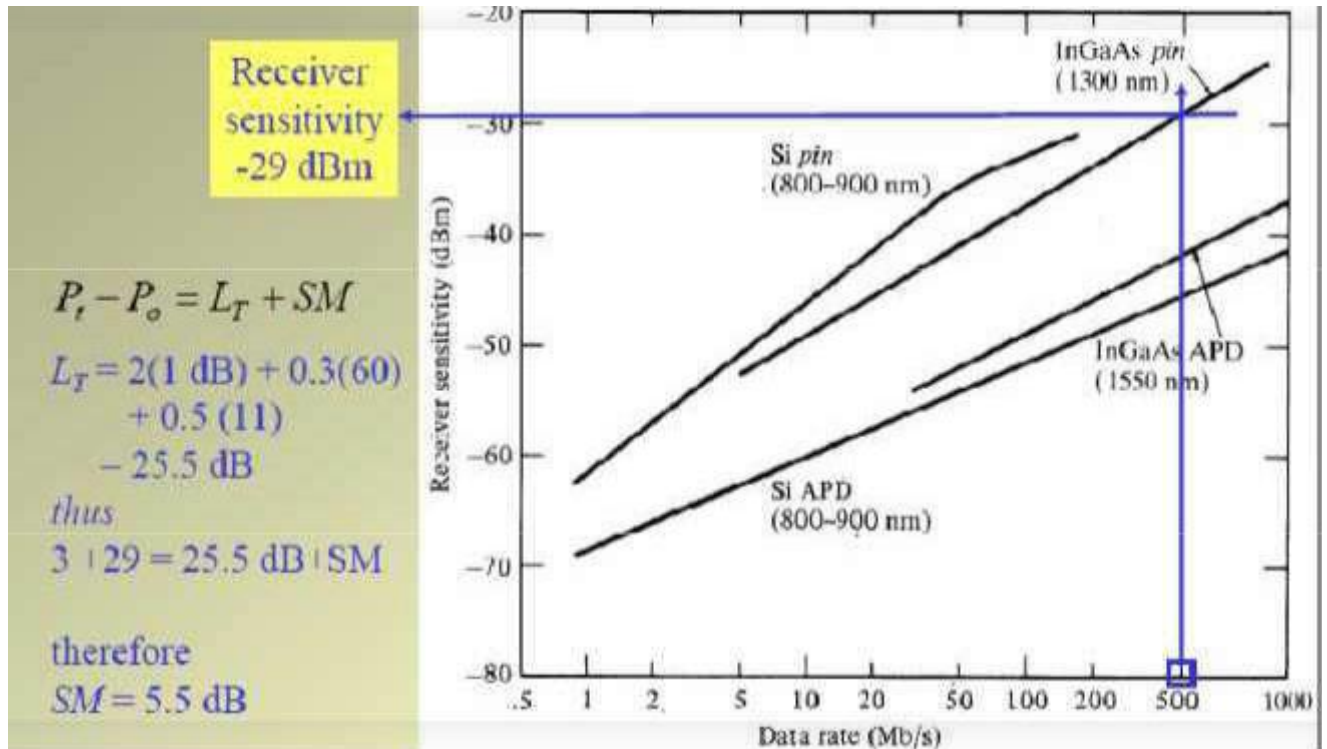

### Link-Power Budget - Example 3:-

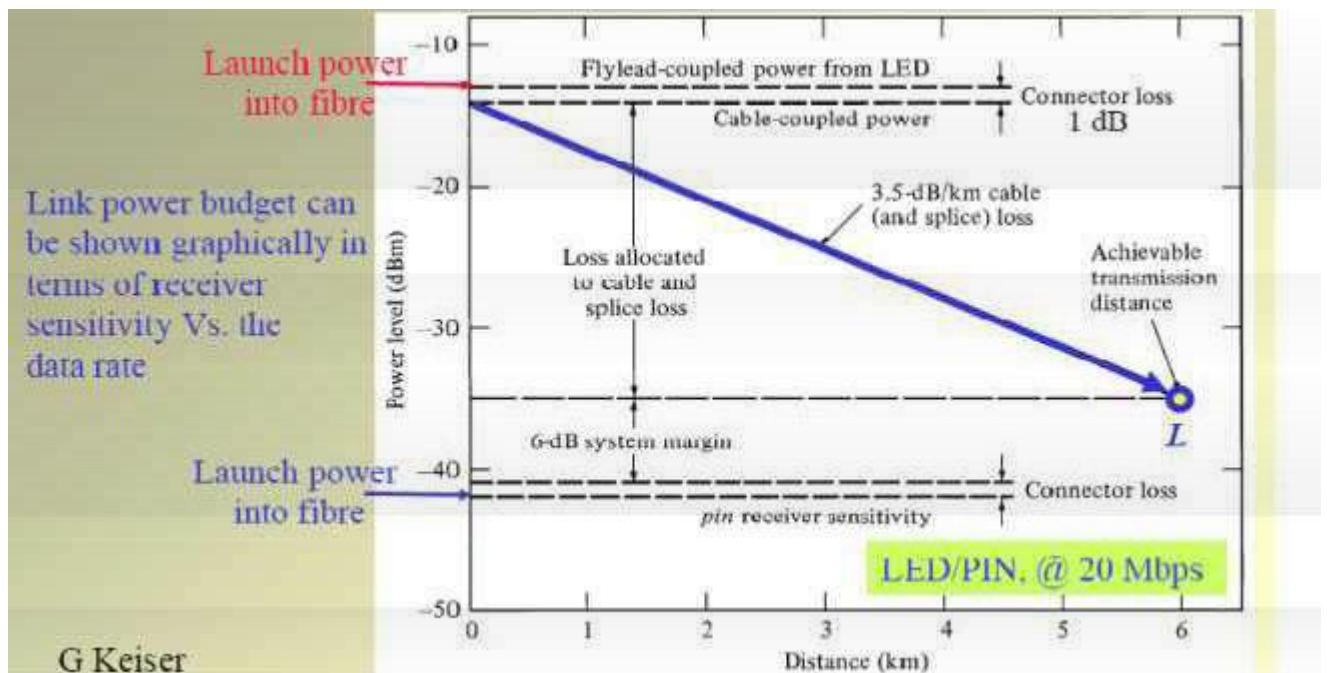

Dispersion -equalisation penalty is given as:

$$D_L = 2(2\sigma B_1 \sqrt{2})^4 \quad (\text{dB})$$

Where  $B_1$  is the bit rate,  $\sigma$  is the rms pulse width.

Therefore, the total channel loss is given as:

$$\text{Total loss } L_T = \alpha_f L + l_c + l_{sp} + D_L \quad (\text{dB})$$

$D_L$  is only significant in wideband multi-mode fibre systems

### Rise Time Budget:-

The system design must also take into account the temporal response of the system components. The total loss  $L_T$  (given in the power budget section) is determined in the absence of the any pulse broadening due to dispersion.

Finite bandwidth of the system (transmitter, channel, receiver) may results in pulse spreading (i.e. intersymbol interference), giving a **reduction in the receiver sensitivity**. I.e. worsening of BER or SNR

The additional loss penalty is known as **dispersion equalisation or ISI penalty**.

The total system rise time

$$t_{sys} = \left( \sum_{i=1}^N t_i^2 \right)^{0.5}$$

$$t_{sys} = \left( t_s^2 + t_{inter}^2 + t_{intra}^2 + t_d^2 \right)^{0.5}$$

↑ Source    
 ↑ Fibre intermodal    
 ↑ Fibre intramodal    
 ↑ Detector

Note - 3 dB bandwidth of a simple low pass RC filter is given as:

$$B = \frac{1}{2\pi RC}$$

With a step input voltage into the RC filter, the rise time of the output voltage is:

$$t_r = 2.2B = \frac{0.35}{B}$$

For a fibre optic link:

$$t_{sys} = t_r = \frac{0.35}{B}$$

For RZ data format

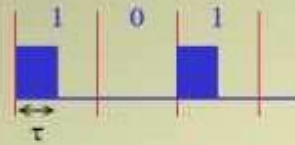

$$\text{Bit rate } R = B = 1/\tau$$

$$B_{RZ} = \frac{0.35}{t_{sys}}$$

For NRZ data format

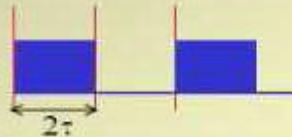

$$\text{Bit rate } R = B = 1/2\tau$$

$$B_{NRZ} = \frac{0.75}{t_{sys}}$$

### Transmission Distance -1st window:-

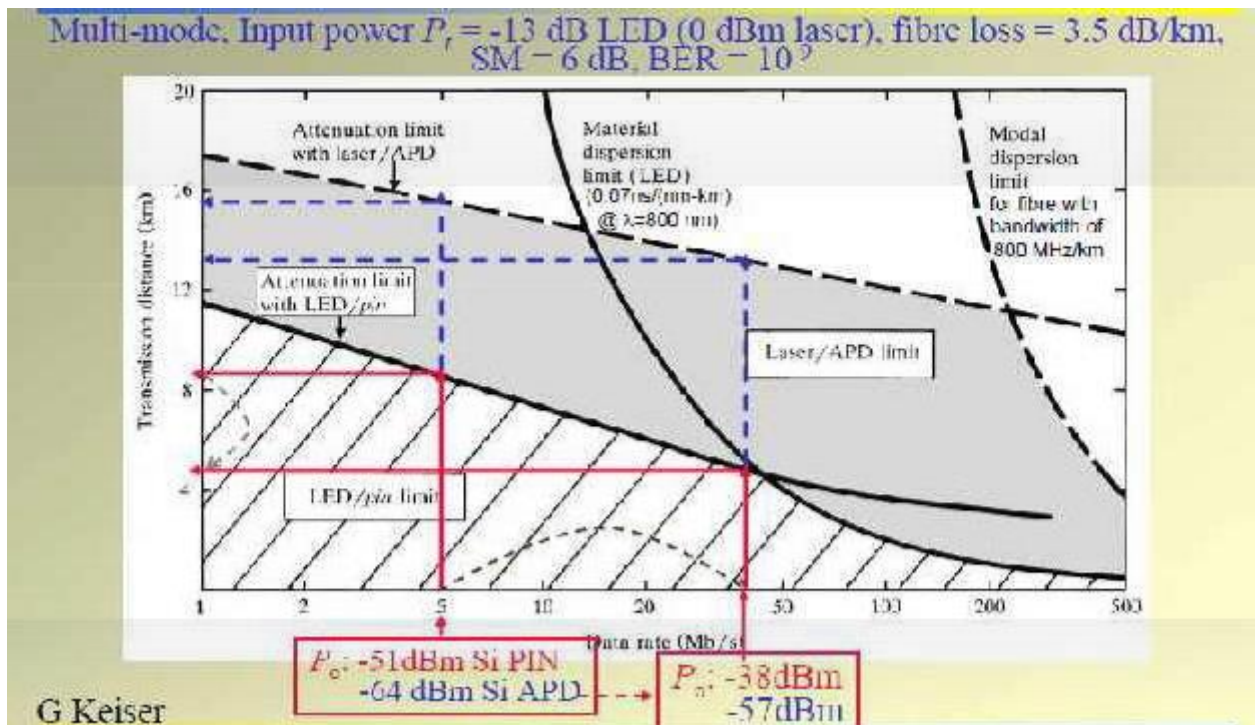

### Transmission Distance -3rd window:-

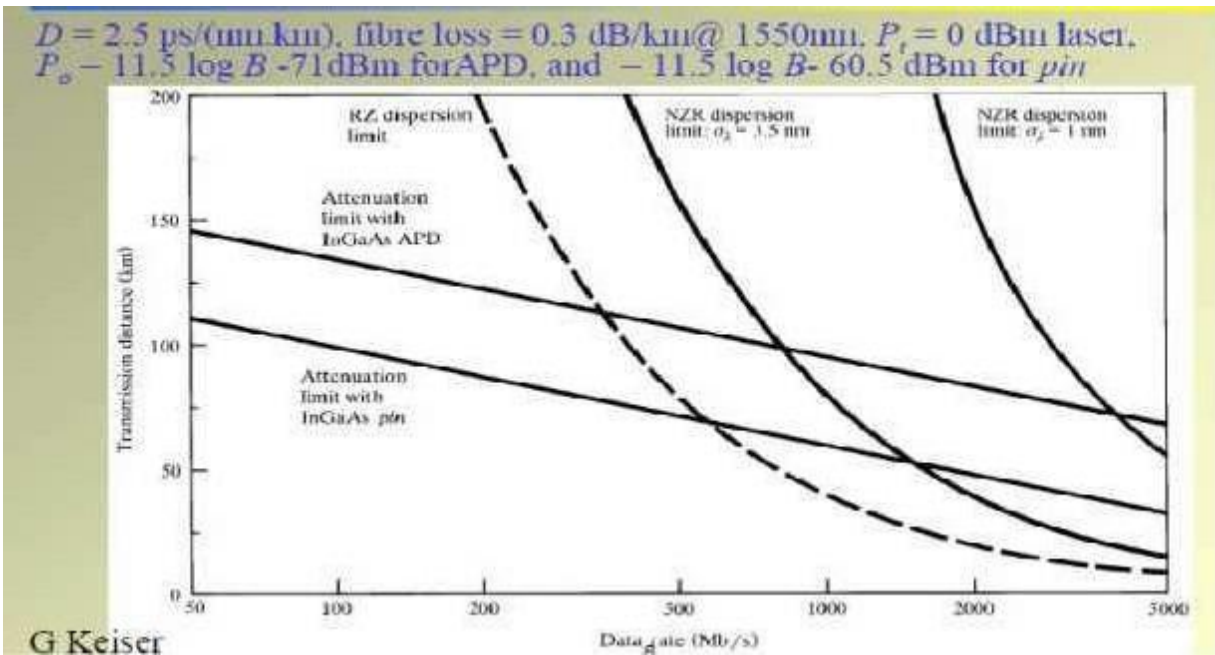

### Analogue System:-

The system must have sufficient bandwidth to pass the HIGHEST FREQUENCIES. Link Power budget is the same as in digital systems Rise Time budget is also the same, except for the system bandwidth which is defined as:

$$B_{sys} = \frac{0.35}{T_{sys}}$$