

**ELECTRICAL MACHINES
II
(EE501)**

Online Courseware (OCW)

B.TECH (3rd YEAR – 5th SEM)

(2020-21)

Prepared by: Mr. AMIT DEBNATH

Department of Electrical Engineering



Guru Nanak Institute of Technology

(Affiliated to MAKUT, West Bengal, Approved by AICTE - Accredited by NAAC - 'A+' Grade)
157/F Nilgunj road, Panihati, Kolkata-700114, West Bengal

Course Code: EE 501
Contact: 3L: 0T: 0P
Total Contact Hours: 36
Credit: 3

Prerequisites: Knowledge of Physics up to B. Tech. 1st year Physics-I course and Electrical Machines – I.

Course Outcome: On completion of the course students will be able to

- CO1.** Describe the concept of rotating magnetic fields.
- CO2.** Demonstrate the operation of AC Machines.
- CO3.** Understand the principle of operation and know performance of synchronous machine and fractional kW motors.
- CO4.** Analyse performance characteristics of ac machines.

Course Content

MODULE – I: Synchronous Machines	(21L)
Construction of 3-phase Synchronous Machines, Description of salient & non-salient rotor, Advantages of Stationary armature and Rotating field system, Name plate rating.	1L
Methods of excitation systems: Static excitation, Brushless excitation, DC generator. Armature reaction at various p.f, concept of Synchronous reactance.	1L 2L
Phasor diagrams of alternator at lagging, leading and unity p.f. loads.	1L
Voltage regulation of alternator by synchronous impedance method, Solution of problems.	2L
Open circuit characteristics, Short circuit characteristics of alternator and determination of synchronous reactance.	1L
Theory for salient pole machine, Two reaction theory, phasor diagram at different loads.	2L
Power angle characteristics of Synchronous machines, Solution of problems.	1L
Short circuit ratio (SCR) – concept and significance.	1L
Method of control of Active & Reactive Power of an alternator. Reasons and advantages of Parallel operation.	1L 1L
Synchronization of two or more alternators: Three lamps method, Synchroscope.	1L
Parallel operation of (i) an alternator and infinite bus and (ii) Between two alternators and Load sharing between them. Solution of problems.	2L
Methods of starting of Three-Phase Synchronous Motor: by auxiliary motor and Damper winding.	1L
Effect of variation of excitation at infinite bus (over and under excitation) – V curves and inverted V curves.	1L
Hunting and its prevention.	1L
Applications of synchronous motor, Synchronous condenser.	1L
MODULE – II: Single-Phase Induction Motor	(11L)
Construction, Concept of Pulsating Torque, Double-revolving field theory.	2L
Development of equivalent circuit, Determination of equivalent circuit parameters, Solution of problems.	2L

Methods of starting using auxiliary winding, Selection of capacitor value during starting and running, Solution of problems. 2L
 Speed-Torque characteristics, Phasor diagram, Condition of Maximum torque. 2L
 Constructional features and performance characteristics of Universal Series Motors, Compensated and uncompensated motors. 2L
 Testing of Single phase motors and Applications. 1L

MODULE – III: Special Machines

(4L)

Principle and construction of switched Reluctance motor, Permanent magnet machines, Brushless DC machines, Hysteresis motor, Stepper Motor. 2L
 Construction and Operational characteristics of Induction generator and Linear Induction motor. 2L

Text Books:

1. Electrical Machines, Nagrath & Kothary, TMH
2. The performance and design of Alternating Current machines, M.G.Say, C.B.S Publishers & Distributors
3. Electrical Machinery, P.S. Bhimra, Khanna Publishers.
4. Electrical Machines, Ashfaq Husain, Dhanpat Rai & Co.
5. Electrical Machines, S.K.Bhattacharya, T.M.H Publishing Co. Ltd.

Reference Books:

1. Electrical Machines, Theory & Applications, M.N. Bandyopadhyay, PHI
2. Electrical Technology, H.Cotton, C.B.S. Publisher New Delhi
3. Electric Machinery & Transformes, Irving L. Kosow, PHI
4. Electric Machinery, A.E.Fitzgerald, Charles Kingsley, Jr. & Stephen D. Umans, 6thEdition, Tata McGraw Hill Edition.
5. Problems in Electrical Engineering, Parker smith, 9thEdition, CBS publishers & distributors.

CO-PO-PSO Mapping:

CO	POs												PSO		
	1	2	3	4	5	6	7	8	9	10	11	12	1	2	3
CO1	3	3	1	1	-	-	-	2	1	2	-	2	2	-	1
CO2	3	2	2	1		-		1	-	1	-	2	2	2	1
CO3	3	3	1	2	-	1	-	1	-	1	2	2	-	2	1
CO4	3	2	-	-	-		-	2	-		1	2	2	1	-
Avg	3	2.5	1.3	1.3	-	1	-	1.5	1	1.3	1.5	2	2	1.6	1

TOPIC:

**□ INTRODUCTION TO
SYNCHRONOUS MACHINES**

**Lecture:
01**



SYNCHRONOUS MACHINES

INTRODUCTION

A synchronous machine is an ac rotating machine whose speed under steady state condition is proportional to the frequency of the current in its armature. The magnetic field created by the stator currents rotates at the synchronous speed, and that created by the field current on the rotor is rotating at the synchronous speed also, and a steady torque results. So, these machines are called synchronous machines because they operate at constant speeds and constant frequencies under steady state conditions. Synchronous machines are commonly used as generators especially for large power systems, such as turbine generators and hydroelectric generators in the grid power supply.

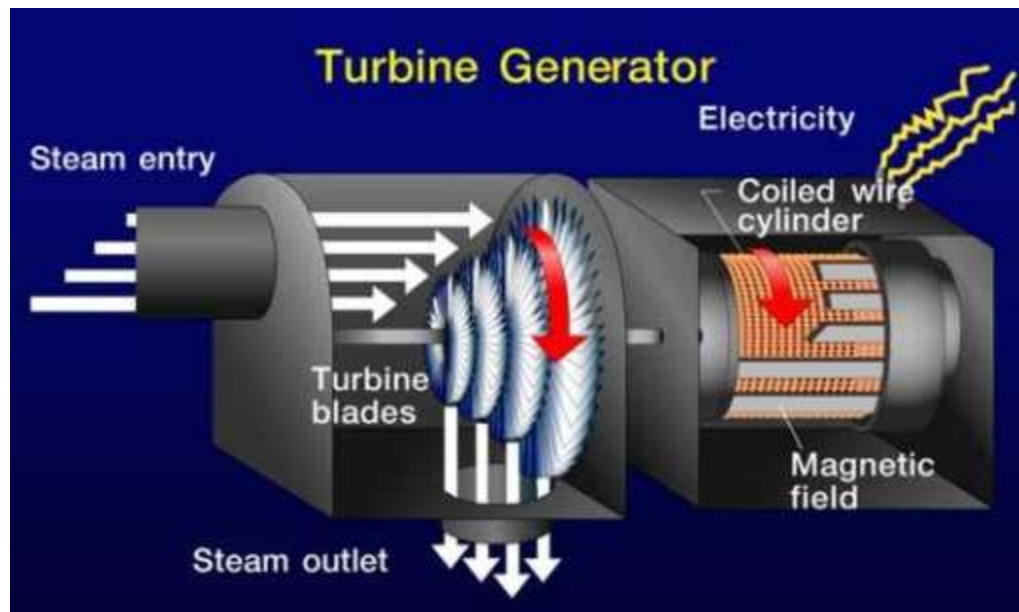

SYNCHRONOUS MACHINES

CONCEPT OF DC GENERATOR

A DC generator is an electrical machine whose main function is to convert mechanical energy into dc electricity. When conductor slashes magnetic flux, an emf will be generated based on the electromagnetic induction principle of Faraday's Laws. This electromotive force can cause a flow of current when the conductor circuit is closed.

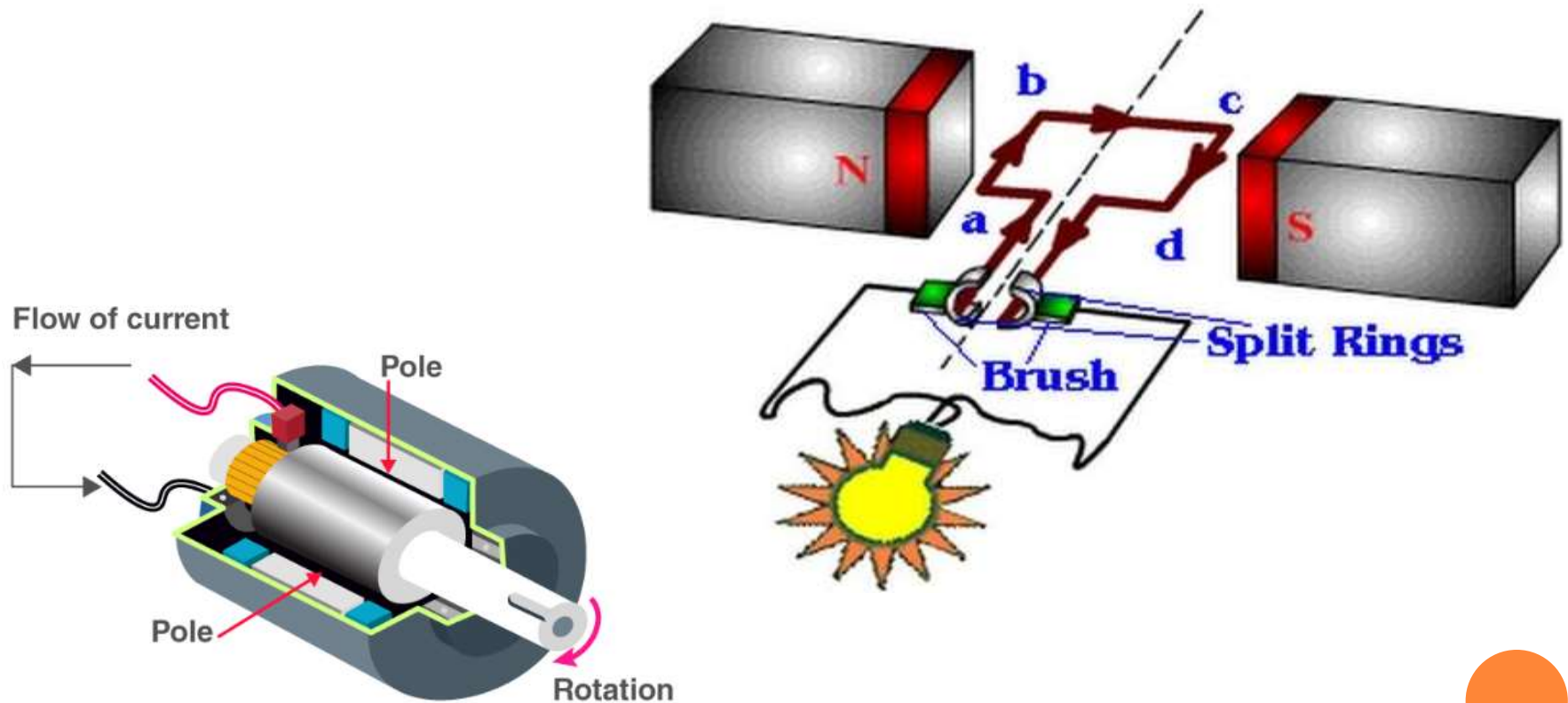

SYNCHRONOUS MACHINES

SYNCHRONOUS GENERATOR [ALTERNATOR] INTRODUCTION

Synchronous machines are principally used as alternating current generators. They supply the electric power used by all sectors of modern society. Synchronous machine is an important electromechanical energy converter. Synchronous generators usually operate in parallel forming a large power system supplying electrical power to consumers or loads. For these applications the synchronous generators are built in large units, their rating ranging from tens to hundreds of Megawatts. These synchronous machines can also be run as synchronous motors.

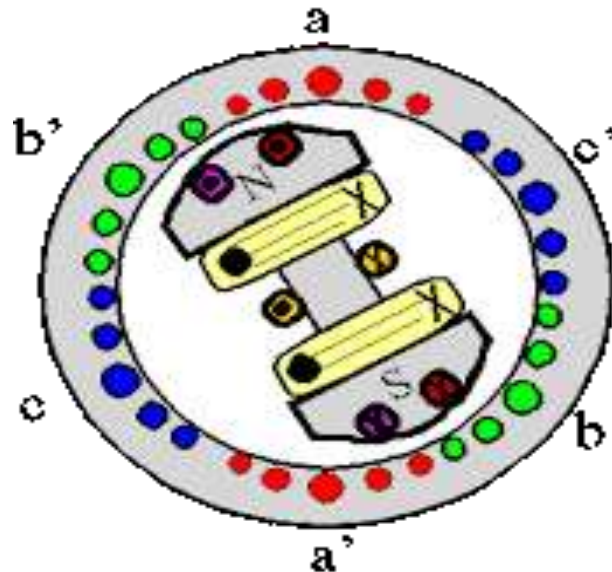

SYNCHRONOUS MACHINES

SYNCHRONOUS GENERATOR [ALTERNATOR] INTRODUCTION

Synchronous machines are AC machines that have a field circuit supplied by an external DC source. Synchronous machines are having two major parts namely stationary part stator and a rotating field system called rotor. In a synchronous generator, a DC current is applied to the rotor winding producing a rotor magnetic field. The rotor is then driven by external means producing a rotating magnetic field, which induces a 3-phase voltage within the stator winding. Field windings are the windings producing the main magnetic field (rotor windings for synchronous machines); armature windings are the windings where the main voltage is induced (stator windings for synchronous machines).

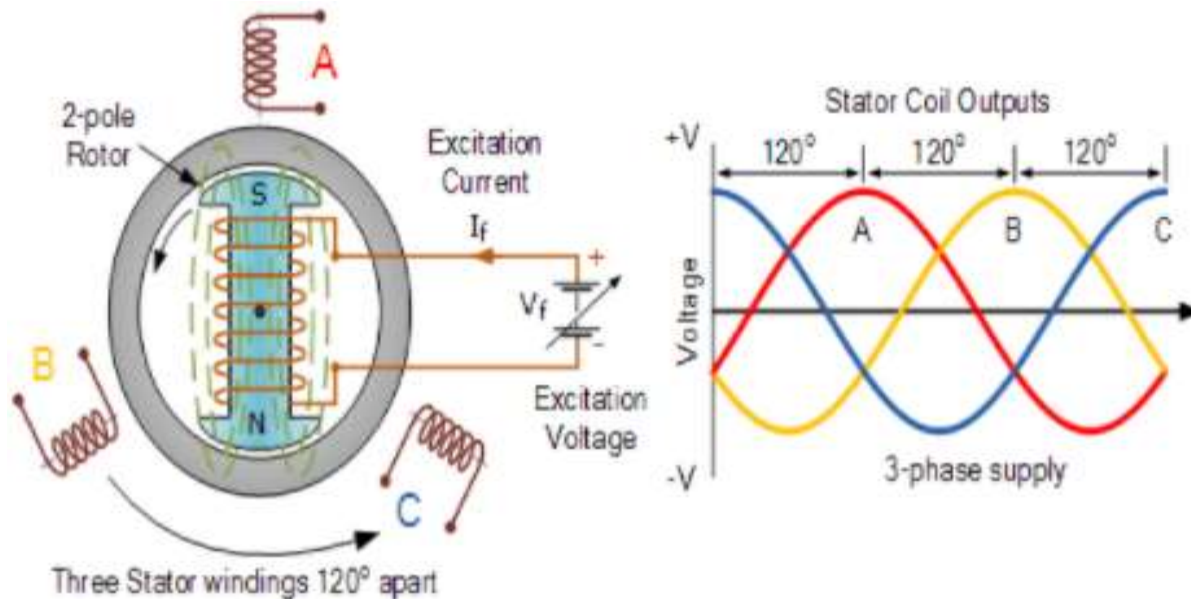

SYNCHRONOUS MACHINES

TYPES OF SYNCHRONOUS MACHINES

According to the arrangement of armature and field winding, the synchronous machines are classified as rotating armature type or rotating field type.

In rotating armature type the armature winding is on the rotor and the field winding is on the stator.

The generated emf or current is brought to the load via the slip rings. These type of generators are built only in small units.

In case of rotating field type generators field windings are on the rotor and the armature windings are on the stator. Here the field current is supplied through a pair of slip rings and the induced emf or current is supplied to the load via the stationary terminals.

Based on the type of the prime movers employed the synchronous generators are classified as

- 1. Hydro Generators**
- 2. Turbo Generators**
- 3. Engine driven Generators:**



TOPIC:

CONSTRUCTION OF 3-PHASE SYNCHRONOUS MACHINES

SALIENT & NON-SALIENT ROTOR

ADVANTAGES OF STATIONARY ARMATURE AND ROTATING FIELD SYSTEM

NAME PLATE RATING

**Lecture:
02**

SYNCHRONOUS MACHINES

Construction of a Synchronous Machine

Construction of a Synchronous Machine, i.e. alternator or motor consists of two main parts, namely the stator and the rotor. The stator is the stationary part of the machine. It carries the armature winding in which the voltage is generated. The output of the machine is taken from the stator. The rotor is the rotating part of the machine. The rotor produces the main field flux.

The synchronous generator or alternator is an electrical machine that converts the mechanical power from a prime mover into an AC electrical power at a particular voltage and frequency. The synchronous motor always runs at a constant speed called synchronous speed.

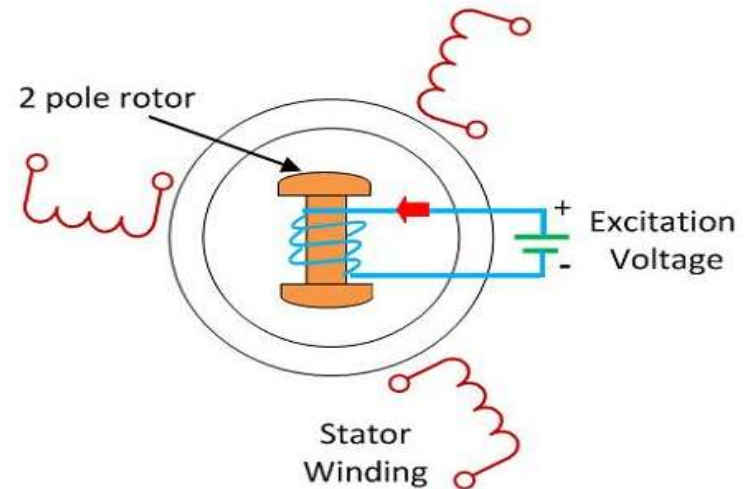

Synchronous motor and induction motor are the most widely used types of AC motor. Construction of a synchronous motor is similar to an alternator (AC generator). A same synchronous machine can be used as a synchronous motor or as an alternator. Synchronous motors are available in a wide range, generally rated between 150kW to 15MW with speeds ranging from 150 to 1800 rpm.

SYNCHRONOUS MACHINES

Construction of a Synchronous Machine

The important parts of the Synchronous Machine are given below.

1. Stator
2. Rotor
3. Miscellaneous

Stator Construction

The stationary part of the machine is called Stator. It includes various parts like stator frame, stator core, stator windings and cooling arrangement.

Stator Frame

It is the outer body of the machine made of cast iron, and it protects the inner parts of the machine.

Stator Core

The stator core is made of silicon steel material. It is made from a number of stamps which are insulated from each other. Its function is to provide an easy path for the magnetic lines of force and accommodate the stator winding.

Stator Winding

Slots are cut on the inner periphery of the stator core in which 3 phase or 1 phase winding is placed. Enameled copper is used as winding material. The winding is star connected. The winding of each phase is distributed over several slots. When the current flows in a distributed winding it produces an essentially sinusoidal space distribution of EMF.



SYNCHRONOUS MACHINES

Construction of a Synchronous Machine

Rotor Construction

The rotating part of the machine is called Rotor. There are two types of rotor construction, namely the salient pole type and the cylindrical rotor type.

Salient Pole Rotor

The term salient means projecting. Thus, a salient pole rotor consists of poles projecting out from the surface of the rotor core. The end view of a typical 6 pole salient pole rotor is shown below in the figure.

Since the rotor is subjected to changing magnetic fields, it is made of steel laminations to reduce eddy current losses. Poles of identical dimensions are assembled by stacking laminations to the required length. A salient pole synchronous machine has a non uniform air gap. The air gap is minimized under the pole centers and it is maximum in between the poles.

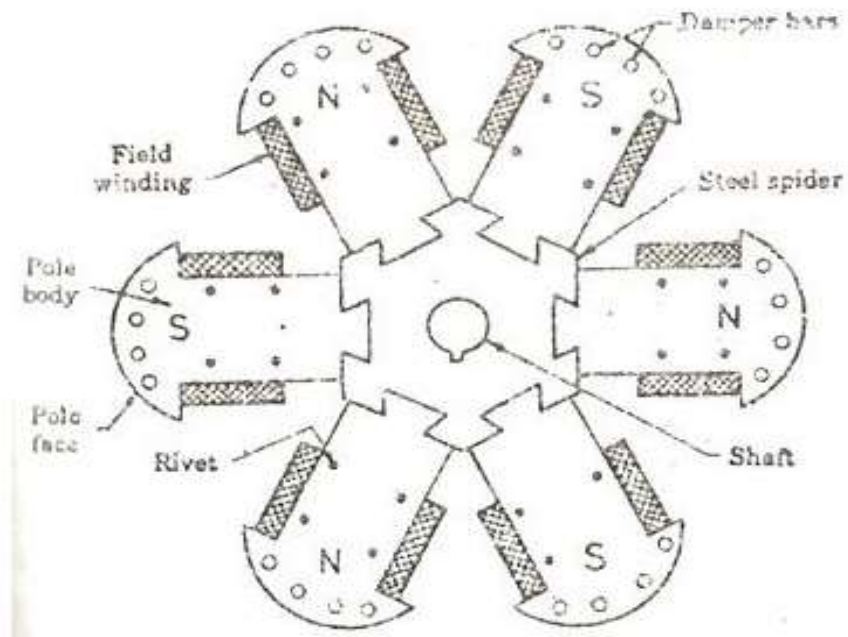

SYNCHRONOUS MACHINES

Construction of a Synchronous Machine

They are constructed for the medium and low speeds as they have a large number of poles. A salient pole generator has a large diameter. The salient pole rotor has the following important parts.

Spider

It is made of cast iron to provide an easy path for the magnetic flux. It is keyed to the shaft and at the outer surface, pole core and pole shoe are keyed to it.

Pole Core and Pole Shoe

It is made of laminated sheet steel material. Pole core provides least reluctance path for the magnetic field and pole shoe distributes the field over the whole periphery uniformly to produce a sinusoidal wave.

Field Winding or Exciting Winding

It is wound on the former and then placed around the pole core. DC supply is given to it through slip rings. When direct current flow through the field winding, it produces the required magnetic field.

Damper Winding

At the outermost periphery, holes are provided in which copper bars are inserted and short-circuited at both the sides by rings forming Damper winding.



SYNCHRONOUS MACHINES

Construction of a Synchronous Machine

Non- Salient Pole Rotor or Cylindrical Rotor

In this type of rotor, there are no projected poles, but the poles are formed by the current flowing through the rotor exciting winding. Cylindrical rotors are made from solid forgings of high-grade nickel chrome molybdenum steel. It has a comparatively small diameter and long axial length.

They are useful in high-speed machines. The cylindrical rotor type alternator has two or four poles on the rotor. Such a construction provides a greater mechanical strength and permits more accurate dynamic balancing. The smooth rotor of the machine makes less windage losses and the operation is less noisy because of the uniform air gap.

The figure below shows the end view of the 2 pole and 4 pole cylindrical rotors.

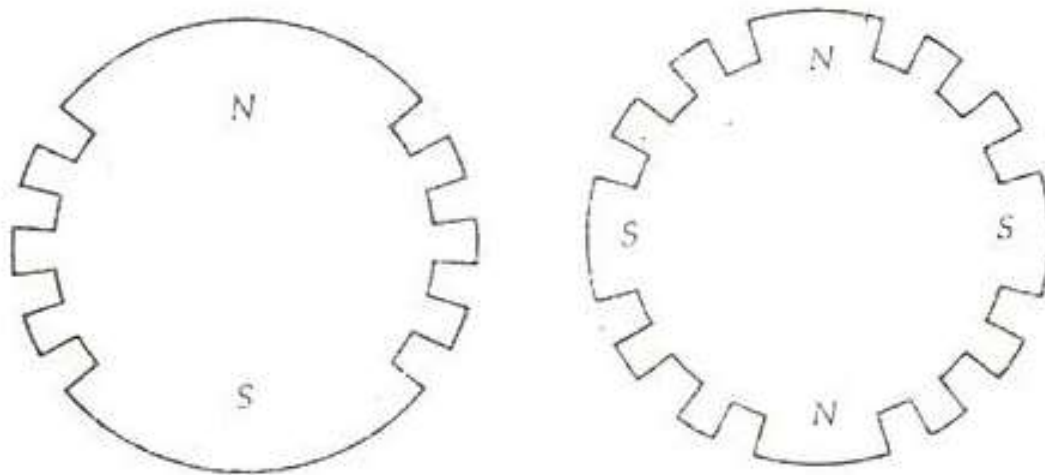

SYNCHRONOUS MACHINES

Construction of a Synchronous Machine

Non- Salient Pole Rotor or Cylindrical Rotor

They are driven by steam or gas turbines. Cylindrical synchronous rotor synchronous generators are called turbo alternators and turbo generators. The machines are built in a number of rating from 10 MVA to over 1500 MVA. The biggest size used in India has a rating of 500 MVA installed in the super thermal power plant.

Non salient pole type rotors have the following parts. They are as follows

Rotor Core

The rotor core is made of silicon steel stampings. It is placed on the shaft. At the outer periphery, slots are cut in which exciting coils are placed.

Rotor Winding or Exciting Winding

It is placed on the rotor slots, and current is passed through the winding in such a way that the poles are formed according to the requirement.

Slip Rings

Slip rings provide DC supply to the rotor windings.



SYNCHRONOUS MACHINES

Construction of a Synchronous Machine

Miscellaneous Parts

The miscellaneous parts are given below.

Brushes

Brushes are made of carbon, and they slip over the slip rings. A DC supply is given to the brushes. Current flows from the brushes to the slip rings and then to the exciting windings.

Bearings

Bearings are provided between the shaft and the outer stationary body to reduce the friction. They are made of high carbon steel.

Shaft

The shaft is made of mild steel. Mechanical power is taken or given to the machine through the shaft



SYNCHRONOUS MACHINES

Advantages of stationary armature and rotating field system

The field winding of an alternator is placed on the Rotor and is connected to dc supply through two slip rings. The three phase armature winding is Placed on the stator. This arrangement has the following advantages

- (i) The stationary armature coils can be insulated easily.
- (ii) Higher peripheral speed can be achieved in the rotor.
- (iii) Cooling of the winding is more efficient.
- (iv) Only two slip rings are required to give DC supply to the field system
- (v) Output current can be easily supplied to the load circuit. Slip-rings and brushes are not necessary.

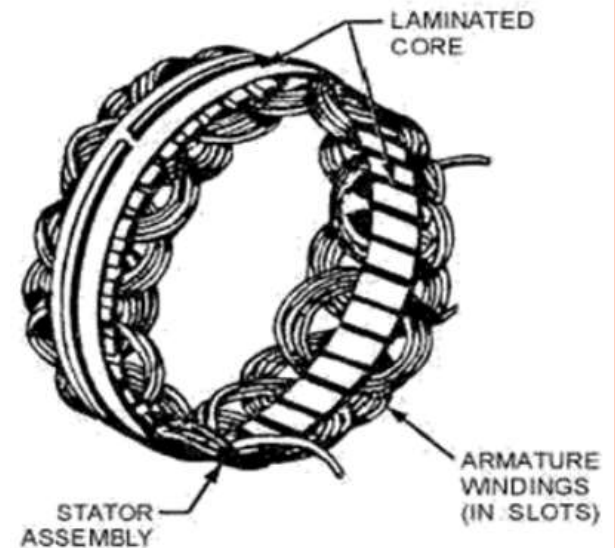
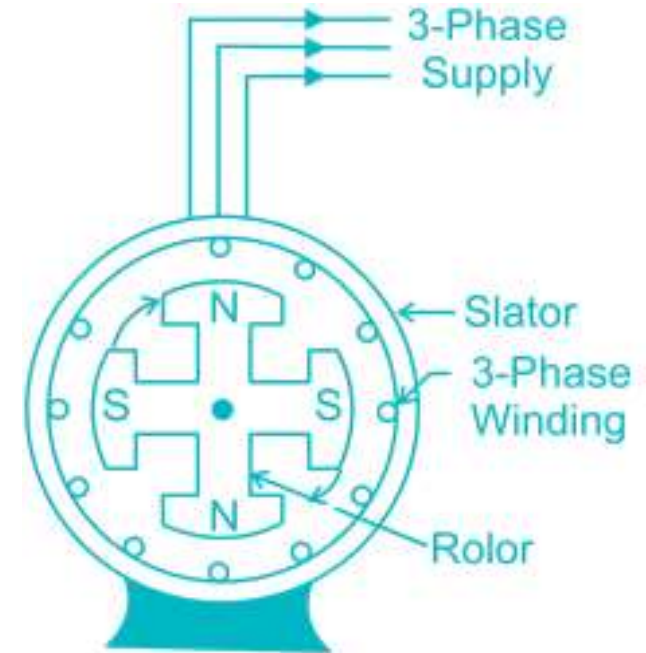

SYNCHRONOUS MACHINES

Synchronous Machine Nameplate Details

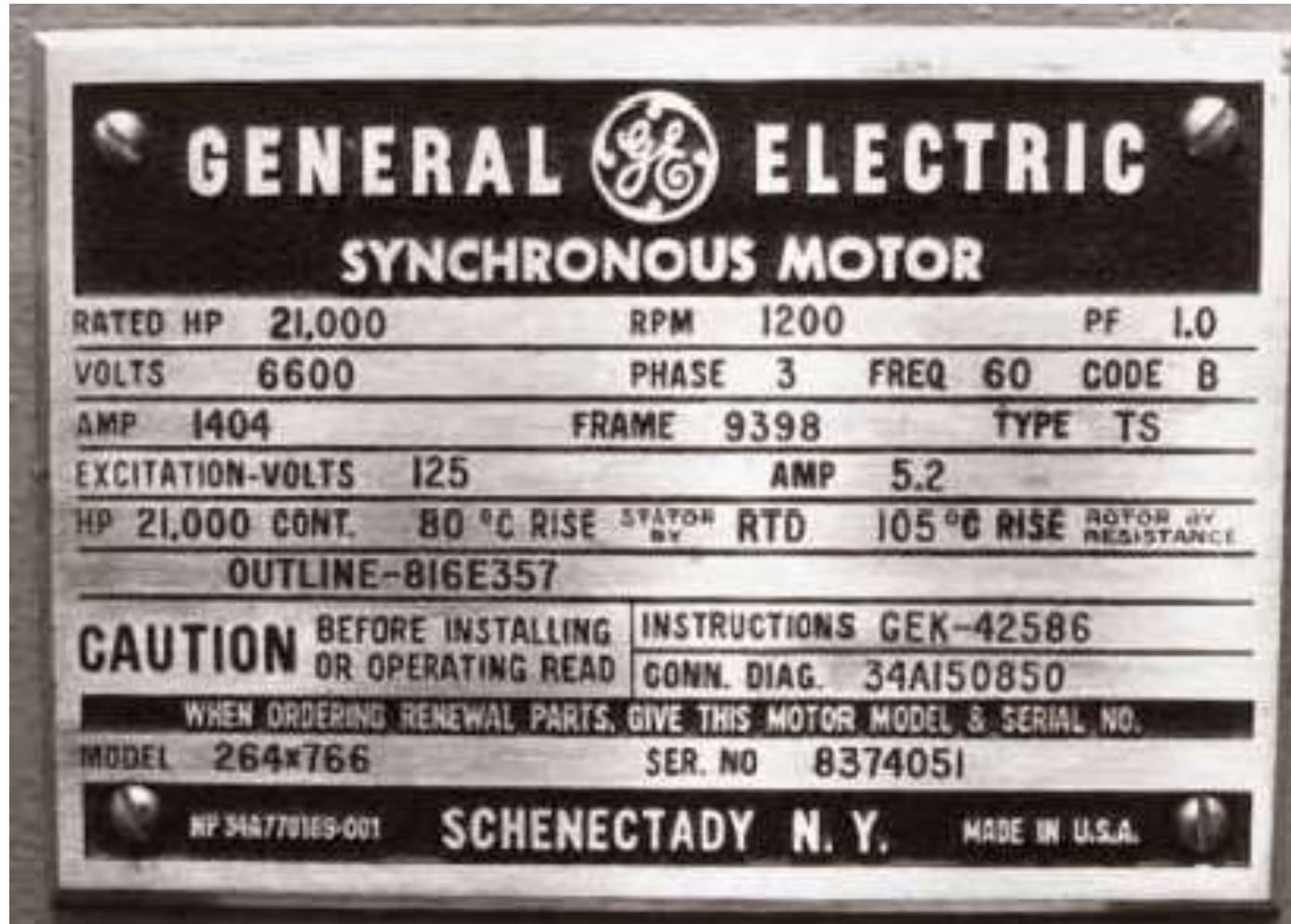

TOPIC:

**□ METHODS OF EXCITATION
SYSTEMS**

**Lecture:
03**



SYNCHRONOUS MACHINES

Methods of excitation systems

The system which is used for providing the necessary field current to the rotor winding of the synchronous machine, such type of system is called an excitation system. In other words, excitation system is defined as the system which is used for the production of the flux by passing current in the field winding. The main requirement of an excitation system is reliability under all conditions of service, a simplicity of control, ease of maintenance, stability and fast transient response.

The amount of excitation required depends on the load current, load power factor and speed of the machine. The more excitation is needed in the system when the load current is large, the speed is less, and the power factor of the system becomes lagging.

The excitation system is the single unit in which the each alternator has its exciter in the form of generator. The centralized excitation system has two or more exciter which feeds the bus-bar. The centralized system is very cheap, but the fault in the system adversely affects the alternators in the power plant



SYNCHRONOUS MACHINES

Methods of excitation systems

Types of Excitation System

The excitation system is mainly classified into three types.

They are

1. DC Excitation System
2. AC Excitation System
 - i. Rotor Excitation System
 - ii. Brushless Excitation System
3. Static Excitation System



SYNCHRONOUS MACHINES

Methods of excitation systems

1. DC Excitation System

The DC excitation system has two exciters – the main exciter and a pilot exciter. The exciter output is adjusted by an automatic voltage regulator (AVR) for controlling the output terminal voltage of the alternator. The current transformer input to the AVR ensures limiting of the alternator current during a fault.

When the field breaker is open, the field discharge resistor is connected across the field winding so as to dissipate the stored energy in the field winding which is highly inductive.

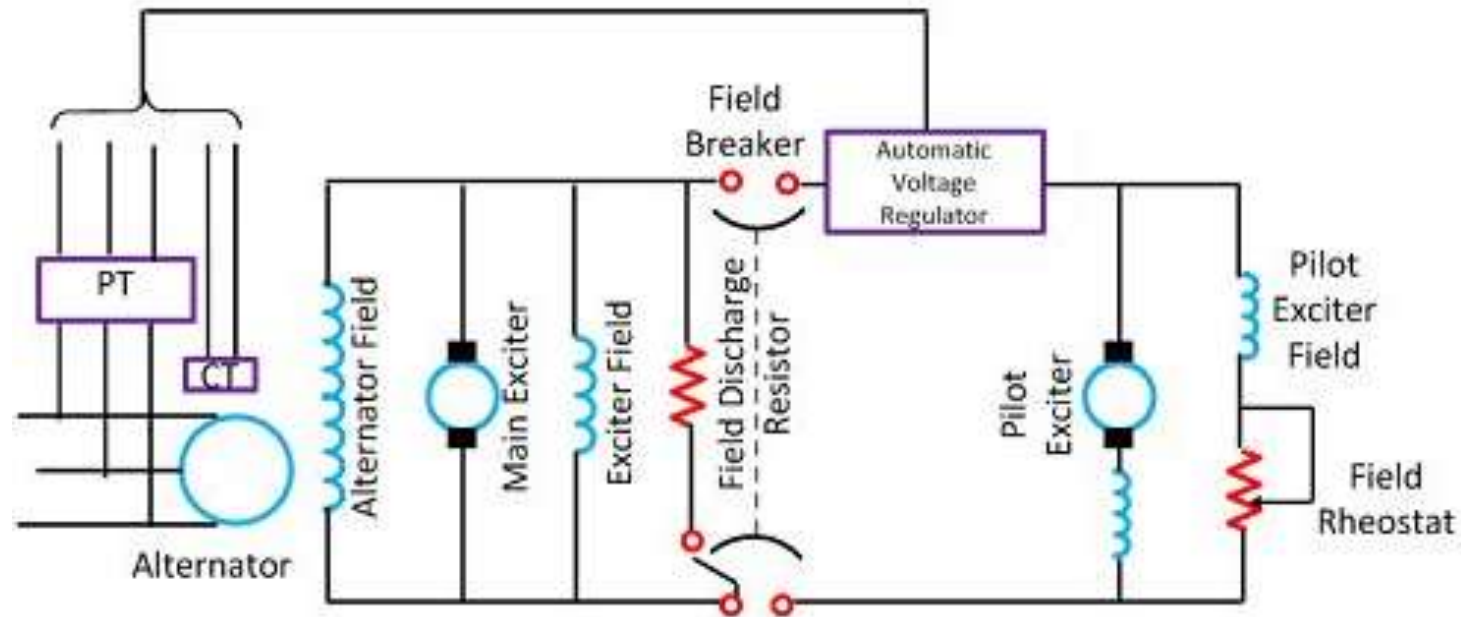

SYNCHRONOUS MACHINES

Methods of excitation systems

1. DC Excitation System

The main and the pilot exciters can be driven either by the main shaft or separately driven by the motor. Direct driven exciters are usually preferred as these preserve the unit system of operation, and the excitation is not excited by external disturbances.

The voltage rating of the main exciter is about 400 V, and its capacity is about 0.5% of the capacity of the alternator. Troubles in the exciters of turbo alternator are quite frequent because of their high speed and as such separate motor driven exciters are provided as standby exciter.



SYNCHRONOUS MACHINES

Methods of excitation systems

2. Brushless Excitation System

The rotating portion being enclosed by a dashed line rectangle. The brushless excitation system consists an alternator, rectifier, main exciter and a permanent magnet generator alternator. The main and the pilot exciter are driven by the main shaft. The main exciter has a stationary field and a rotating armature directly connected, through the silicon rectifiers to the field of the main alternators.

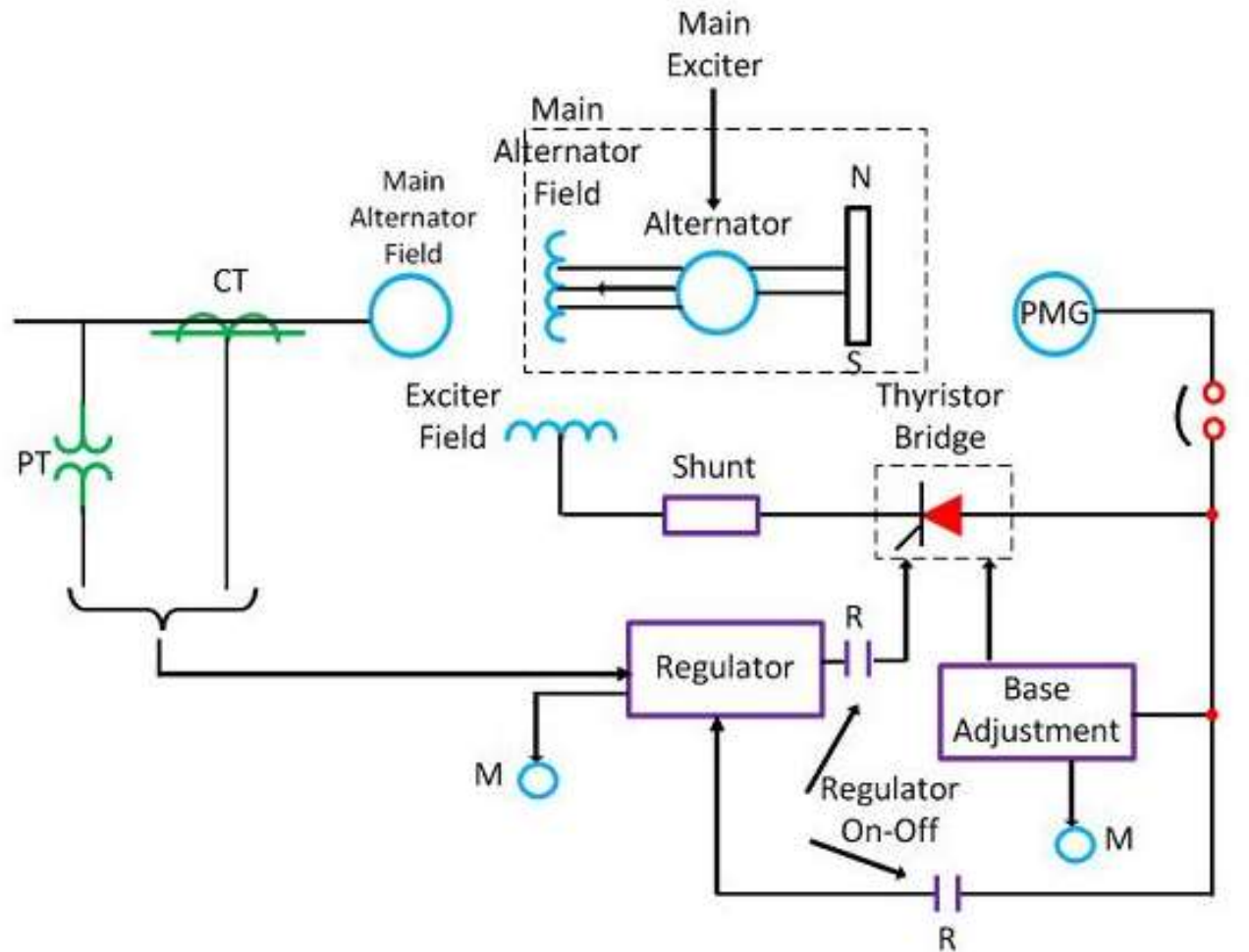

SYNCHRONOUS MACHINES

Methods of excitation systems

2. Brushless Excitation System

The pilot exciter is the shaft driven permanent magnet generator having rotating permanent magnets attached to the shaft and a three phase stationary armature, which feeds the main exciter field through silicon rectifiers, in the field of the main alternator. The pilot exciter is a shaft driven permanent magnetic generator having rotating permanent magnets attached to the shaft and a 3-phase stationary armature, which feeds the main's exciter through 3-phase full wave phase controlled thyristor's bridges.

The system eliminates the use of a commutator, collector and brushes have a short time constant and a response time of fewer than 0.1 seconds. The short time constant has the advantage in improved small signal dynamic performance and facilitates the application of supplementary power system stabilizing signals.



SYNCHRONOUS MACHINES

Methods of excitation systems

3. Static Excitation System

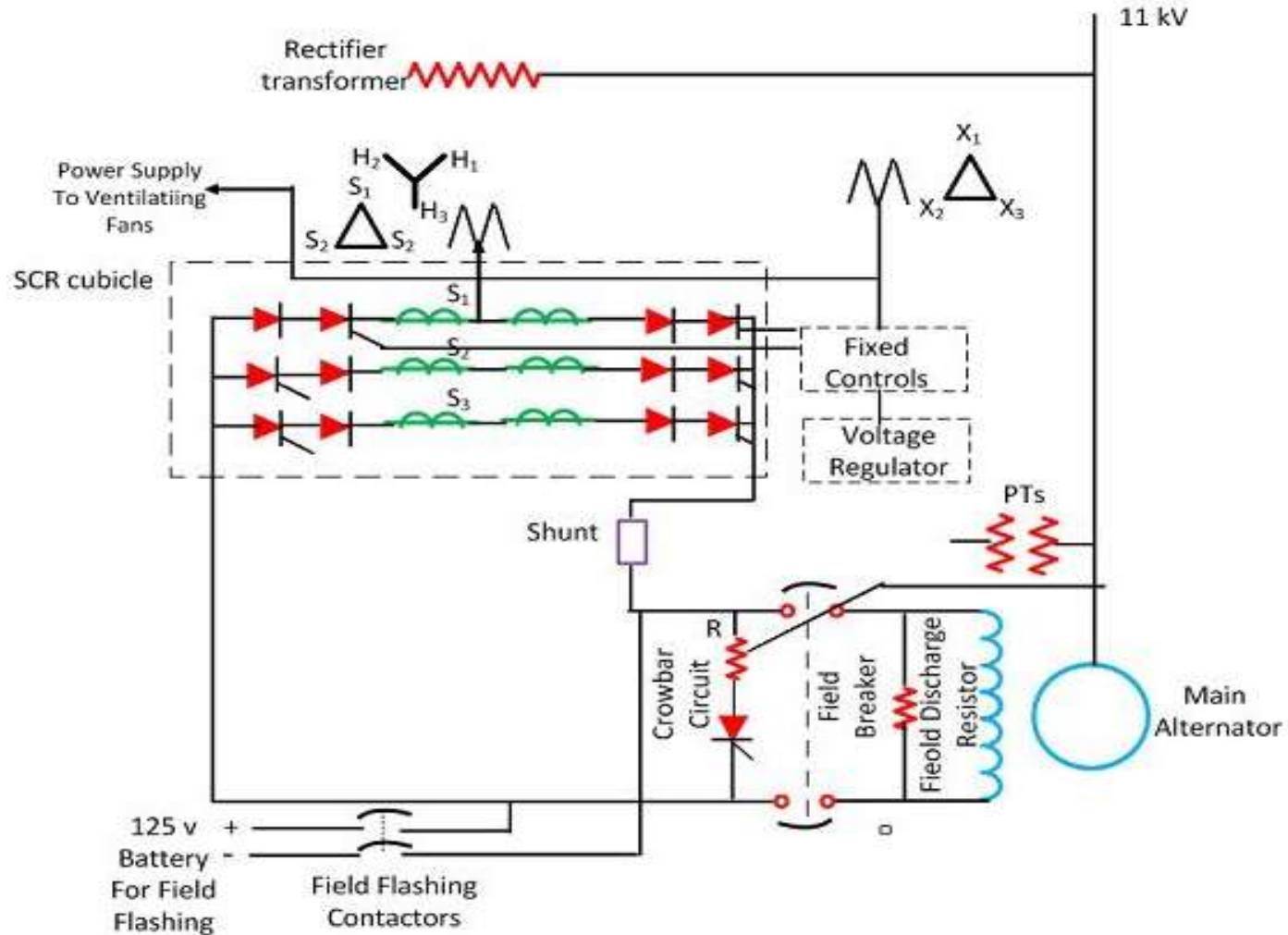

SYNCHRONOUS MACHINES

Methods of excitation systems

3. Static Excitation System

In this system, the supply is taken from the alternator itself through a 3-phase star/delta connected step-down transformer. The primary of the transformer is connected to the alternator bus and their secondary supplies power to the rectifier and also feed power to the grid control circuit and other electrical equipment.

This system has a very small response time and provides excellent dynamic performance. This system reduced the operating cost by eliminating the exciter windage loss and winding maintenance.



TOPIC:

**□ HUNTING IN SYNCHRONOUS
MACHINE**

**Lecture:
15**



SYNCHRONOUS MACHINES

Hunting in Synchronous Machine

A Synchronous Machine is named Synchronous because the speed of Rotor is equal to the speed of rotating field. The speed of rotating field is determined by the supply frequency and the number of poles in the machine and known as Synchronous speed. Any deviating in the speed of rotor from synchronous speed will lead to synchronizing force which in turn will try to maintain the speed of rotor to synchronous speed.

We come across the term **HUNTING** when we study about three phase synchronous motor operations. The word hunting is used because after the sudden application of load the rotor has to search or 'hunt' for its new equilibrium position. That phenomenon is referred to as **hunting in a synchronous motor**. Now let us know what is the condition of equilibrium in synchronous motor.

The phenomenon of oscillation of the rotor about its final equilibrium position is called **Hunting**. On the sudden application of load, the rotor search for its new equilibrium position and this process is known as **Hunting**. The Hunting process occurs in a synchronous motor as well as in synchronous generators if an abrupt change in load occurs.



SYNCHRONOUS MACHINES

Hunting in Synchronous Machine

A steady state operation of synchronous motor is a condition of equilibrium in which the electromagnetic torque is equal and opposite to load torque. In steady state, rotor runs at synchronous speed thereby maintaining a constant value of torque angle (δ). If there is a sudden change in load torque, the equilibrium is disturbed and there is resulting torque which changes the speed of the motor.

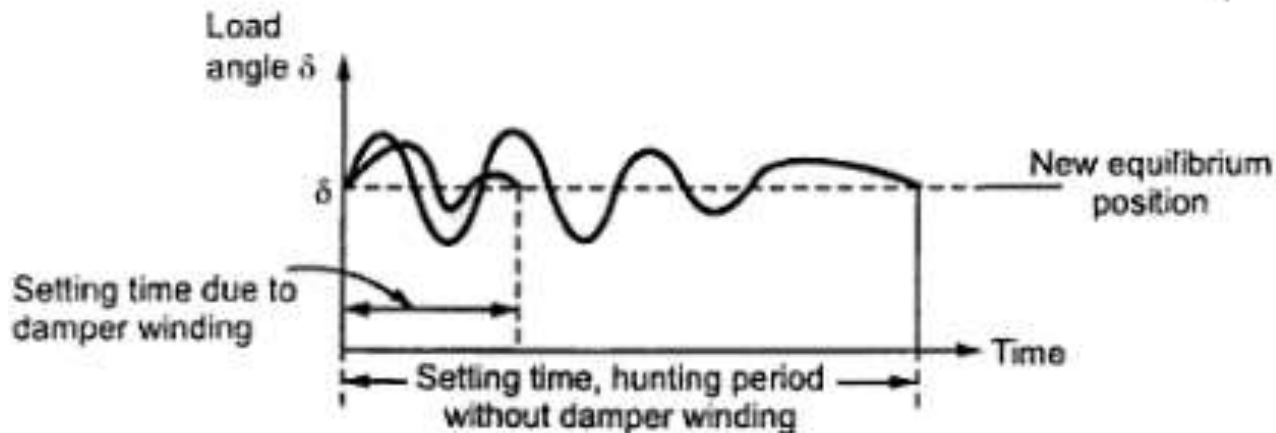

SYNCHRONOUS MACHINES

Hunting in Synchronous Machine

The steady state or stable operation of a synchronous motor is a condition of equilibrium. In it, the load torque is equal as well as opposite to the electromagnetic torque. The rotor of the motor runs at synchronous speed in the steady state condition, maintain a constant value of the torque angle δ . The equilibrium gets disturbed if a sudden change occurs in the load torque. Thus, a resulting torque takes place which changes the speed of the motor. It is given by the equation shown below.

$$T_e - T_{\text{load}} = J \frac{d\omega_M}{dt}$$

Where

J is the moment of inertia

ω_M is the angular velocity of the rotor in mechanical units.

The speed of the motor slows down temporarily, and the torque angle δ is sufficiently increased. This is done to restore the torque equilibrium and the synchronous speed when there is a sudden increase if the load torque.



SYNCHRONOUS MACHINES

Hunting in Synchronous Machine

The electromagnetic torque is given by the equation shown below.

$$T_e = \frac{3 V E_f}{\omega_s X} \sin \delta$$

If the value of δ is increased, the electromagnetic torque is also increased. As a result, the motor is accelerated. As the rotor reaches the synchronous speed, the torque angle δ is larger than the required value. Here the rotor speed continues to increase beyond the synchronous speed.

As the rotor accelerates above synchronous speed, the torque angle δ decreases. The point where the motor torque becomes equal to the load torque, the equilibrium is not restored because now the rotor speed is greater than the synchronous speed. Therefore, the rotor continues to swing backwards and as a result, the torque angle goes on decreasing.



SYNCHRONOUS MACHINES

Hunting in Synchronous Machine

When the load angle δ becomes less than the required value, the mechanical load becomes greater than the developed power. Therefore, the motor starts to slow down. The load angle starts increasing again. Thus, the rotor starts to swing or oscillates around the synchronous speed.

The motor responds to a decreasing load torque by a temporary increase in speed and a reduction of the torque angle δ . Thus, the rotor swings and rotate around the synchronous speed. Thus, this process of rotation of the rotor speed equal or around the synchronous speed is known as Hunting. Since, during the rotor oscillation, the phase of the phasor E_f changes about phasor V . Thus, hunting is known as **Phase Swinging**.



SYNCHRONOUS MACHINES

Hunting in Synchronous Machine

Causes of Hunting

The various causes of hunting are as follows:-

1. Sudden changes of load.
2. Faults were occurring in the system which the generator supplies.
3. Sudden change in the field current.
4. Cyclic variations of the load torque.

Effect of Hunting

The various effects of hunting are as follows:-

1. It can lead to loss of synchronism.
2. It can cause variations of the supply voltage producing undesirable lamp flicker.
3. The possibility of Resonance condition increases. If the frequency of the torque component becomes equal to that of the transient oscillations of the synchronous machine, resonance may take place.
4. Large mechanical stresses may develop in the rotor shaft.
5. The machine losses increases and the temperature of the machine rises.



SYNCHRONOUS MACHINES

Hunting in Synchronous Machine

Reduction of Hunting in Synchronous Motor

The following technique given below is used to reduce the phenomenon of hunting.

1. By using flywheel

The prime mover is fitted with a flywheel. It is increase the inertia and maintains the rotor speed at constant.

2. By using damper winding

Damper winding's are placed in rotor pole faces. It is made from low resistance copper bars. Which are short circuited at both end but copper rings. Damper winding cuts the stator rotating flux. hence, emf is induced in it according to the lenz's Law. This emf oppose the oscillation. So By damping winding we can damped the oscillation. The magnitude of damping torque is proportional to the slip speed.

3. Designing synchronous machine with suitable synchronizing power coefficients.



SYNCHRONOUS MACHINES

Applications of Synchronous Motors

Synchronous motors are usually used in large sizes because in small sizes they are costlier as compared with induction machines.

- The principal advantages of using synchronous machine are as follows:
- Power factor of synchronous machine can be controlled very easily by controlling the field current.
- It has very high operating efficiency and constant speed.
- For operating speed less than about 500 rpm and for high-power requirements (above 600 KW) synchronous motor is cheaper than induction motor such as rolling mills, chippers, mixers, pumps, compressors etc.
- In view of these advantages, synchronous motors are preferred for driving the loads requiring high power at low speed; e.g.; reciprocating pumps and compressor, crushers, rolling mills, pulp grinders etc.



SYNCHRONOUS MACHINES

Applications of Synchronous Motors

- Synchronous motor having no load connected to its shaft is used for power factor improvement.
- As synchronous motor is capable of operating under either leading or lagging power factor, it can be used for power factor improvement.
- A synchronous motor under no-load with leading power factor is connected in a power system where static capacitors cannot be used.



TOPIC:

- **STARTING OF A SYNCHRONOUS MOTOR**

**Lecture:
14**



SYNCHRONOUS MACHINES

Starting of a Synchronous Motor

The motor which runs at synchronous speed is known as the synchronous motor. The synchronous speed is the constant speed at which motor generates the electromotive force. The synchronous motor is used for converting the electrical energy into mechanical energy.

The stator and the rotor are the two main parts of the synchronous motor. The stator becomes stationary, and it carries the armature winding of the motor. **The armature winding is the main winding because of which the EMF induces in the motor.** The rotor carry the field windings. The main field flux induces in the rotor. The rotor is designed in two ways, i.e., the salient pole rotor and the non-salient pole rotor.

The synchronous motor uses the salient pole for designing the medium and low-speed motor. For obtaining the high-speed cylindrical rotor is used in the motor.

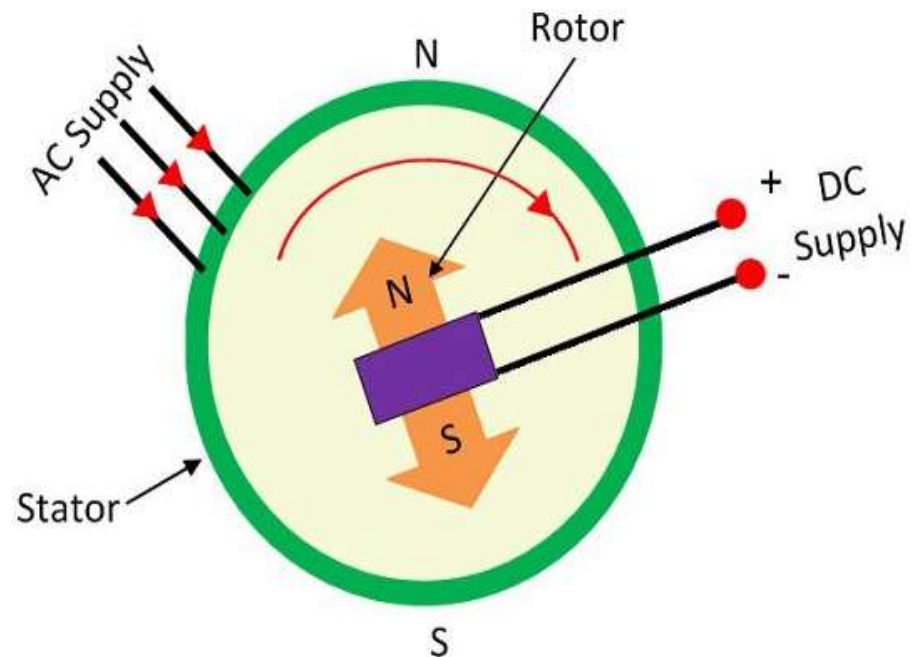

SYNCHRONOUS MACHINES

Starting of a Synchronous Motor

Main Features of Synchronous Motor

Synchronous motors are widely used in the industry for high-precision applications. This motor runs at constant speed and it does not depend on the torque acting on it. So it has a constant-speed torque characteristic. The efficiency of synchronous motor is around 90%–93%

The speed of the synchronous motor is independent of the load, i.e., the variation of the load does not affect the speed of the motor.

The synchronous motor is not self-starting. The prime mover is used for rotating the motor at their synchronous speed.

The synchronous motor operates both for leading and lagging power factor.



SYNCHRONOUS MACHINES

Starting of a Synchronous Motor

why the synchronous motor is not self-starting. So here is a general **method to start synchronous motor.**

1. Three phase winding is given a three phase ac supply. Now a rotating magnetic field is produced which is rotating at synchronous speed N_s rpm.
2. Now make the rotor to rotate in the direction of the rotating magnetic field at a speed very near to that of synchronous speed using some external equipment like a diesel engine.
3. Now switch on the dc supply given to the rotor so that rotor poles are produced. Now there are two fields one is rotating magnetic field produced by stator while the other is produced by the rotor which is physically rotated almost at the same speed as that of rotating magnetic field.
4. At a particular instant, both the fields are magnetically locked. The stator field pulls rotor field into synchronism. Now we can remove external device used to rotate rotor can be removed. But rotor will continue to rotate at the same speed as that of rotating magnetic field i.e. N_s due to **magnetic locking**.



SYNCHRONOUS MACHINES

Starting of a Synchronous Motor

A synchronous motor is a device which converts the AC into mechanical work at synchronous speed. The **starting** of the **Synchronous Motor** does not take place on its own. This means that the Synchronous Motor is **not Self Starting**. The average synchronous motor torque is zero at rest. For a net average torque, the motor must reach near synchronous speed. Some auxiliary device is, therefore, necessary to bring the synchronous motor up to near synchronous speed. The methods most commonly used to bring the motor up to synchronous speed are:

1. Starting with the help of a damper winding.
2. Starting with the help of a separate small induction motor.
3. Starting by using a dc motor coupled to the synchronous motor.
4. Starting as an induction motor and run as a synchronous motor.



SYNCHRONOUS MACHINES

Starting of a Synchronous Motor

Starting with the help of a damper winding

To enable the synchronous machine to start independently as a motor, a damper winding is used. It is an additional winding in the synchronous machine which is provided in the pole face slots in addition to the normal field winding. Bars of aluminum, copper, bronze, or similar alloys are inserted in slots of pole shoes as shown in Fig. These bars are short-circuited by end-rings on each side of the poles. Thus these short-circuited bars form a squirrel-cage winding.

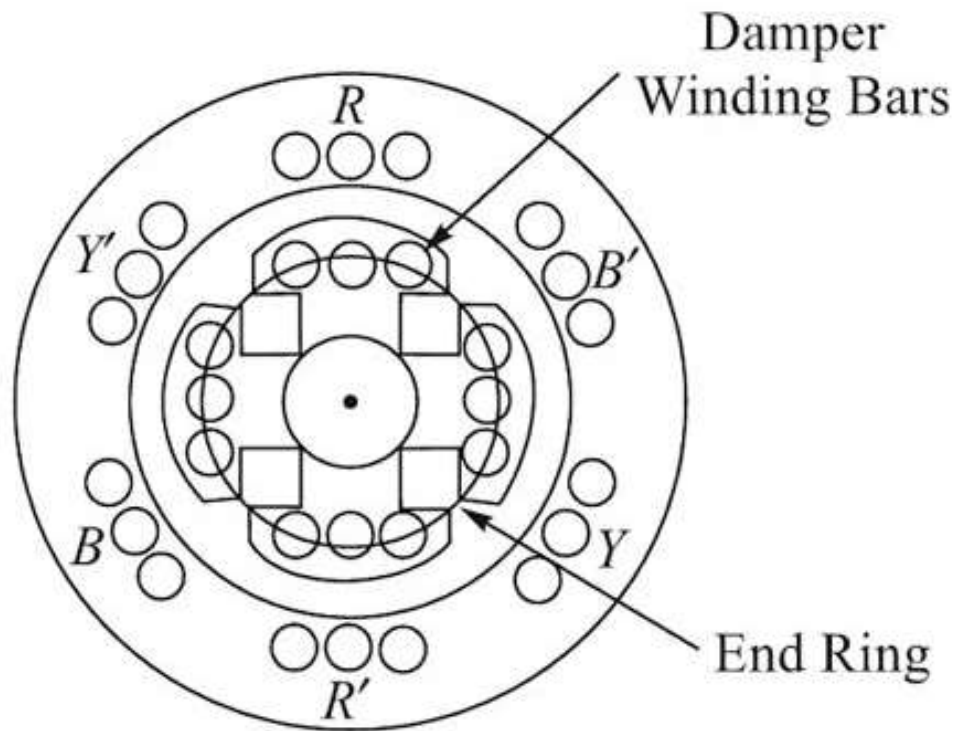

Damper winding made on pole faces of a synchronous machine



SYNCHRONOUS MACHINES

Starting of a Synchronous Motor

Starting with the help of a damper winding

When a three-phase supply is given to the stator, the synchronous motor with damper winding will start as a three-phase induction motor with the speed of rotation near to synchronous speed.

When the motor has reached near synchronous speed as an induction motor, the d.c excitation is applied to the stator winding (field winding), and by the time the exciter voltage has built up sufficiently to magnetize the rotor poles the rotor will be pulled into synchronism. Once this speed has been attained, the rotor continues to run in synchronism.

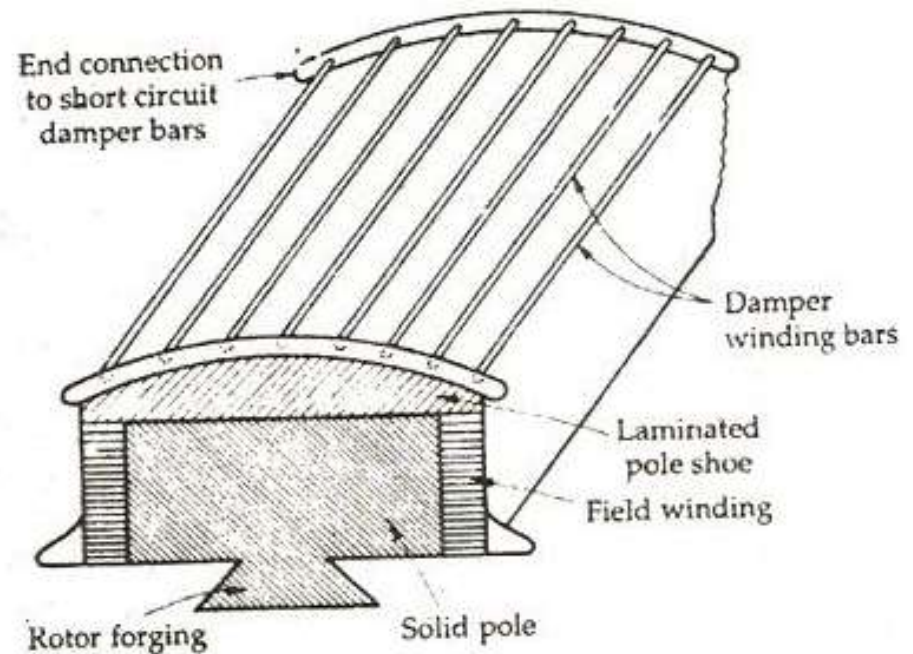

SYNCHRONOUS MACHINES

Starting of a Synchronous Motor

Starting with the help of a damper winding

When the rotor rotates at synchronous speed, the relative motion between damper winding and the rotating magnetic field is zero. Hence when the motor is running as a synchronous motor, there cannot be any induced e.m.f. in the damper winding. So damper winding is active only at the start, to run the motor as an induction motor at start.

A reduced supply voltage may be necessary, to limit the starting current drawn by the motor. In this method since starting is done as an induction motor, the starting torque developed is rather low. Hence a large capacity synchronous motor may not be able to start on full load if damper winding starting is employed. This method is only suitable when the load is small or there is no load.

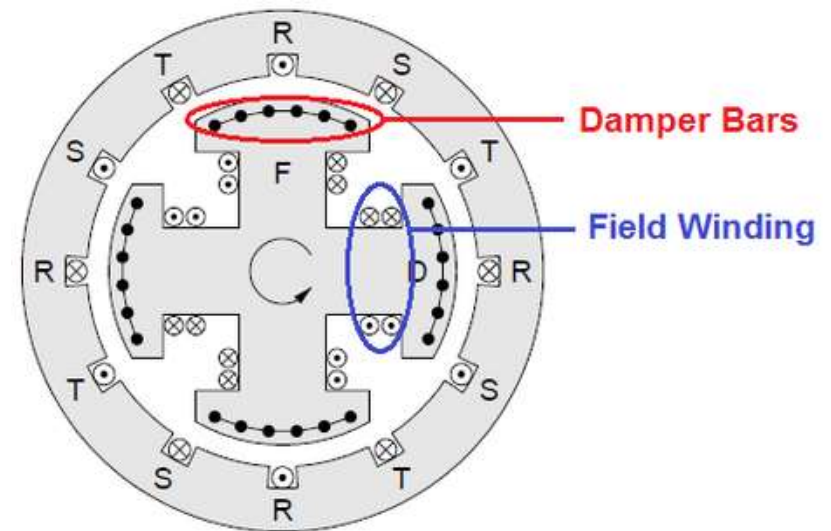

SYNCHRONOUS MACHINES

Starting of a Synchronous Motor

As a Slip Ring Induction Motor

A squirrel cage induction motor does not provide high starting torque. So to achieve this, instead of shorting the damper Winding, it is designed to form a three phase star or delta connected winding.

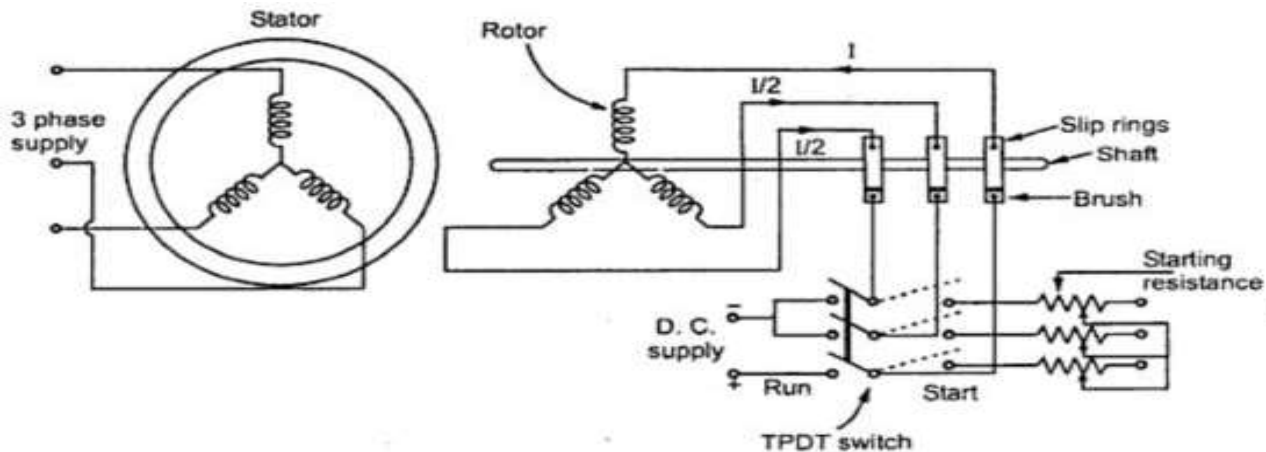

The three ends of this winding are brought out through slip rings. An external rheostat then can be introduced in series with the rotor circuit. So when the stator is excited, the motor starts as a slip ring induction motor and due to resistance added in the rotor provides high starting torque.

The resistance is then gradually cut off, as motor gathers speed. When motor attains speed near synchronous, d.c. excitation is provided to the rotor, then motor gets pulled into synchronism and starts rotating at **synchronous speed**. The **damper winding** is shorted by shorting the slip rings.

SYNCHRONOUS MACHINES

Starting of a Synchronous Motor

Using Small D.C. Machine

Many times, large synchronous motors are provided with a coupled dc machine. This machine is used as a dc motor to rotate the synchronous motor at asynchronous speed. Then the excitation to the rotor is provided. Once the motor starts running as a synchronous motor, the same dc machine acts as a dc generator called exciter. The field of the synchronous motor is then excited by this exciter itself.

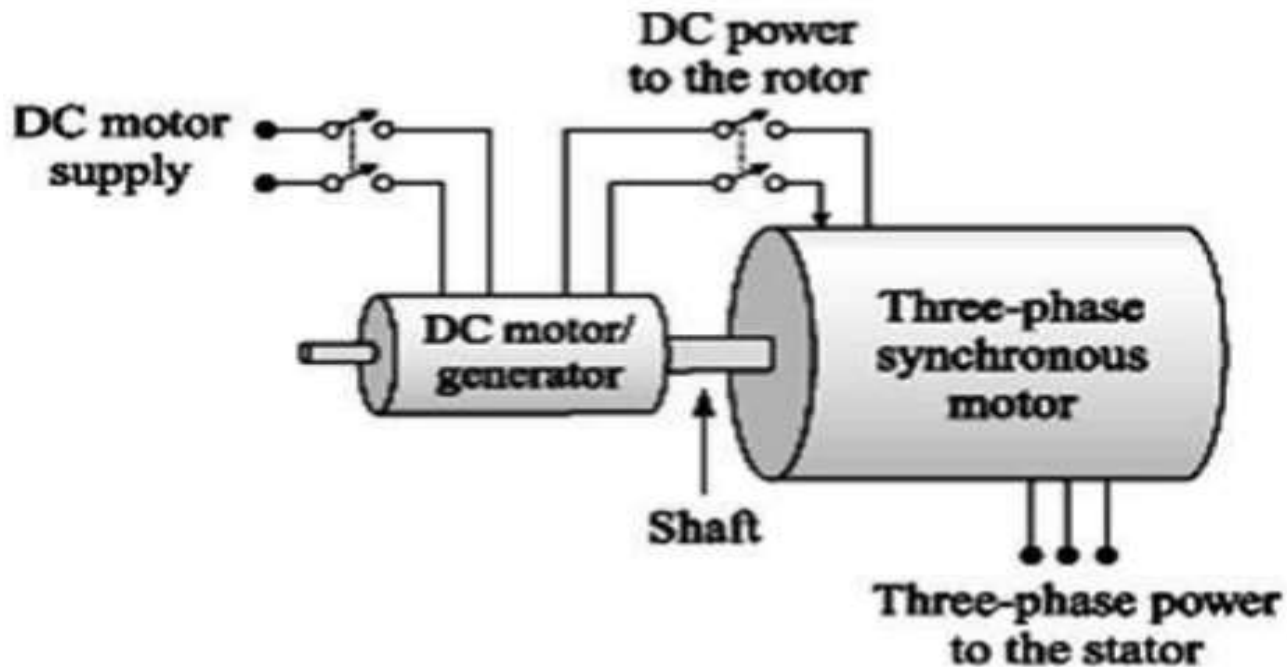

SYNCHRONOUS MACHINES

Starting of a Synchronous Motor

Using pony Motors

In this method, some external devices like small induction motor used to bring rotor near to synchronous motor. This external device is called **Pony motor**.

When the rotor attains synchronous speed, dc excitation to the rotor is switched on. After some time synchronism is developed and then pony motor is decoupled. Due to synchronism promoter continues to rotate as a synchronous motor.



TOPIC:

- **TWO REACTION THEORY –
SALIENT POLE SYNCHRONOUS
MACHINE**

**Lecture:
13**

SYNCHRONOUS MACHINES

Two Reaction Theory – Salient Pole Synchronous Machine

We knew that in non-salient pole type alternators the air gap is uniform. Due to the uniform air gap, the field flux, as well as armature flux varies sinusoidal in the air gap. In non-salient pole alternators, air gap length is constant and reactance is also constant. This two reaction theory was given by **Professor Andre Blondel** so it is named as **Blondel two reaction theory**.

The theory proposes to resolve the given armature MMFs into two mutually perpendicular components, with one located along the axis of the rotor of the salient pole. It is known as the **direct axis** or **d axis** component. The other component is located perpendicular to the axis of the rotor salient pole. It is known as the **Quadrature axis** or **q axis** component.

Due to this, the MMFs of armature and field act upon the same magnetic circuit all the time hence can be added vectorially. But in **salient pole type alternators**, the length of the air gap varies and the reluctance also varies. Hence the armature flux and field flux cannot vary sinusoidal in the air gap. The reluctances of the magnetic circuits on which MMFs act are different in the case of salient pole alternators.



SYNCHRONOUS MACHINES

Two Reaction Theory – Salient Pole Synchronous Machine

Hence the armature and field m.m.f.s are given special importance while given less importance in a non-salient pole alternator. There are some disturbing factors in **salient pole alternators**. The theory which gives the method of analysis of the disturbing effects caused by salient pole construction is called **Two Reaction Theory**.

According to this theory, the armature m.m.f. can be divided into two components as,

- 1. The component acting along the pole axis called **direct axis**.*
- 2. The component acting at right angles to the pole axis called **Quadrature axis**.*



SYNCHRONOUS MACHINES

Two Reaction Theory – Salient Pole Synchronous Machine

The component which is acting along the direct axis can be magnetizing or demagnetizing. The component which is acting along Quadrature axis is crossly magnetizing. These components produce the effects of different kinds. The below figure shows the stator MMF wave and the flux distribution in the air gap along **the direct axis** and Quadrature axis of the pole.

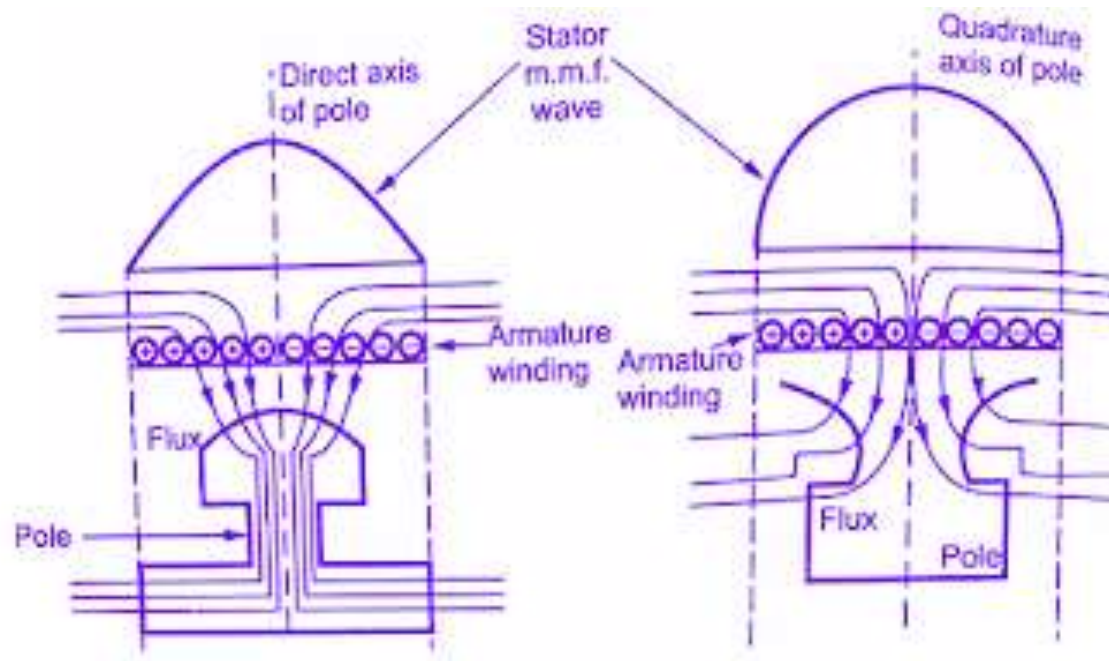

SYNCHRONOUS MACHINES

Two Reaction Theory – Salient Pole Synchronous Machine

The reluctance offered to the MMF wave is lowest when it is aligned with the field pole axis. This axis is called the direct axis of pole i.e. d-axis. The reluctance offered is highest when the MMF wave is oriented at 90° to the field pole axis which is called Quadrature axis i.e. q-axis.

The air gap is least in the center of the poles and progressively increase, on moving away from the center. Due to such shape of the pole-shoes, the field winding wound on salient poles produces the MMF wave which is nearly sinusoidal and it always acts along the pole axis which is the direct axis.

Let F_f be the MMF wave produced by field winding, then it always acts along the direct axis. This MMF is responsible for producing an excitation EMF E_f which lags F_f by all angle 90° .

When armature carries current, it produces its own MMF wave F_A . This can be resolved into two components, one acting along d-axis (magnetizing or demagnetizing) and one acting along q-axis (cross-magnetizing). Similarly, armature current I_a also can be divided into two components, one along the direct axis and one along Quadrature axis. These components are denoted as,

F_A :

F_d = component along the direct axis

F_q = component along Quadrature axis

I_a :

I_d = component along direct axis

I_q = component along Quadrature axis



SYNCHRONOUS MACHINES

Two Reaction Theory – Salient Pole Synchronous Machine

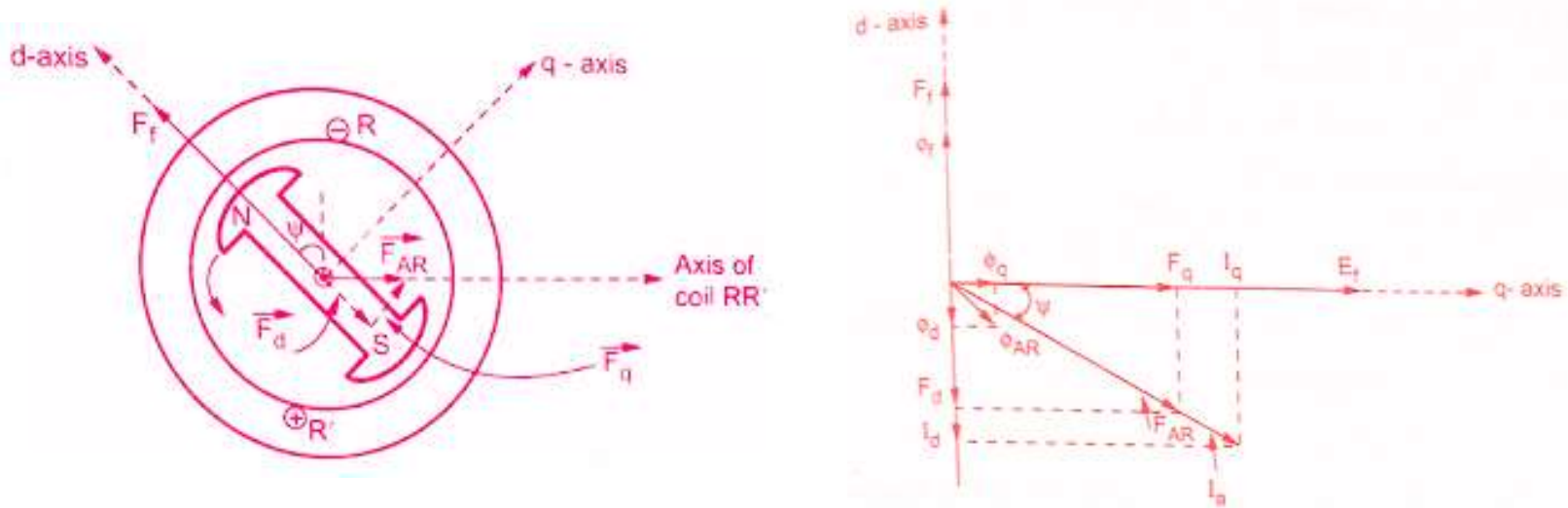

It can be observed from the figure that F_d is produced by I_d which is at 90° to E_f while F_q is produced by I_q which is in phase with E_f . The flux components of Φ_{AR} which are Φ_d and Φ_q respectively are also shown in the figure.

It can be noted that the reactance offered to flux along the direct axis is less than the reactance offered to flux along Quadrature axis. Due to this, the flux Φ_{AR} is no longer along F_{AR} or I_a . Depending upon the reluctances offered along the direct and Quadrature axis, the flux Φ_{AR} lags behind armature current I_a .



SYNCHRONOUS MACHINES

Two Reaction Theory – Salient Pole Synchronous Machine

Direct and Quadrature Axis Synchronous Reactance's

We already know that the armature reaction flux Φ_{AR} has two components, one is Φ_d along the **direct axis** and Φ_q along **Quadrature axis**. These fluxes are proportional to the respective MMF magnitudes and the permeance of the flux path oriented along the respective axes. Here below we are going to derive the terminal voltage in **Blondel two reaction theory**.

$$\Phi_d = P_d F_d$$

where P_d = Permeance along the direct axis

Permeance is the reciprocal of reluctance and indicates ease with which flux can travel along the path.

But $F_d = \text{M.M.F.} = K_{ar} I_d$ in phase with I_d

The MMF is always proportional to current. While K_{ar} is the armature reaction coefficient.

$$\therefore \Phi_d = P_d K_{ar} I_d$$

Similarly $\Phi_q = P_q K_{ar} I_q$

As the reluctance along the **direct axis** is less than that along **Quadrature axis**, permeance P_d along the direct axis is more than that along **Quadrature axis**, ($P_d > P_q$).



TOPIC:

□ SHORT CIRCUIT RATIO OF A SYNCHRONOUS MACHINE

**Lecture:
12**



SYNCHRONOUS MACHINES

Short Circuit Ratio of a Synchronous Machine

The **Short Circuit Ratio (SCR)** of a synchronous machine is defined as the ratio of the field current required to generate rated voltage on an open circuit to the field current required to circulate rated armature current on short circuit. The short circuit ratio can be calculated from the **open circuit characteristic (O.C.C)** at rated speed and the **short circuit characteristic (S.C.C)** of a three-phase synchronous machine

Short Circuit Ratio, or SCR, is the ratio of field current required to generate rated voltage under open circuit condition, to the field current required to circulate the rated armature current under three phase short circuit condition. It is an important quantity of synchronous machine which helps in estimation of operating characteristics. It is also useful for obtaining the size of machine for a given rating and type.

The value of Short Circuit Ratio varies from 0.5 to 0.8 for Turbo Generator, 1 to 1.4 for Hydro generator and 0.4 to 0.5 for synchronous condenser.



SYNCHRONOUS MACHINES

Short Circuit Ratio of a Synchronous Machine

Calculation

Short Circuit Ratio can easily be obtained from the Open Circuit (OCC) and Short Circuit Characteristics (SCC) of Synchronous machine. Figure below shows the OCC and SCC.

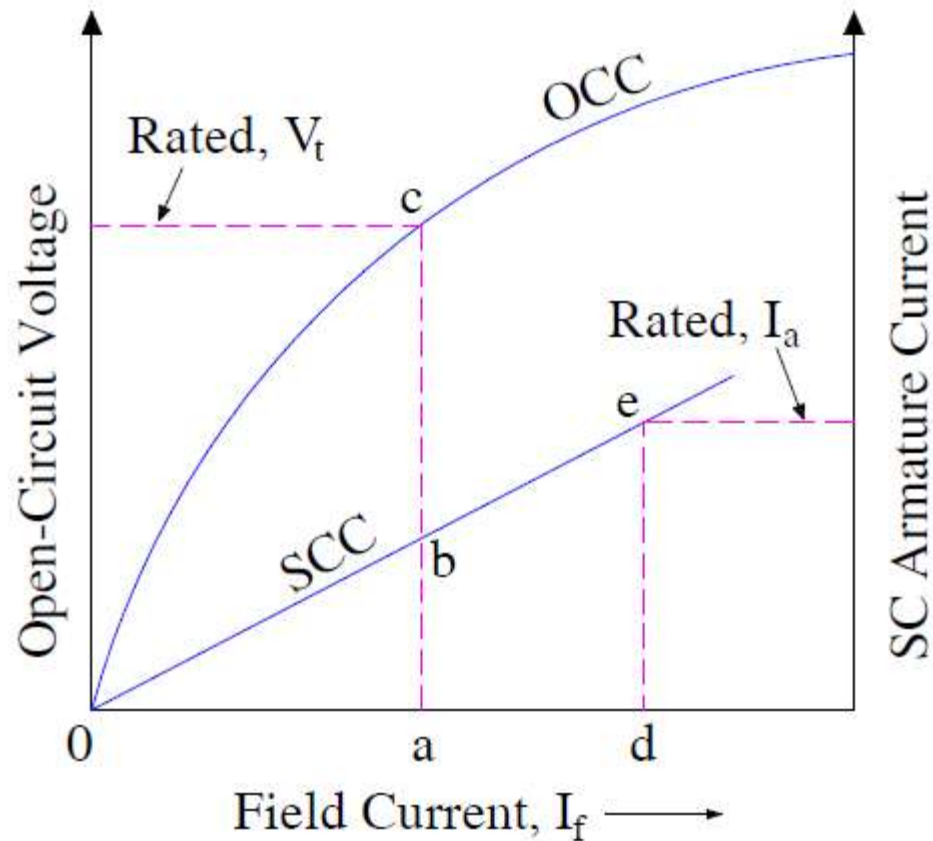

SYNCHRONOUS MACHINES

Short Circuit Ratio of a Synchronous Machine

Calculation

From the figure, the short circuit ratio is given by the equation shown below.

$$\text{SCR} = \frac{I_f \text{ for rated O.C voltage}}{I_f \text{ for rated S.C current}} = \frac{Oa}{Od}$$

Since the triangles Oab and Ode are similar. Therefore,

$$\text{SCR} = \frac{Oa}{Od} = \frac{ab}{de}$$

The direct axis synchronous reactance X_d is defined as the ratio of open circuit voltage for a given field current to the armature short circuit current for the same field current.

For the field current equal to Oa, the direct axis synchronous reactance in ohms is given by the equation shown below.

$$X_{d \Omega} = \frac{ac}{ab}$$

The per unit value of X_d is given as

$$X_{d \text{ pu}} = \frac{X_{d \Omega}}{\text{Base impedance}}$$

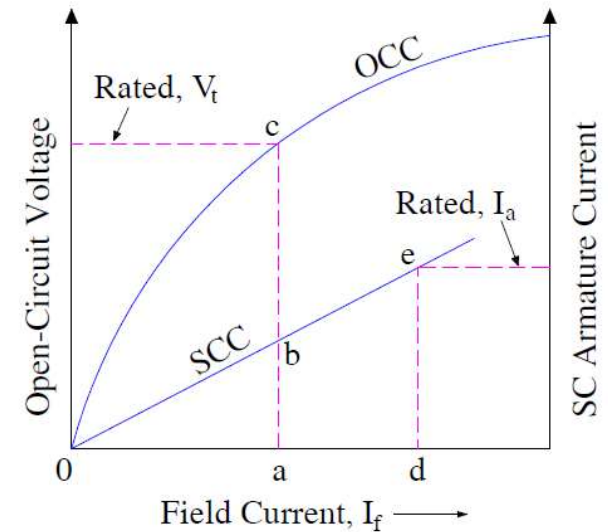

SYNCHRONOUS MACHINES

Short Circuit Ratio of a Synchronous Machine

Calculation

But, the base impedance is

$$\text{Base Impedance} = \frac{\text{per phase rated voltage}}{\text{per phase rated armature current}}$$

$$\text{Base Impedance} = \frac{V_{\text{rated}}}{I_{\text{a rated}}} = \frac{\text{ac}}{\text{de}} \Omega$$

Therefore,

$$X_{\text{d pu}} = \frac{\text{ac}}{\text{ab}} \times \frac{\text{de}}{\text{ac}} = \frac{\text{de}}{\text{ab}}$$

$$\text{SCR} = \frac{\text{ab}}{\text{de}} = \frac{1}{(\text{de}/\text{ab})} = \frac{1}{X_{\text{d pu}}}$$

It is clear that the short circuit ratio is equal to the reciprocal of the per unit value of the direct axis synchronous reactance.

In a saturated magnetic circuit, the value of X_{d} depends upon the degree of saturation.



SYNCHRONOUS MACHINES

Short Circuit Ratio of a Synchronous Machine

Significance of Short Circuit Ratio (SCR)

Short Circuit Ratio is an important factor of the synchronous machine. It affects the operating characteristics, physical size and cost of the machine. The Large variation in the terminal voltage with a change in load takes place for the lower value of the short circuit ratio of a synchronous generator. To keep the terminal voltage constant, the field current (I_f) has to be varied over a wide range.

The synchronous inductance is given as

$$L_s \propto \frac{1}{\text{reluctance of air gap}}$$

Therefore,

$$\text{SCR} \propto \frac{1}{L_s}$$

Hence, the short circuit ratio is directly proportional to the air gap reluctance or air gap length.



SYNCHRONOUS MACHINES

Short Circuit Ratio of a Synchronous Machine

Significance of Short Circuit Ratio (SCR)

Low SCR:

Low value of SCR simply means greater value of X_d . The voltage regulation is greatly affected by direct axis reactance. More the value of X_d , the poor will be the voltage regulation. This means that, the terminal voltage will widely vary with variation in load. In order to main constant terminal voltage, the field current needs to be varied widely and therefore the load on the excitation system will increase.

Greater value of direct axis reactance X_d also affects the stability of synchronous machine. The synchronizing power of synchronous machine is defined as the degree by which the machine has a tendency to get synchronized with the infinite Grid just after experiencing disturbance. Low value of synchronizing power means, the machine will have fewer tendencies to get synchronized again after recovering from disturbance

Synchronizing Power is inversely proportional to reactance X_d , lower value of short circuit ratio results in lower stability limit.

The only advantage of lower SCR is the lower value of armature current during three phase short circuit.



SYNCHRONOUS MACHINES

Short Circuit Ratio of a Synchronous Machine

High SCR:

High value of short circuit ratio gives improved voltage regulation. Thus the terminal voltage is practically constant during the load variation. It also results in better stability limit due to increased value of synchronizing power.

But the disadvantage of high value of SCR is increased armature current during three phase short circuit and increased machine size.



SYNCHRONOUS MACHINES

Short Circuit Ratio of a Synchronous Machine

Size and Cost of Machine

SCR greatly affects the size and hence the cost of machine. To better understand the effect of Short Circuit Ratio on the size of machine, let us assume that the air gap length is doubled. The mutual inductance M_d , in terms of direct axis (d-axis) synchronous reactance X_d can be written as,

$$M_d \propto 1/\text{d-axis reactance}$$

Doubling the air gap length doubles the reluctance. Therefore, the magnetic flux linkage becomes half. Thus the mutual inductance reduces to half of its original value. To main same open circuit terminal voltage, filed current must be doubled.

The short circuit current I_{sc} is given as

$$\begin{aligned} I_{sc} &= E_f / X_d \\ &= M_d \omega I_f / \sqrt{3} \omega L_d \\ &= M_d I_f / \sqrt{3} L_d \end{aligned}$$

where L_d is direct axis inductance.



SYNCHRONOUS MACHINES

Short Circuit Ratio of a Synchronous Machine

Size and Cost of Machine

When air gap length is doubled, mutual inductance M_d and self inductance L_d are equally affected. Therefore, the field current required to circulate the rated armature current remains same. It is thus observed that when air gap length is doubled,

Field current is doubled for maintain same open circuit voltage

Field current remains same for circulating rated armature current

As per the definition of SCR, doubling the air gap length doubles the short circuit ratio. With double the air gap, the field current required to generate the same open circuit terminal voltage is doubled. This requires greater cross-section of field winding and hence greater field copper. This increased amount of copper field winding can only be wound if the field pole size is increased. Subsequently, the machine diameter increases and hence overall size, weight and cost of machine increases.



TOPIC:

**□ POWER ANGLE CURVE OF
SYNCHRONOUS MACHINE**

**Lecture:
11**



SYNCHRONOUS MACHINES

Power Angle Curve of Synchronous Machine

Power Angle Curve of Synchronous Machine is the graphical representation of electrical output with respect to the power angle. As we know, power angle is also known as load angle, therefore it can be said that this curve is graphical representation of electrical output of generator with respect to load angle.

First of all, we should know the mathematical relation between the electrical output of synchronous machine in terms of load angle to get the graph of power versus load angle. The electrical output of synchronous generator is given as below.

$$P_e = (E_f V_t / X_s) \sin \delta$$

Where E_f , V_t , X_s and δ are no load excitation voltage, generator terminal voltage, generator synchronous reactance and load angle respectively. You are requested to read “Power Flow Equation through an Inductive Load” for getting the detail of derivation part of the above expression of electrical output.

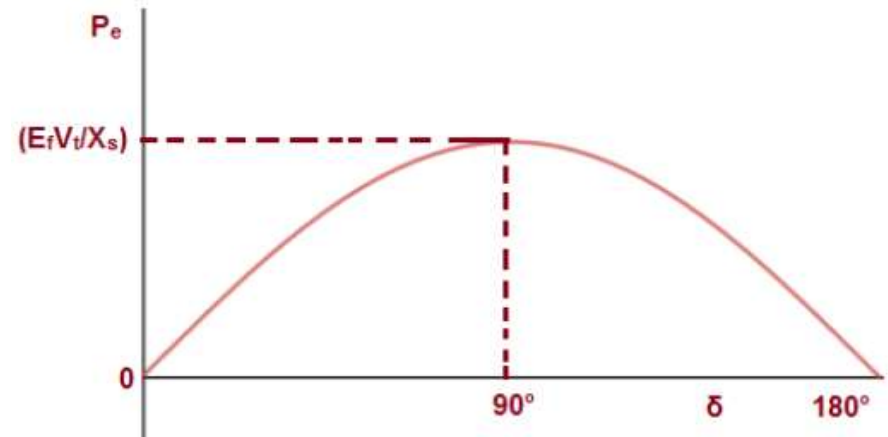

SYNCHRONOUS MACHINES

Power Angle Curve of Synchronous Machine

Importance of Power Angle Curve

Power Angle Curve tells us about the electrical power output of synchronous machine when power angle δ is varied. It can be seen from this curve that as we increase δ from 0 to 90°, the output increases sinusoidal. But a further increase in power angle δ beyond 90°, the generator electrical output decreases.

This simply means that, the generator electrical output is less than the mechanical input. Therefore, the poles of the machine will start to slip and eventually it will lose synchronism. Thus the machine i.e. generator becomes unstable. Steady state stability limit is the maximum power flows possible through a specific point without lose of synchronism, when the power is increased gradually. Therefore, steady state stability limit of synchronous machine corresponds to power for load angle $\delta = 90^\circ$. To be accurate, it will be $(E_f V_t / X_s)$.

Not only steady state stability limit rather transient stability limit is also affected by the load angle at which machine is operating. Transient state stability limit is basically the maximum amount of power flow possible without loss of synchronism when a sudden disturbance occurs. The transient stability limit is determined by Equal Area Criteria which uses power angle curve. Thus power angle curve is very important for study of stability limit of synchronous machine.

SYNCHRONOUS MACHINES

Power Angle Curve of Synchronous Machine

These three terms Torque angle, Power angle and Load angle are associated with Synchronous machines that are synchronous generator and synchronous motor. They named as Synchronous machines as they revolve at synchronous speed.

Synchronous Speed:

For a given number of poles and frequency of a system the Synchronous speed is constant and is given by

$$N_s = 120 f/p$$

Where

N_s = Synchronous speed in RPM

f = frequency

p = No. of Poles of Alternator



SYNCHRONOUS MACHINES

Power Angle Curve of Synchronous Machine

Power or Load angle for Generator

The power angle is defined as the angle between Induced EMF and Terminal voltages. For Generator action E leads V.

$$P = + \frac{|E| \cdot |V|}{X} \sin \delta$$

Where

P = power generated per phase, watts.

|E| = Induced EMF per phase, volts.

|V| = Terminal voltage per phase, volts

δ = Power angle, Angle between E and V vectors (Considered Positive for Generator)

X = Synchronous reactance of Generator, Ohms

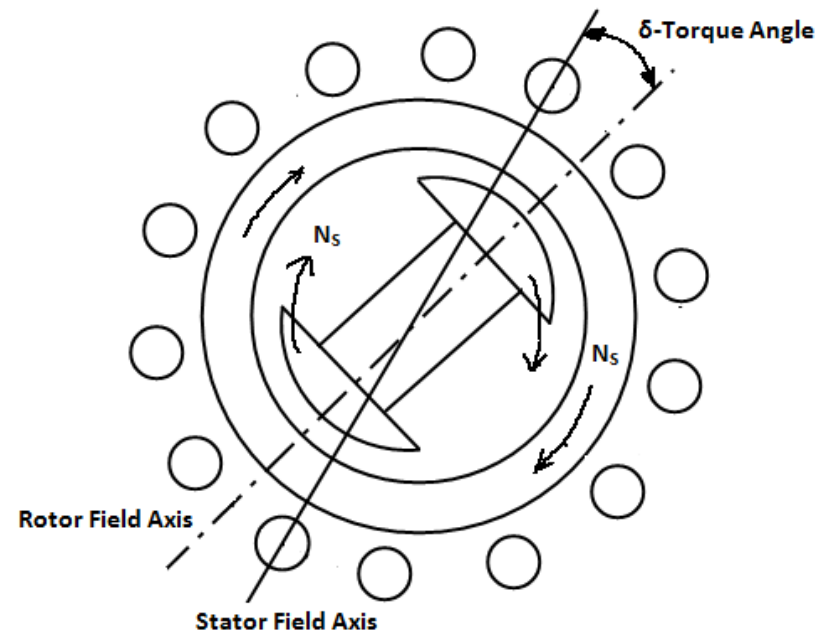

SYNCHRONOUS MACHINES

Power Angle Curve of Synchronous Machine

Power or Load angle for Generator

The typical Load angle is around 30° Electrical. With increased MW load the load angle also increases and the generator delivers more power.

The only way to vary load angle is by varying the input to the Turbine. The power output of a synchronous Generator can be changed by changing its mechanical power input. In case of alternators to deliver desired output for variable loads, Governor is used. Speed control governor maintain the turbine speed constant by varying the input (Steam or Gas or Water depends on type of Prime mover or Turbine) to the Prime mover. Governors take feedback of load on the generator and according to feed input to the turbine.

Change in excitation using **Static Excitation** or **Brushless Excitation** System gives only the change in EMF and Reactive power supplied by the machine.

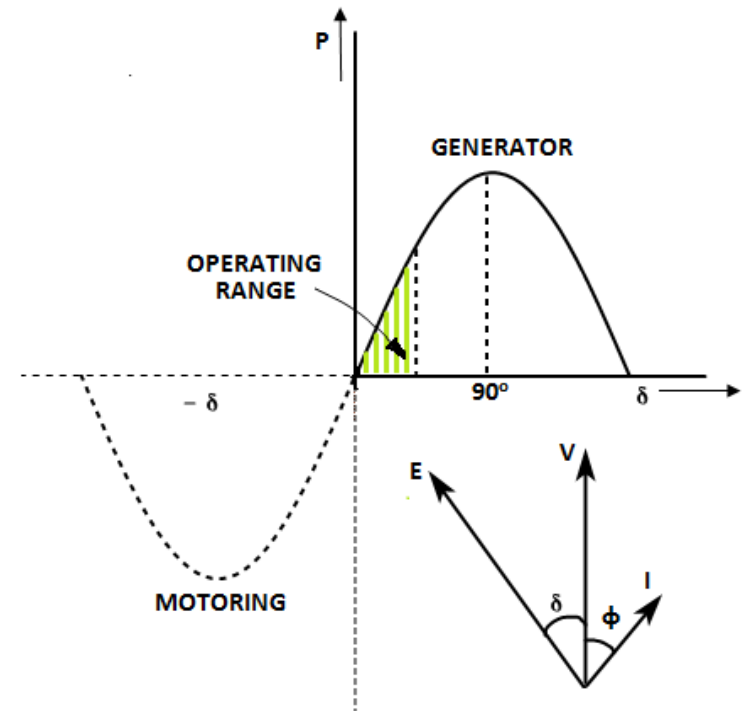

Power-Angle Curve of Synchronous Machine



SYNCHRONOUS MACHINES

Power Angle Curve of Synchronous Machine

Load angle or Power angle for Motoring Action

The power angle is defined as the angle between Induced Back EMF and applied stator voltages.

For motor action E lags V.

$$P = - \frac{|E| \cdot |V|}{X} \sin \delta$$

Where

P = Mechanical equivalent power produced per phase, watts.

|E| = Induced Back EMF per phase, volts.

|V| = Supply voltage per phase, volts

δ = Power angle, Angle between E and V vectors (Considered Negative for Motor)

X = Synchronous reactance of Motor, Ohms



SYNCHRONOUS MACHINES

Power Angle Curve of Synchronous Machine

What are the limits of Power angle

The system is stable only if the power angle δ is between -90° and $+90^\circ$ where the slope $dP/d\delta$ is positive, that is the range in which an increase in power angle results in an increase in transmitted power.

Beyond this range generator or motor comes out of synchronism and results loss of stability. Loss of stability leads to stalling of synchronous motor when that motor is supplied with synchronous generator. High fluctuation of current and voltage within the transmission network when two synchronous generators are connected. The power transfer between the sources is alternatively positive and negative with an average of zero.

Loss of synchronism is called loss of stability. If a synchronous machine losses synchronism, it is tripped automatically by the loss of synchronism protection and is not allowed to rotate asynchronously.



SYNCHRONOUS MACHINES

Power Angle Curve of Synchronous Machine

Power or Load angle for Transmission Line

The load angle is defined as the angle between sending V_s and receiving V_r end voltages.

The power transfer of AC transmission lines is related with the rated voltage as follows.

$$P = \frac{|V_S| \cdot |V_R|}{X} \sin \delta$$

Where

P = Power transfer per phase, watts

$|V_S|$ = Sending end voltage, Volts per phase.

$|V_R|$ = Receiving end voltage, Volts per phase.

δ = Power angle, Angle between V_S and V_R vectors.

X = Reactance of transmission Line, Ohms



TOPIC:

**□ ARMATURE REACTION IN
ALTERNATOR**

**Lecture:
10**



SYNCHRONOUS MACHINES

Armature Reaction in Alternator

Armature winding in an electrical machine is the winding which carries the load current. Under no-load condition, the armature current is zero. But as the machine is loaded, load current flows through the armature winding and creates magnetic flux. The effect of armature winding mmf or flux on the main working flux created by field poles is called the armature reaction. This article outlines the armature reaction in synchronous machine or alternator.

To better understand the armature reaction in synchronous machine, it is essential to first understand the internal happening. For this purpose the alternator operation is considered under different operating power factor and loads as follows:

1. No-load Operation
2. Unity power factor (pf) load
3. Zero power factor lagging load
4. Zero power factor leading load
5. Lagging power factor load



SYNCHRONOUS MACHINES

Armature Reaction in Alternator

No-load Operation

As mentioned earlier, the current through the armature winding of alternator is zero for no-load operation; therefore there will not be any armature reaction. When the field winding is excited by a DC source and the alternator / generator is brought up to synchronous speed by adjusting the speed of prime-mover, no load voltage or excitation voltage is generated across the alternator armature terminals. The value of no-load or excitation armature terminal voltage is given as

$$E_f = \sqrt{2} \pi f N_{ph} K_w \phi_f$$

Where E_f , N_{ph} , K_w and ϕ_f are excitation voltage, number of series turns per phase, winding factor and field flux respectively.

This generated excitation voltage across the armature terminal lags behind the field flux ϕ_f by 90 degree. In general, the emf generated by the field flux always lags behind the field flux by 90 degree in any machine.



SYNCHRONOUS MACHINES

Armature Reaction in Alternator

Unity Power Factor Load

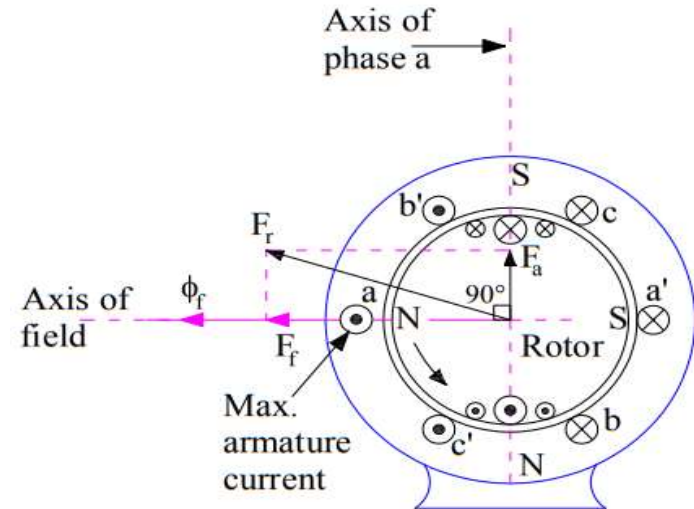
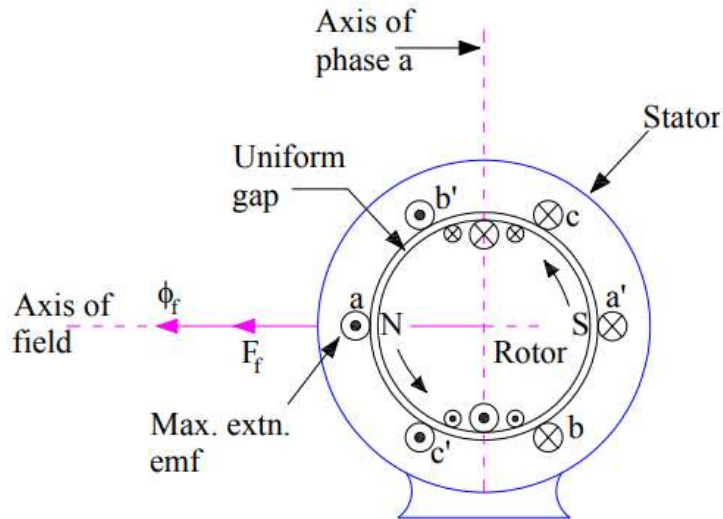

Now, when this alternator is connected to a balanced 3 phase load, a balanced three phase current starts flowing in the three phases of alternator. As the load is of unity power factor, this means that excitation voltage E_f and armature current I_a will be in phase. This can also be interpreted in another way like excitation voltage and armature current attain their peak simultaneously. Since excitation voltage is maximum in phase "a", this means armature current phase a will also be maximum. Though load current also flows in remaining two phases "b" and "c" but their magnitude is less than the maximum for this instant of time. ***The mmf set up by the armature current is called the armature reaction mmf.***

The field winding on rotor is fed by DC source for setting up working or main field mmf. Field current indicated by cross and dot in the field winding on rotor, creates field mmf F_f and field flux ϕ_f which are sinusoidal distributed along the air-gap periphery. This field flux creates North (N) and South (S) pole on the rotor.

SYNCHRONOUS MACHINES

Armature Reaction in Alternator

Unity Power Factor Load

Now, if we combine the space phasor of field mmf and armature mmf wave, then it can easily be seen that the armature reaction mmf lags behind the field mmf by 90 degree. This is shown in figure below.

The resultant air gap mmf will be the resultant of field mmf and armature reaction mmf. This means,

$$F_r = F_f + F_a$$

If we neglect the saturation, then the field flux ϕ_f and armature flux ϕ_a will be along their respective mmf wave. This is shown in the figure. Thus we can say that, armature reaction flux lags behind the field flux by 90 degree. Therefore, ***armature reaction mmf at unity power factor is entirely cross-magnetizing in nature.***

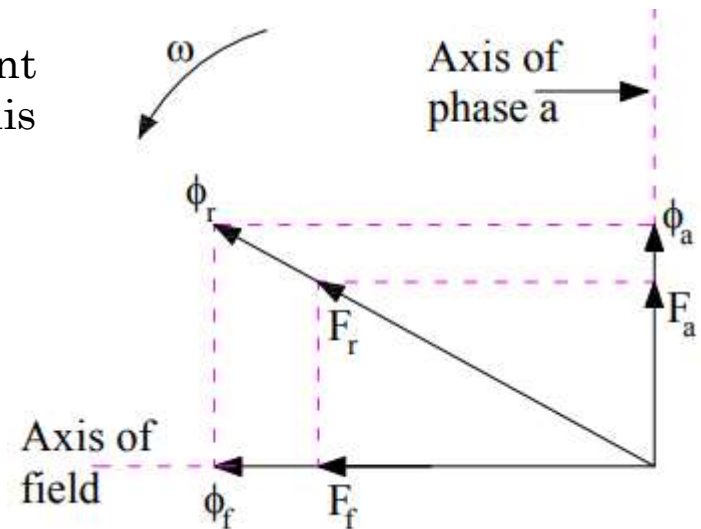

SYNCHRONOUS MACHINES

Armature Reaction in Alternator

Zero Power Factor Lagging Load

Zero power factor lagging load means that the load current is lagging behind the excitation voltage by 90 degree. This is shown in figure below.

The above phasor diagram has been drawn using the following facts:

The excitation emf lags the field mmf by 90 degree.

As saturation is neglected, the field flux will be along the field mmf.

Armature reaction mmf is along the armature current.

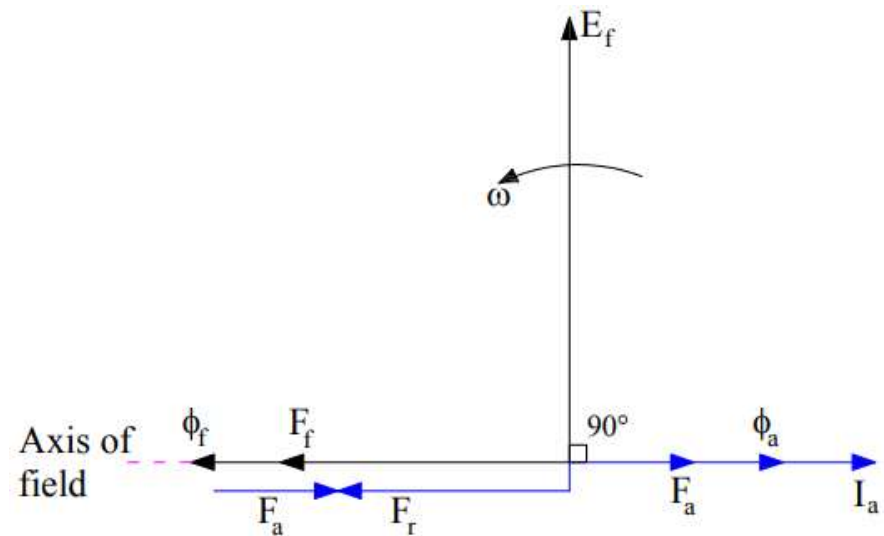

From the above phasor diagram, it is clear that armature reaction mmf F_a is in opposition of field mmf ϕ_f . This means that the resultant air-gap mmf will be equal to $(F_f - F_a)$. **Thus under zero power factor lagging loading condition of alternator, the effect of armature reaction mmf is purely demagnetizing.**



SYNCHRONOUS MACHINES

Armature Reaction in Alternator

Zero Power Factor Lagging Load

Due to zero power factor lagging load, the current in phase “a” of armature winding will become maximum when the field poles have advanced by 90 degree in assumed counter-clockwise direction. This is shown in figure below

Carefully observe the above figure. It can be seen that, in this case the direction of armature reaction mmf F_a will be along the phase “a” axis and that of field mmf F_f will be vertically downward. This direction can be found by using right hand screw rule. Thus we see that, both the armature reaction and field mmf are opposing each other. Hence, the effect of armature reaction mmf is purely demagnetizing in zero pf lagging load condition.

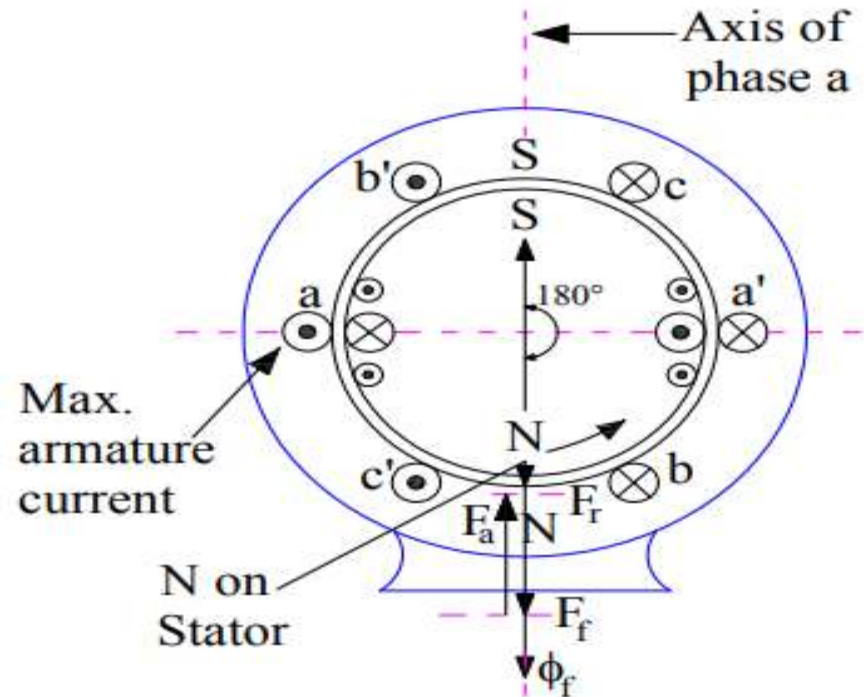

SYNCHRONOUS MACHINES

Armature Reaction in Alternator

Lagging Power Factor Load

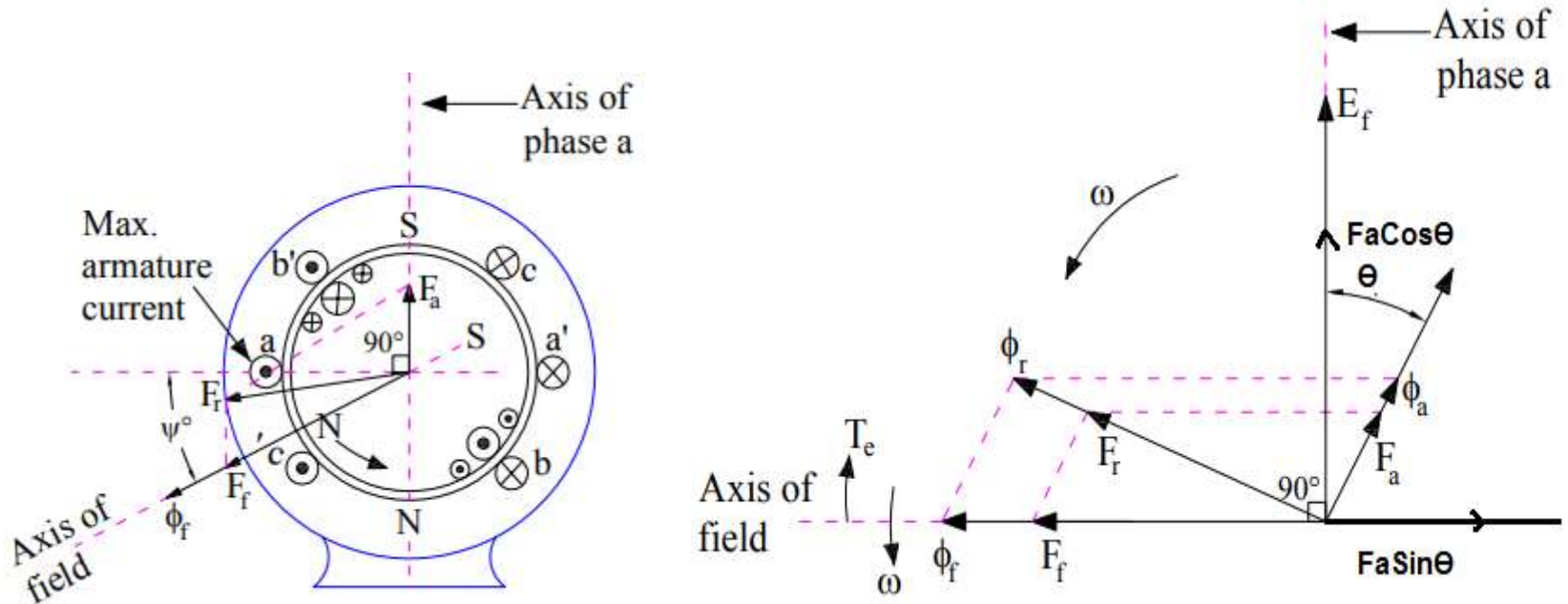

The armature reaction mmf can be resolved into two components: One along the excitation voltage E_f ($F_a \cos \theta$) and another opposite to the field mmf F_f ($F_a \sin \theta$). Thus we can say that, the effect of armature reaction in lagging pf load is cross-magnetizing as well as demagnetizing in nature.



SYNCHRONOUS MACHINES

Armature Reaction in Alternator

Zero Power Factor Leading Load

The condition of zero pf leading load may be depicted by phasor diagram in the same way that for zero pf lagging load. This is shown below.

From the above phasor, it is clear that armature reaction mmf is in the direction of field mmf. Thus the effect of armature reaction mmf under zero power factor leading loads is purely magnetizing.

The above conclusion can also be drawn by analyzing the space phasor of the alternator. Zero pf leading means that the current in phase "a" of armature winding will be zero when the field poles are behind the axis of phase "a" winding by 90 degree as shown in figure below

Therefore, the direction of field mmf and armature mmf will be same. Hence armature reaction mmf is magnetizing in nature.

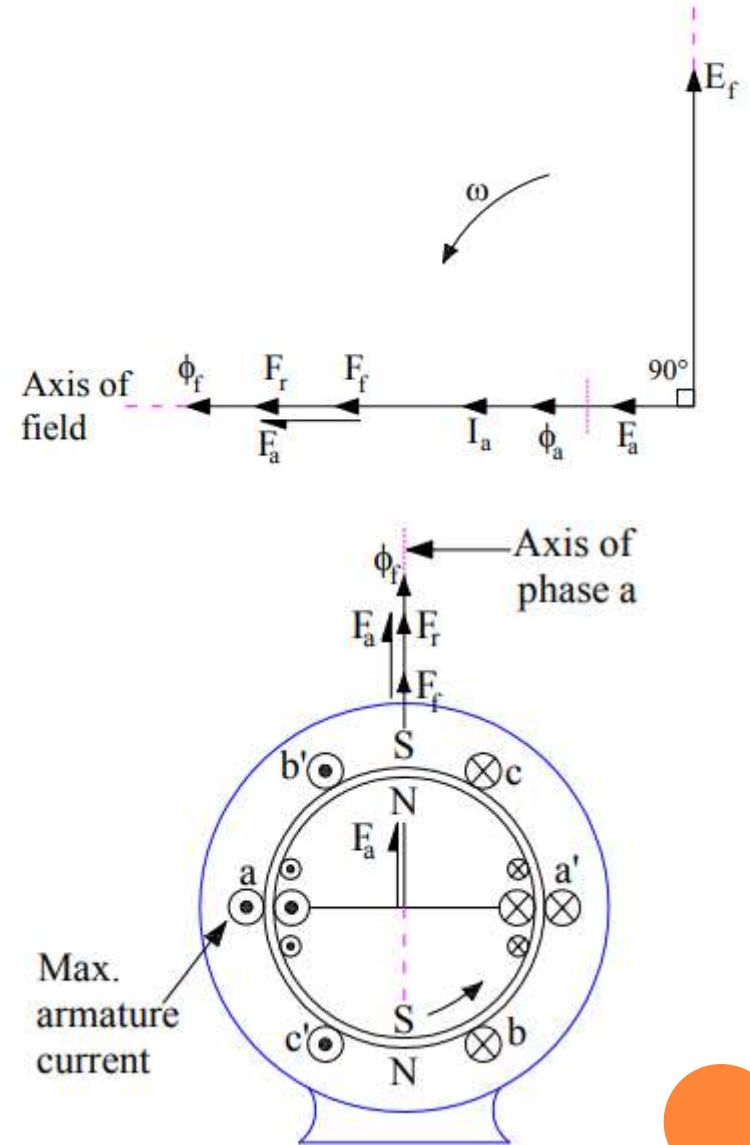

SYNCHRONOUS MACHINES

Armature Reaction in Alternator

Thus to summarize, the effect of armature reaction mmf on main field mmf of alternator is tabulated below.

Sr. No.	Loading Condition	Effect of Armature Reaction
1)	No Load	No effect
2)	Unity Power Factor	Cross-magnetizing
3)	Zero Power Factor Lagging	Purely demagnetizing
4)	Zero Power Factor Leading	Purely magnetizing
5)	Lagging Load	Cross-magnetizing and demagnetizing



TOPIC:

- **INDIRECT METHODS OF VOLTAGE REGULATION**

**Lecture:
09**



SYNCHRONOUS MACHINES

Indirect Methods of Voltage Regulation

Voltage regulation of Alternator by EMF method

The voltage regulation of alternator by EMF method involves the EMF quantities of all the armature parameters (armature resistance, Armature leakage reactance, armature reaction). The drop due to armature reaction is not considered, because it does not occur due to any of the physical element but due to interaction of armature flux with main flux.

Hence, in order to quantify the voltage drop due to armature reaction, armature winding is assumed to have a fictitious reactance called armature reaction reactance X_{ar} Ω /phase.

Now, the Sum of armature leakage reactance and armature reaction reactance is called *synchronous reactance* of an alternator X_S .

Since the drop due to the synchronous impedance is considered, this method is called *synchronous impedance method*

This method is also called *pessimistic method*, because the voltage regulation obtained by this method is more than the actual value.

$$V = E_a - Z_s I_a \quad Z_s = R_a + jX_s$$
$$X_s = X_L + X_{ar}$$

The EMF method requires the following data's to determine the voltage regulation of alternator.

- Armature resistance/phase
- Open circuit characteristics (OCC)
- Short circuit characteristics (SCC)



SYNCHRONOUS MACHINES

Indirect Methods of Voltage Regulation

Armature Resistance per phase

Armature Resistance per phase can be obtained by conducting stator resistance test on the alternator. It is done by connecting the dc voltage supply to the stator armature winding and the corresponding current is measured.

By doing so, the dc stator resistance is calculated and then by using the formula $R_{ac} = 1.3 R_{dc}$ the ac stator resistance is determined.

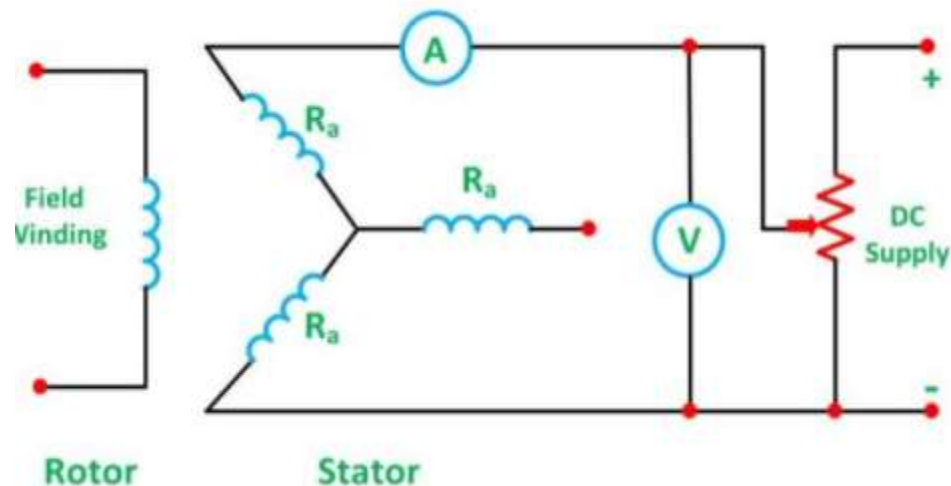

SYNCHRONOUS MACHINES

Indirect Methods of Voltage Regulation

Open circuit characteristics (OCC)

&

Short circuit characteristics (SCC)

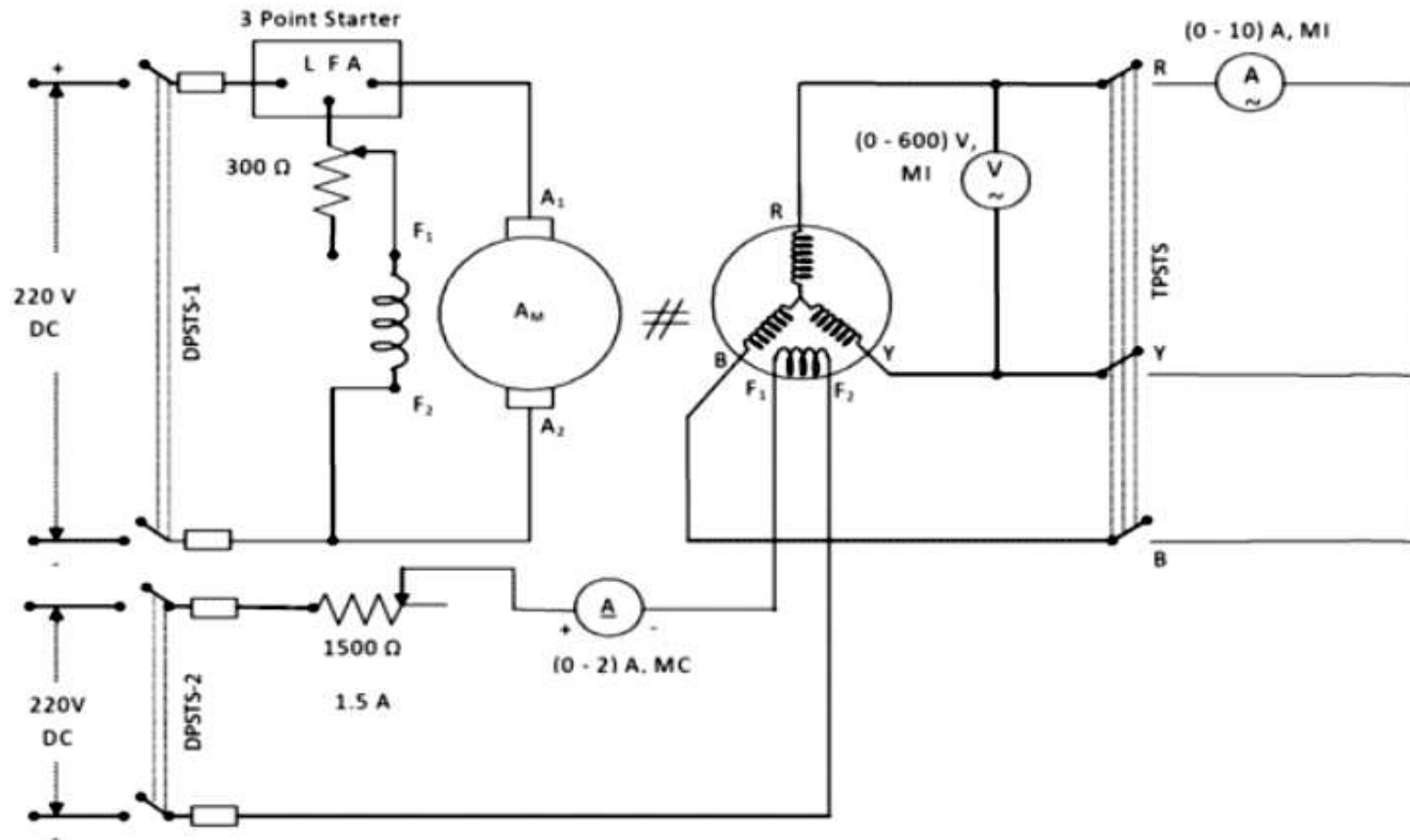

SYNCHRONOUS MACHINES

Indirect Methods of Voltage Regulation

Open circuit characteristics (OCC)

&

Short circuit characteristics (SCC)

Determination of Z_s from the graph

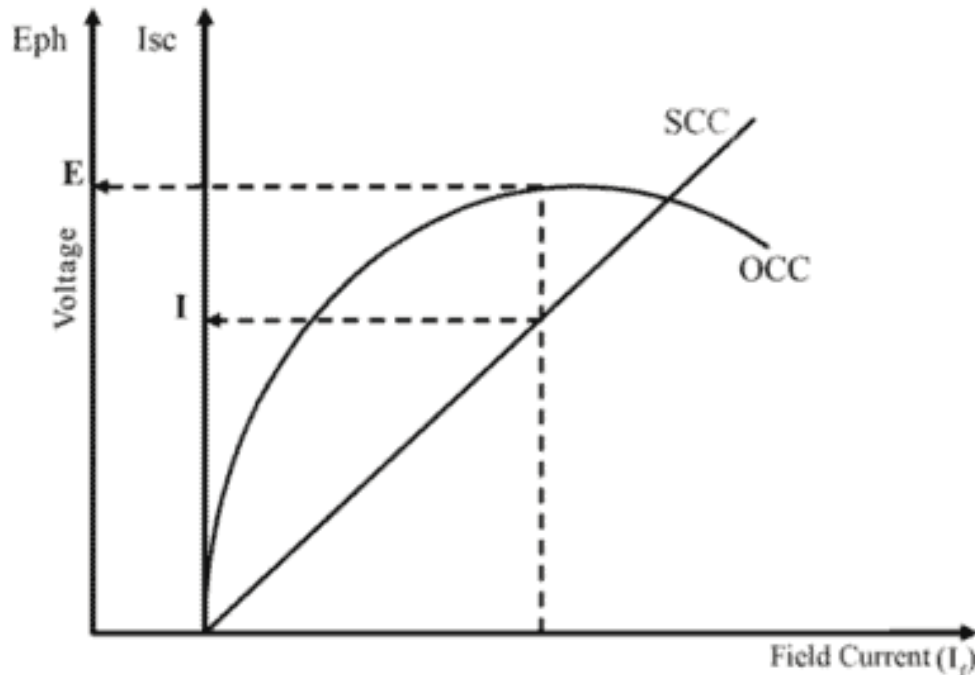

$$Z_s = \frac{V_{oc}}{I_{sc}}$$

$$X_s = \sqrt{Z_s^2 - R_a^2}$$



SYNCHRONOUS MACHINES

Indirect Methods of Voltage Regulation

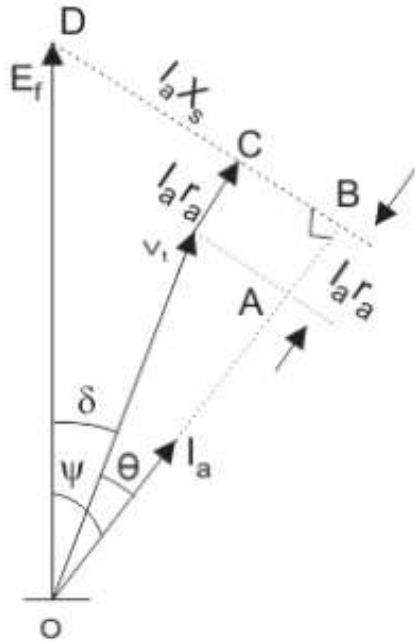

For Lagging Power factor,

$$E_{ph} = \sqrt{(V_{ph} \cos\phi + I_a R_a)^2 + (V_{ph} \sin\phi + I_a X_s)^2}$$

For Leading Power factor,

$$E_{ph} = \sqrt{(V_{ph} \cos\phi + I_a R_a)^2 + (V_{ph} \sin\phi - I_a X_s)^2}$$

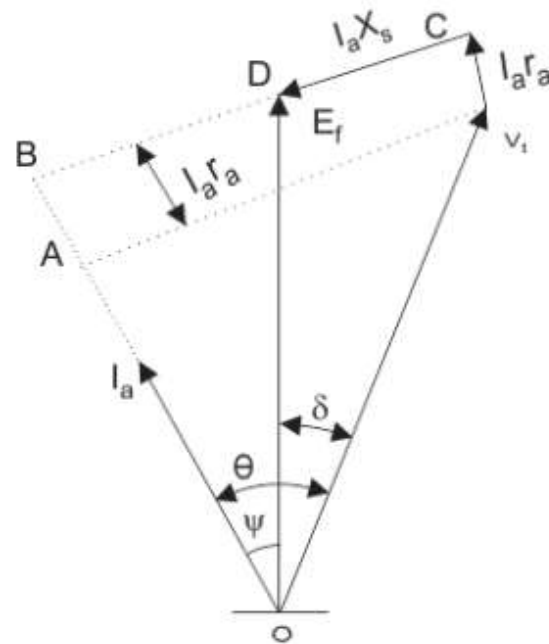

For Unity Power factor,

$$E_f^2 = (V_t + I_a \times r_a)^2 + (I_a \times X_s)^2$$

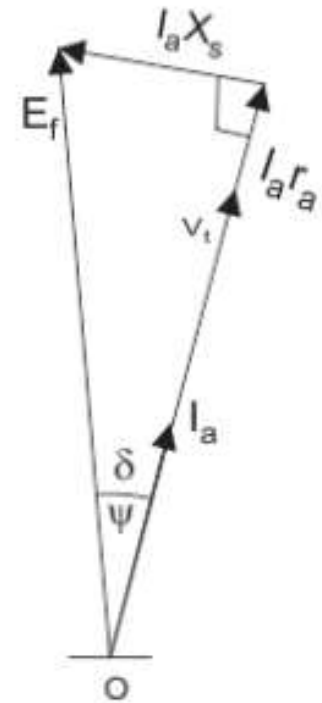

$$\text{Voltage Regulation} = \frac{E_{ph} - V_{ph}}{V_{ph}}$$



SYNCHRONOUS MACHINES

In a 50-kVA, star-connected, 440-V, 3-phase, 50-Hz alternator, the effective armature resistance is 0.25 ohm per phase. The synchronous reactance is 3.2 ohm per phase and leakage reactance is 0.5 ohm per phase. Determine at rated load and unity power factor :

(a) Internal e.m.f. E_a (b) no-load e.m.f. E_0 (c) percentage regulation on full-load (d) value of synchronous reactance which replaces armature reaction.

Solution. (a) The e.m.f. E_a is the vector sum of (i) terminal voltage V (ii) IR_a and (iii) IX_L here,

$$V = 440 / \sqrt{3} = 254 \text{ V}$$

F.L. output current at u.p.f. is □

$$= 50,000 / \sqrt{3} \times 440 = 65.6 \text{ A}$$

Resistive drop = $65.6 \times 0.25 = 16.4 \text{ V}$

Leakage reactance drop $IX_L = 65.6 \times 0.5 = 32.8 \text{ V}$

$$\therefore E_a = \sqrt{(V + IR_a)^2 + (IX_L)^2}$$

$$= \sqrt{(254 + 16.4)^2 + 32.8^2} = 272 \text{ volt}$$

Line value = $\sqrt{3} \times 272 = 471 \text{ volt.}$

(b) The no-load e.m.f. E_0 is the vector sum of (i) V (ii) IR_a and (iii) IX_s or is the vector sum of V and Z_s (Fig. 37.31).

$$\therefore E_0 = \sqrt{(V + IR_a)^2 + (IX_s)^2} = \sqrt{(254 + 16.4)^2 + (65.6 \times 3.2)^2} = 342 \text{ volt}$$

Line value = $\sqrt{3} \times 342 = 592 \text{ volt}$

(c) % age regulation 'up' = $\frac{E_0 - V}{V} \times 100 = \frac{342 - 254}{254} \times 100 = 34.65 \text{ per cent}$

(d) $X_a = X_s - X_L = 3.2 - 0.5 = 2.7 \Omega$

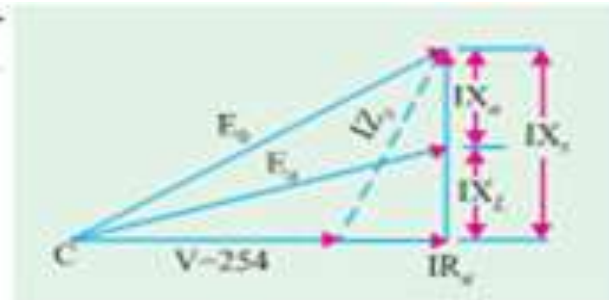

Fig. 37.31

TOPIC:

□ VOLTAGE REGULATION OF AN ALTERNATOR

**Lecture:
08**

SYNCHRONOUS MACHINES

Voltage Regulation of an Alternator

The voltage regulation of an alternator is defined as the change in its terminal voltage when full load is removed, keeping field excitation and speed constant, divided by the rated terminal voltage.

The value of the regulation not only depends on the load current but also on the power factor of the load.

For lagging and unity p.f. conditions there is always drop in the terminal voltage hence regulation values are always positive.

While for leading capacitive load conditions, the terminal voltage increases as load current increases. Hence regulation is negative in such cases.

The relationship between load current and the terminal voltage is called load characteristics of an alternator.

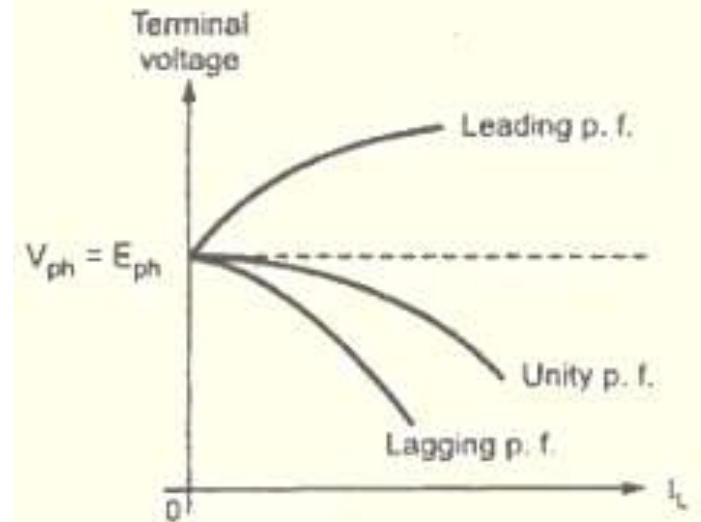

SYNCHRONOUS MACHINES

Voltage Regulation of an Alternator

The **Voltage Regulation** of a **Synchronous Generator** is the rise in voltage at the terminals when the load is reduced from full load rated value to zero, speed and field current remaining constant. It depends upon the power factor of the load. For unity and lagging power factors, there is always a voltage drop with the increase of load, but for a certain leading power, the full load voltage regulation is zero.

The voltage regulation is given by the equation shown below.

$$\text{Per Unit Voltage Regulation} \triangleq \frac{|E_a| - |V|}{|V|} \dots \dots \dots (1)$$

$$\text{Percentage Voltage Regulation} \triangleq \frac{|E_a| - |V|}{|V|} \dots \dots \dots (2)$$

Where,

$|E_a|$ is the magnitude of a generated voltage per phase

$|V|$ is the magnitude of rated terminal voltage per phase

In this case, the terminal voltage is the same for both full load and no load conditions. At lower leading power factors, the voltage rises with the increase of load, and the regulation is negative.



SYNCHRONOUS MACHINES

Voltage Regulation of an Alternator

Determination of Voltage Regulation

In the **case of small machines**, the regulation may be found by direct loading.

The alternator is driven at synchronous speed and the terminal voltage is adjusted to its rated value V .

The load is varied until the wattmeter and ammeter (connected for the purpose) indicate the rated values at desired p.f. Then the entire load is thrown off while the speed and field excitation are kept constant.

The open-circuit or no-load voltage E_0 is read.

$$\text{Percentage Voltage Regulation} = \left(\frac{|E_0| - |V|}{|V|} \right)$$

V = Rated terminal voltage

E_0 = No load induced e.m.f.



SYNCHRONOUS MACHINES

Voltage Regulation of an Alternator

Determination of Voltage Regulation

In the **case of large machines**, the cost of finding the regulation by direct loading becomes prohibitive.

Hence, other indirect methods are used as discussed below.

It will be found that all these methods differ chiefly in the way the no-load voltage E_0 is found in each case.

Methods OF Determining voltage regulation

1. Synchronous Impedance or E.M.F. Method.
2. The Ampere-turn or M.M.F. Method.
3. Zero Power Factor or Poitier Method.
4. A.S.A. method



SYNCHRONOUS MACHINES

Voltage Regulation of an Alternator

Methods to determine voltage regulation

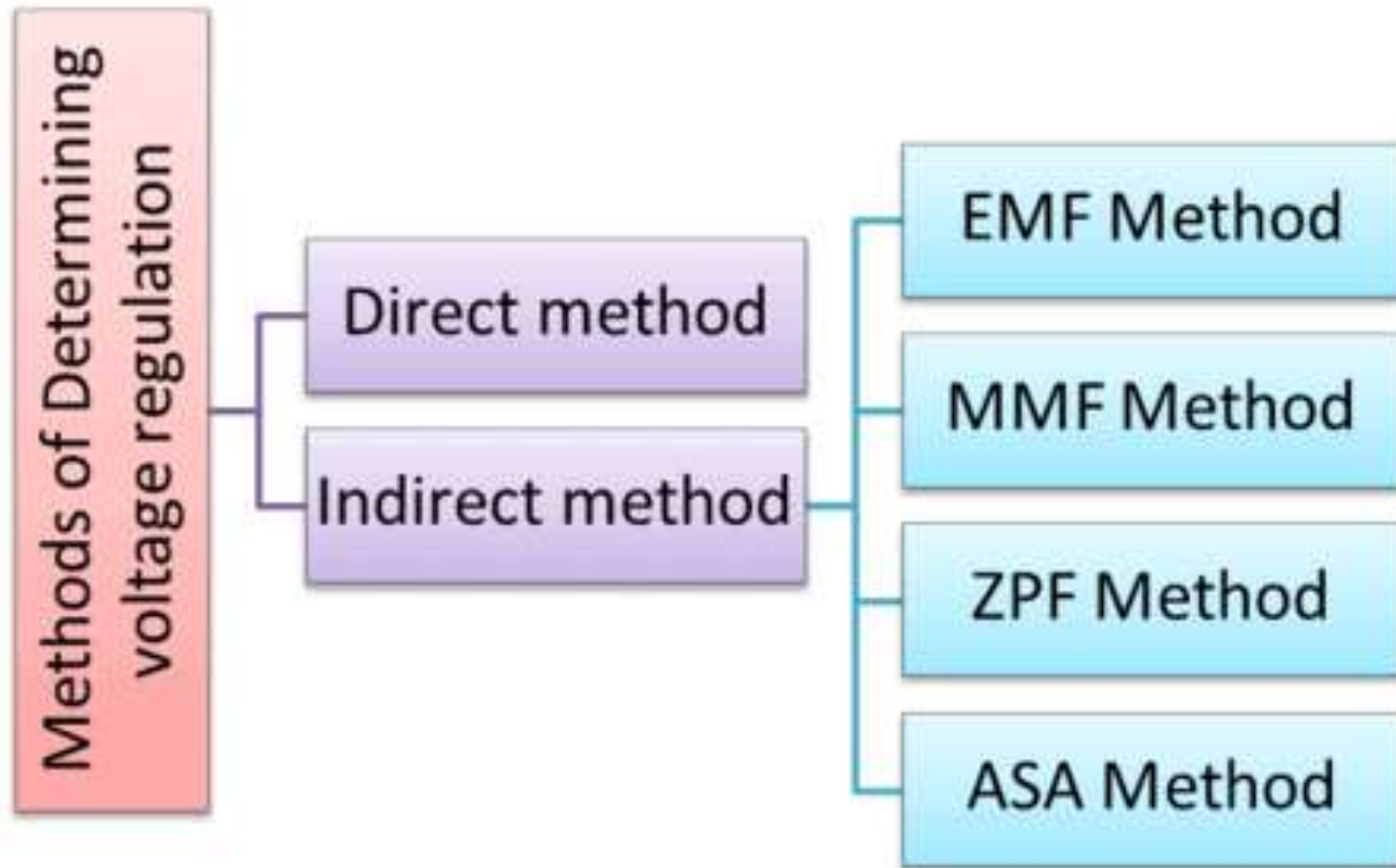

SYNCHRONOUS MACHINES

Voltage Regulation of an Alternator

Direct method of determining the voltage regulation

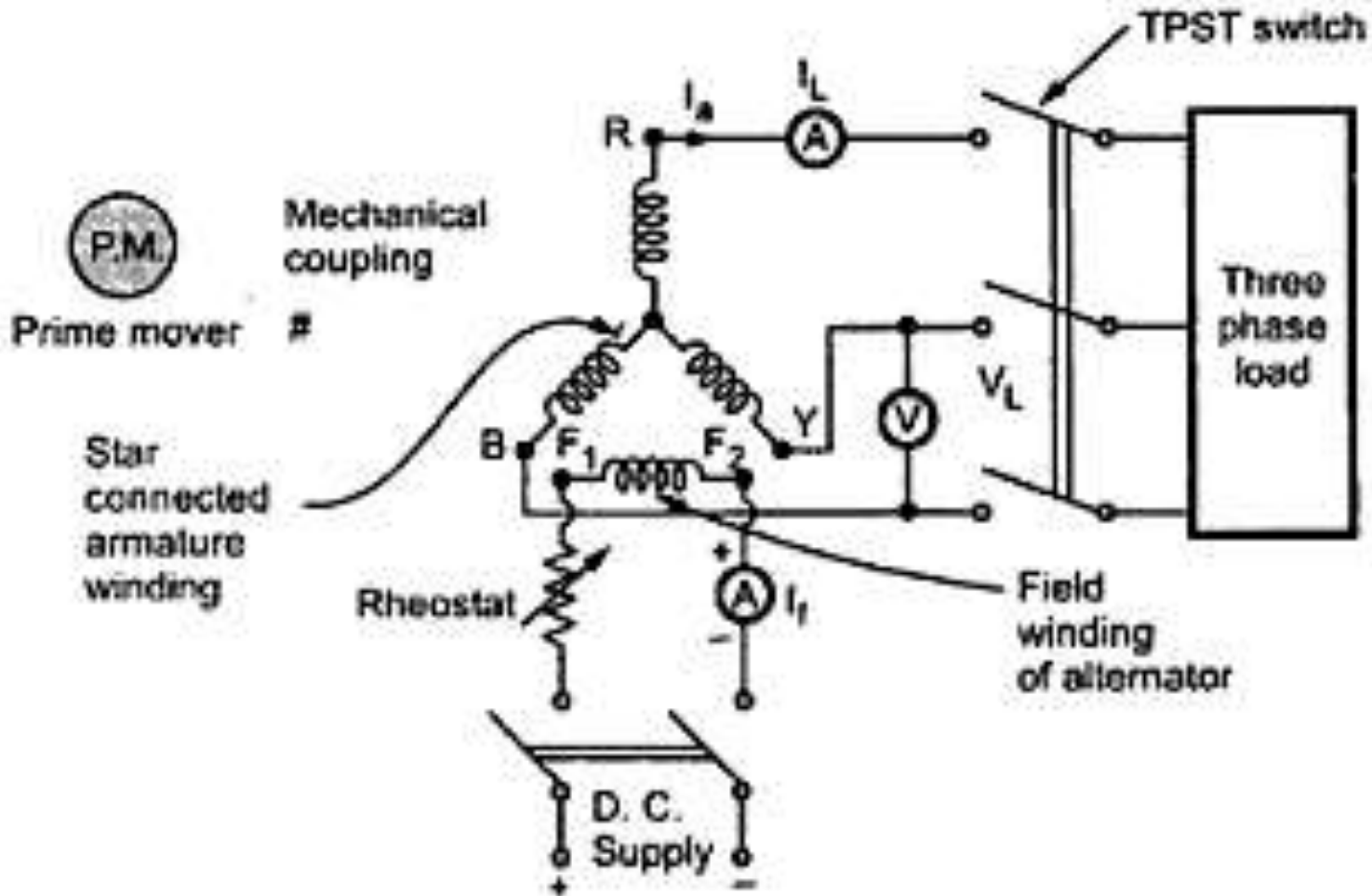

SYNCHRONOUS MACHINES

Voltage Regulation of an Alternator

Direct method of determining the voltage regulation

In this direct method, a three phase load is connected to star connected alternator with the help of Triple Pole Single Throw switch. The field winding of alternator is excited using an external DC supply. A rheostat is connected in series with the field winding, to control the flux produced in the field winding.

Adjust the rheostat of the field winding so that, to produce the rated terminal voltage. Close the load switch, apply the full load and measure the voltage at full load V .

Then the entire load is thrown off while the speed and field excitation are kept constant. The open circuit or no load voltage is measured and now the regulation can be determined from the below equation.

$$\text{Percentage Voltage Regulation} = \frac{E_0 - V}{V} * 100$$

But in the case of large machines, it becomes very difficult to determine the voltage regulation by direct loading method. So it is very important to switch over to the indirect methods of determination.



TOPIC:

**☐ SYNCHRONIZATION OF THREE
PHASE ALTERNATORS**

**Lecture:
07**

SYNCHRONOUS MACHINES

Synchronization of Three Phase Alternators

A stationary generator must not be connected to live Bus bars because the induced EMF is zero at standstill resulting in a short circuit.

The **Synchronization** procedure and the equipment for checking it are the same whether one alternator is to be connected in parallel with another alternator, or an alternator is to be connected to the infinite bus.

Before reconnecting the generator to the system in each time, it must be synchronized with parameters of the power system network.

An improper synchronization can affect the healthy power system and results in electrical and mechanical transients that can damage the prime mover, generator, transformers and other power system components.



SYNCHRONOUS MACHINES

Synchronization of Three Phase Alternators

What is Synchronization of Generators

The process of matching parameters such as voltage, frequency, phase angle, phase sequence and waveform of alternator (generator) or other source with a healthy or running power system is called synchronization.

Generator cannot deliver power to electric power system unless its voltage, frequency and other parameters are exactly matched with the network. Synchronization is accomplished by controlling the exciter current and the engine speed of the generator

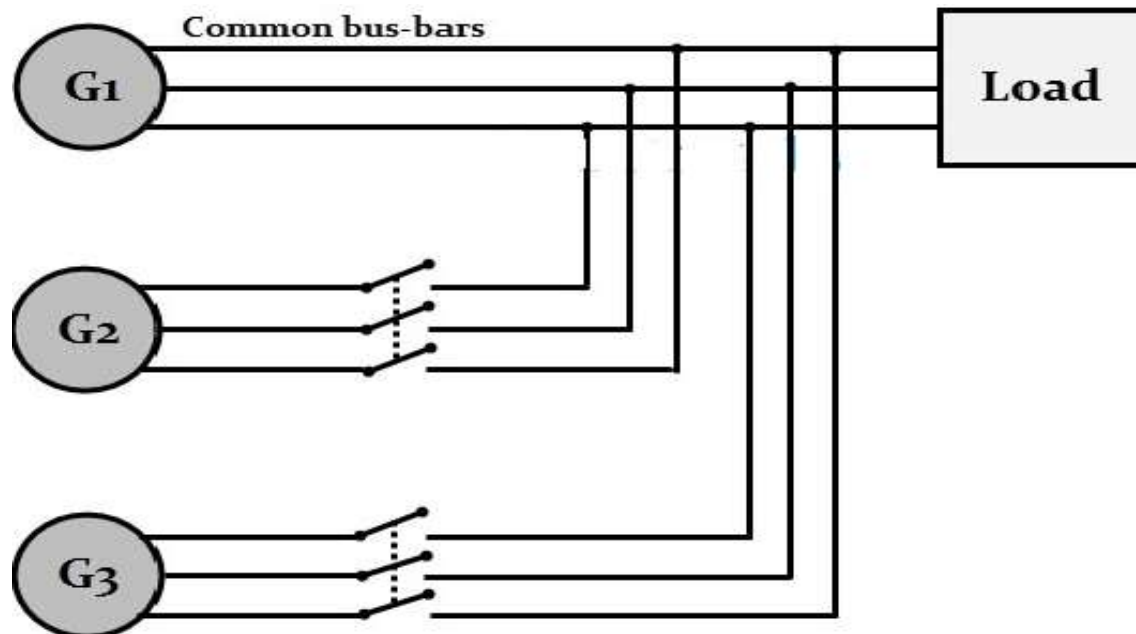

SYNCHRONOUS MACHINES

Synchronization of Three Phase Alternators

Need of Synchronization

The need for synchronization arrives, particularly when two or more alternators are working together to supply the power to the load. This is because electrical loads are not constant and they vary with time and hence they necessitate the interconnection of two or more alternators operating in parallel to supply larger loads.

Synchronization matches various parameters of one alternator (or generator) to another alternator or to the bus bar. The process of synchronization is also called as paralleling of alternators.

- 1. Reliability**
- 2. Continuity of Service**
- 3. Load Requirements**
- 4. High Efficiency**
- 5. Expanded Capacity**



SYNCHRONOUS MACHINES

Synchronization of Three Phase Alternators

Conditions for Synchronization

There are certain requirements that must be met for successful paralleling of alternators. The following conditions must be met in order to synchronize a generator to the grid or with other generators.

- 1. Phase Sequence**
- 2. Voltage Magnitude**
- 3. Frequency**
- 4. Phase Angle**



SYNCHRONOUS MACHINES

Synchronization of Three Phase Alternators

Techniques for Synchronization

There are different techniques being available for the synchronization of alternators. The primary purpose of these techniques is to check all four conditions discussed above. The common methods used for synchronizing the alternators are given below.

1. Three Dark Lamps Method
2. Two Bright, One Dark Method
3. Synchroscope Method



SYNCHRONOUS MACHINES

Synchronization of Three Phase Alternators

Three Dark Lamps Method

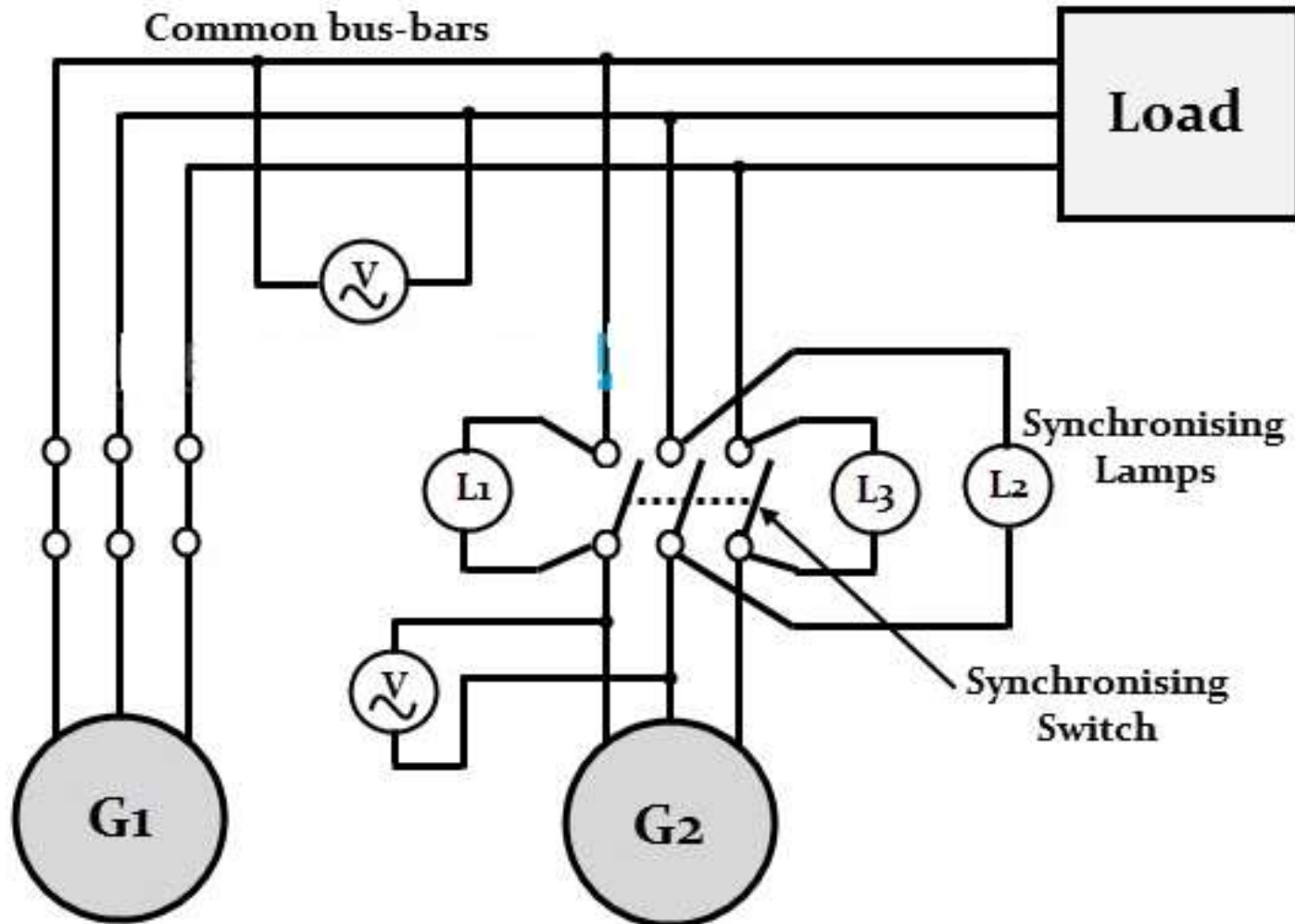

SYNCHRONOUS MACHINES

Synchronization of Three Phase Alternators

Advantages of the Dark Lamp Method

This method is cheaper.

The correct phase sequence is easily determined.

Disadvantages of the Dark Lamp Method

The lamp becomes dark at about half of its rated voltage. Hence, it is possible that the synchronizing switch might be switched off even when there is a phase difference between the machine.

The filament of the lamp might burn out.

The flicker of the lamps does not indicate that which lamp has the higher frequency.



SYNCHRONOUS MACHINES

Synchronization of Three Phase Alternators

Two Bright and One Dark Lamp Method

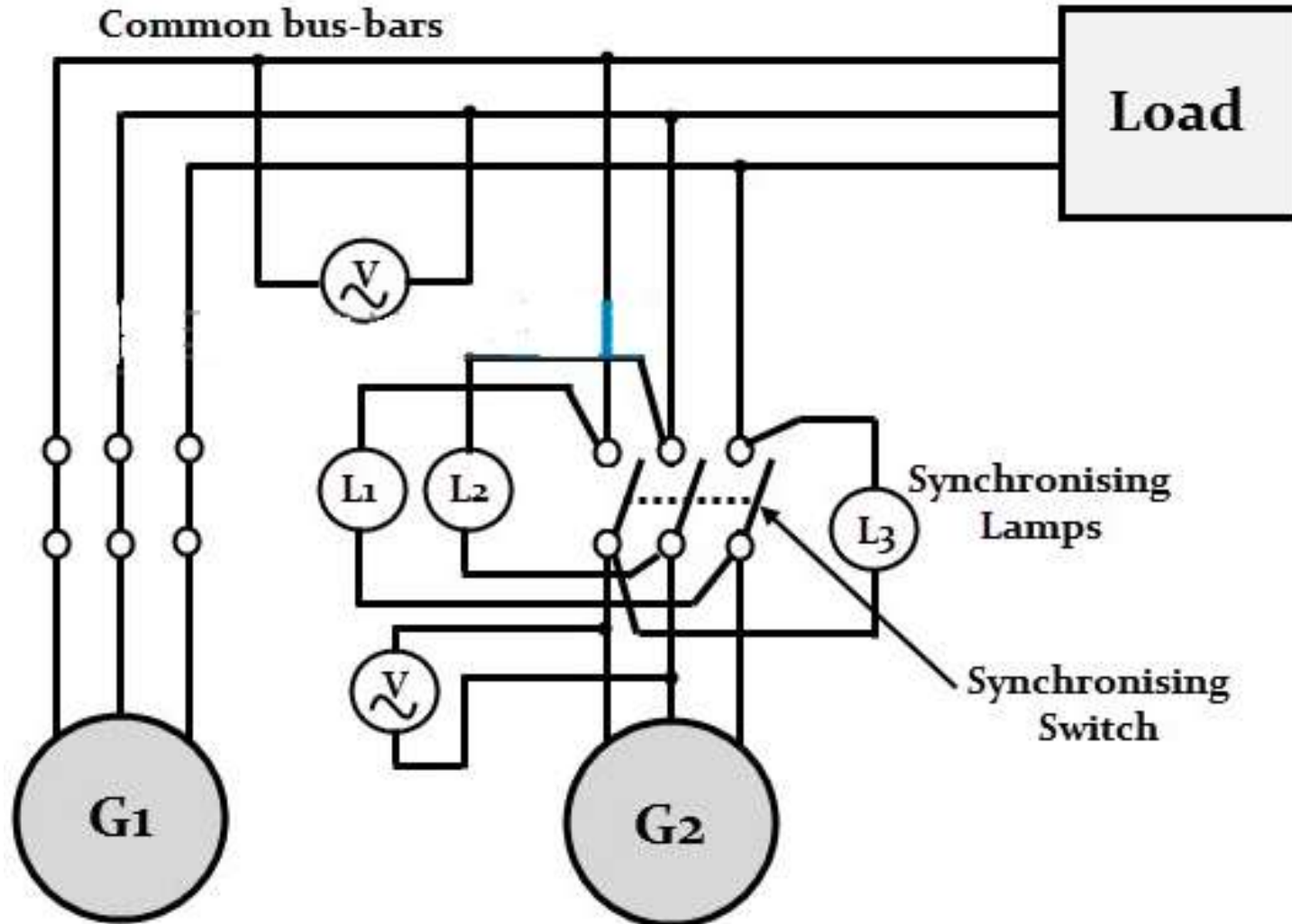

SYNCHRONOUS MACHINES

Synchronization of Three Phase Alternators

Synchroscope Method

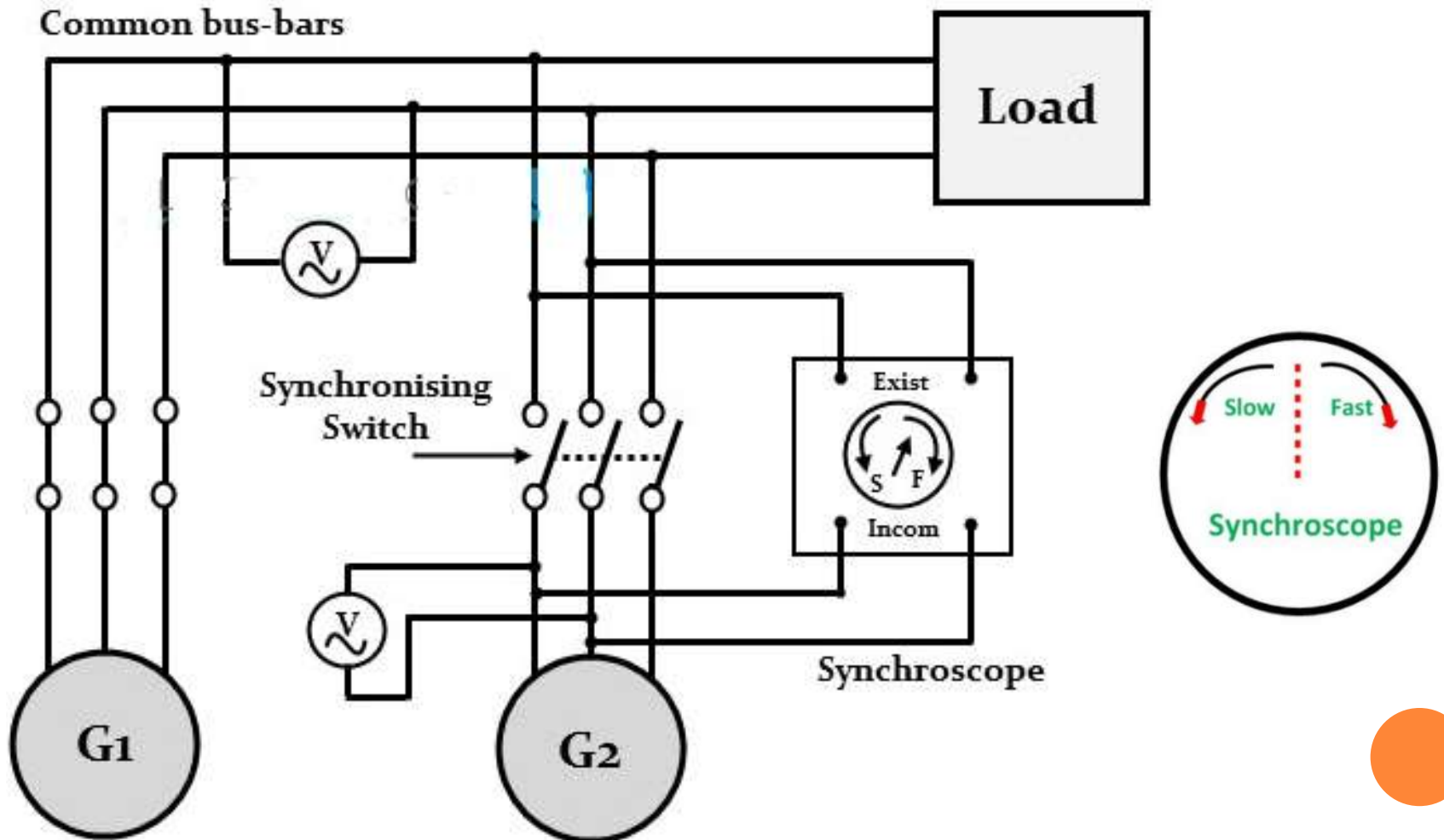

TOPIC:

- **OPEN CIRCUIT CHARACTERISTICS, SHORT CIRCUIT CHARACTERISTICS OF ALTERNATOR AND DETERMINATION OF SYNCHRONOUS REACTANCE.**

**Lecture:
06**

SYNCHRONOUS MACHINES

OPEN CIRCUIT CHARACTERISTICS, SHORT CIRCUIT CHARACTERISTICS OF ALTERNATOR

Open Circuit Test and Short Circuit Test are performed on a Synchronous Machine to find out the parameters of Synchronous Machine and hence to have an idea of their performance. Open Circuit Test of Synchronous Machine is also called No Load, Saturation or Magnetizing Characteristics

For getting the Open Circuit Characteristics of Synchronous Machine, the alternator is first driven at its rated speed and the open terminal voltage i.e. voltage across the armature terminal is noted by varying the field current. Thus Open Circuit Characteristic or OCC is basically the plot between the armature terminal voltage E_f versus field current I_f while keeping the speed of rotor at rated value. It shall be noted that for OCC, the final value of E_f shall be 125% of the rated voltage.

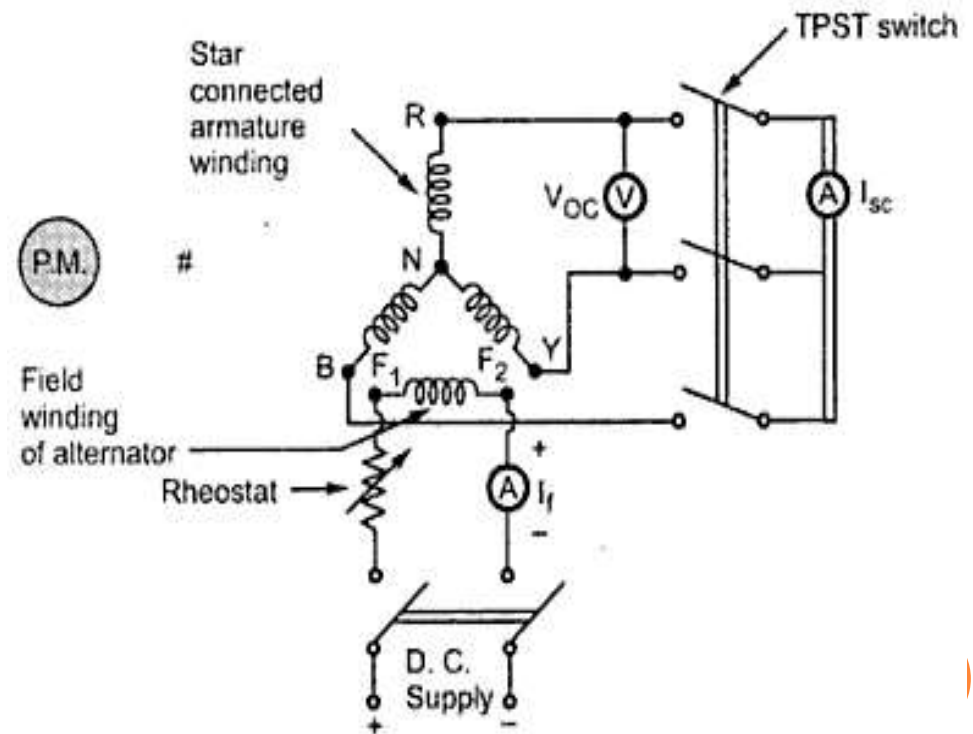

SYNCHRONOUS MACHINES

OPEN CIRCUIT CHARACTERISTICS, SHORT CIRCUIT CHARACTERISTICS OF ALTERNATOR

In the **open circuit test** for determining the synchronous impedance, the alternator is running at the rated synchronous speed, and the load terminals are kept open. This means that the loads are disconnected, and the field current is set to zero. The circuit diagram is shown below.

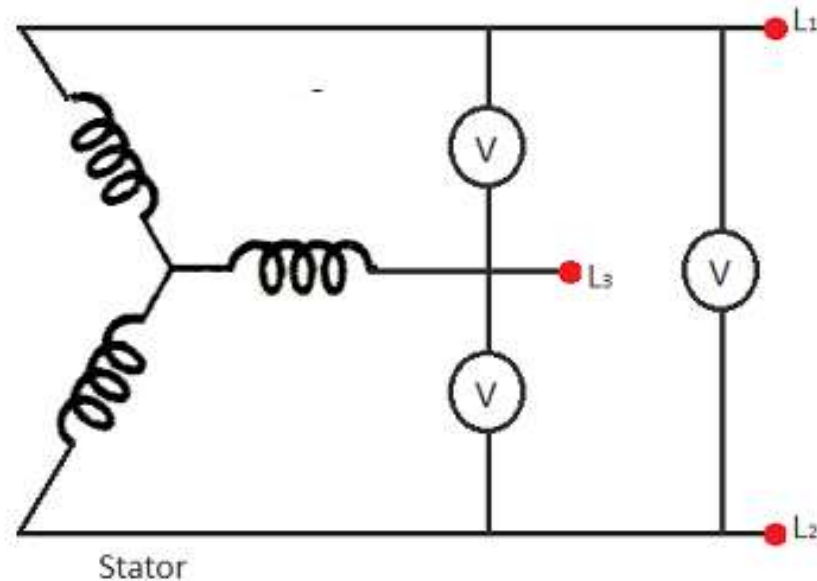
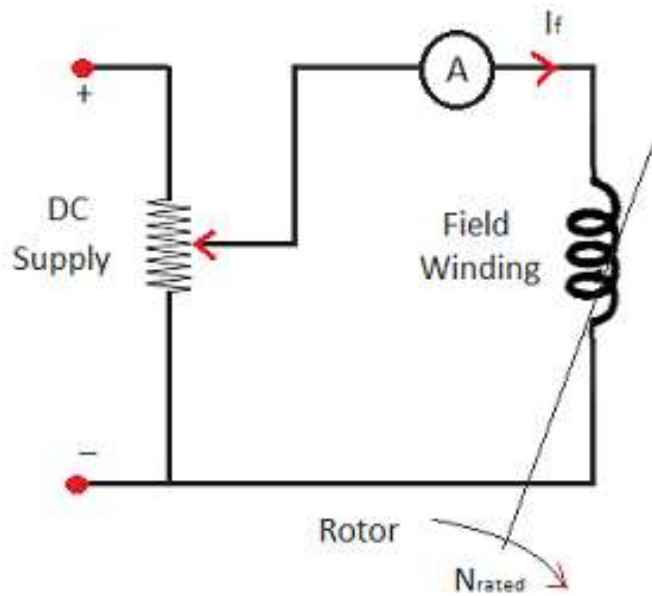

SYNCHRONOUS MACHINES

OPEN CIRCUIT CHARACTERISTICS, SHORT CIRCUIT CHARACTERISTICS OF ALTERNATOR

After setting the field current to zero, the field current is gradually increased step by step. The terminal voltage E_t is measured at each step. The excitation current may be increased to get 25% more than the rated voltage. A graph is drawn between the open circuit phase voltage $E_p = E_t/\sqrt{3}$ and the field current I_f . The curve so obtained is called Open Circuit Characteristic (O.C.C). The shape is same as normal magnetization curve. The linear portion of the O.C.C is extended to form an air gap line.

The **Open Circuit Characteristic (O.C.C)** and the air gap line is shown in the figure below.

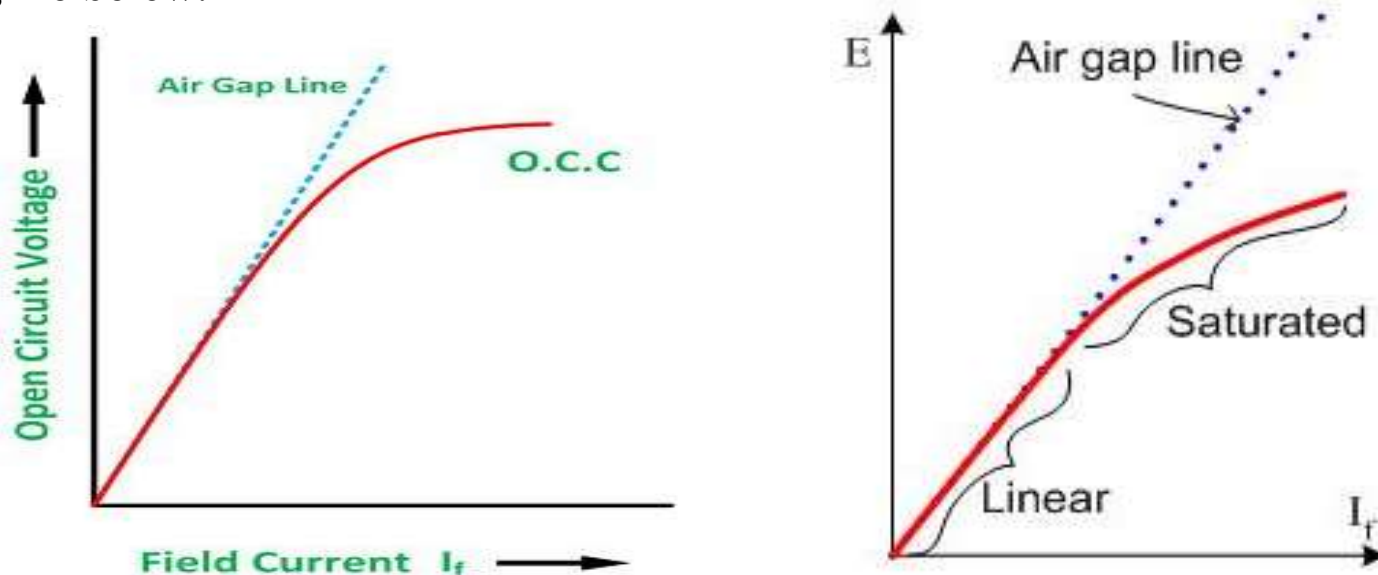

SYNCHRONOUS MACHINES

OPEN CIRCUIT CHARACTERISTICS, SHORT CIRCUIT CHARACTERISTICS OF ALTERNATOR

The field current should first be decreased to zero before starting the alternator. Each ammeter should have a range greater than the rated full load value. The alternator is then run at synchronous speed. Same as in an open circuit test that the field current is increased gradually in steps and the armature current is measured at each step. The field current is increased to get armature currents up to 150% of the rated value.

In the **short circuit test**, the armature terminals are shorted through three ammeters as shown in the figure below.

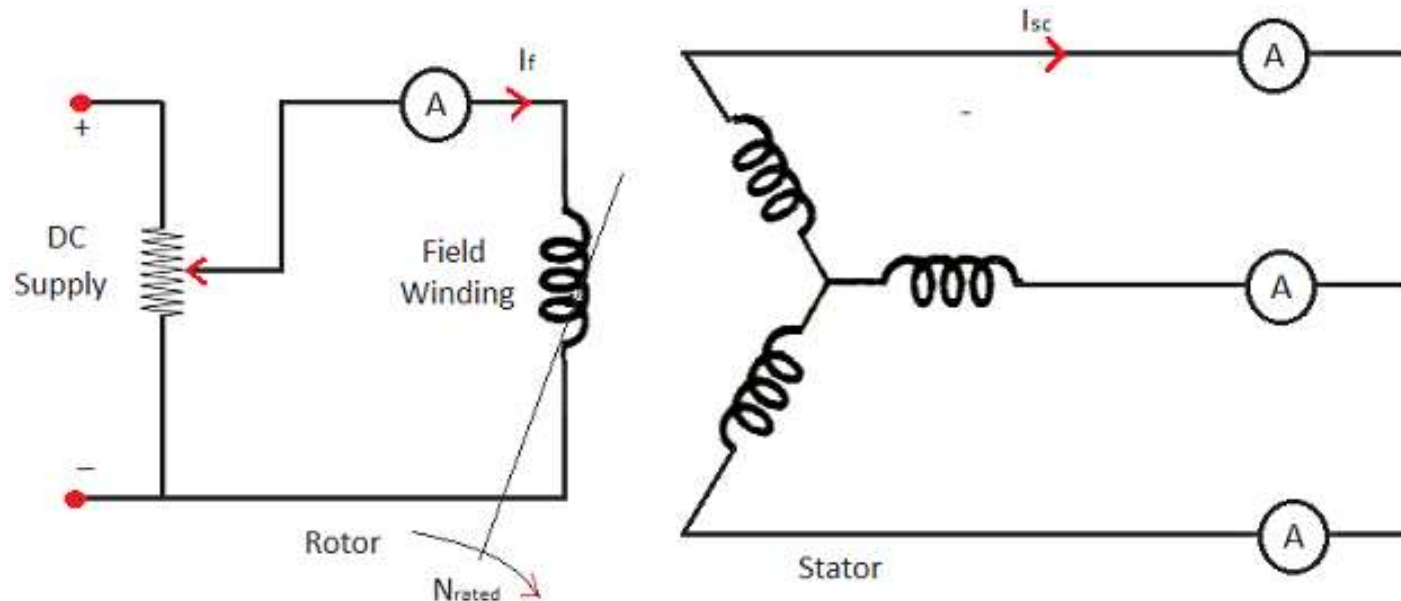

SYNCHRONOUS MACHINES

OPEN CIRCUIT CHARACTERISTICS, SHORT CIRCUIT CHARACTERISTICS OF ALTERNATOR

The value of field current I_f and the average of three ammeter readings at each step is taken. A graph is plotted between the armature current I_a and the field current I_f . The characteristic so obtained is called **Short Circuit Characteristic (S.C.C)**. This characteristic is a straight line as shown in the figure below.

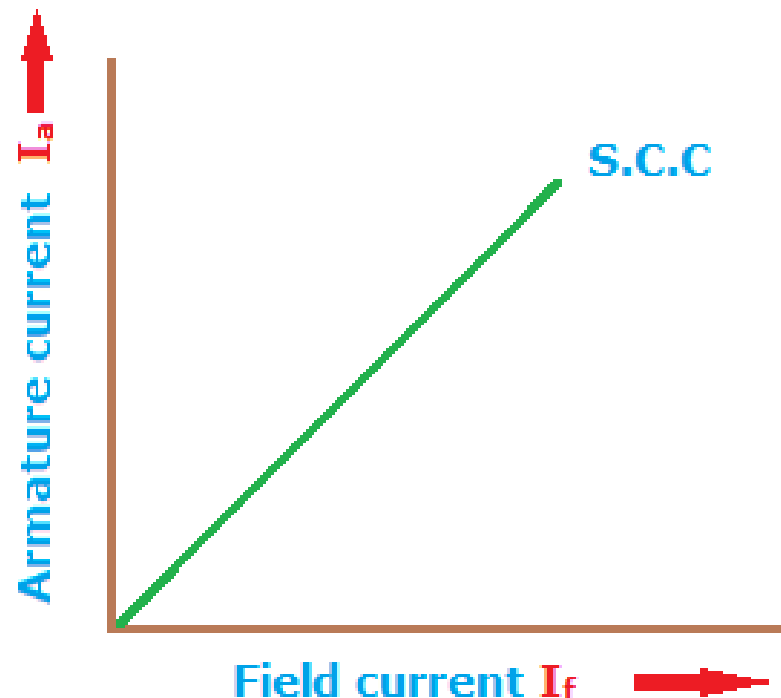

SYNCHRONOUS MACHINES

OPEN CIRCUIT CHARACTERISTICS, SHORT CIRCUIT CHARACTERISTICS OF ALTERNATOR

Calculation of Z_s

The open circuit characteristic (O.C.C.) and short circuit characteristic (S.C.C.) are drawn on the same curve sheet. Determine the value of I_{sc} and field current that gives the rated alternator voltage per phase. the synchronous impedance Z_s will then be equal to the open circuit voltage divided by the short circuit current at the field current which gives the rated e.m.f. per phase.

$$Z_s = \frac{\text{Open-circuit voltage per phase}}{\text{short-circuit armature current}}$$

For the same value of field current. The synchronous reactance is found as follows.

$$X_s = \sqrt{Z_s^2 - R_a^2}$$

In figure , consider the field current $I_f = OA$ that the produces rated alternator voltage per phase. corresponding to this field current the open circuit voltage is AB.

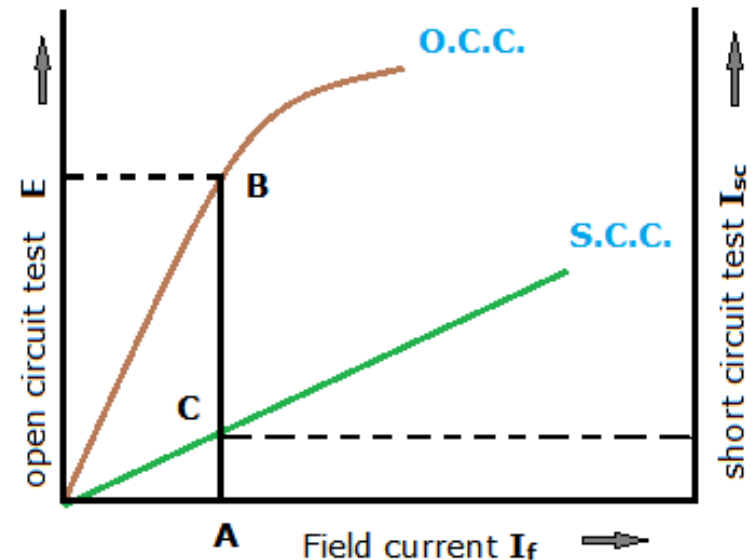

$$Z_s = \frac{AB \text{ (in volts)}}{AC \text{ (in amperes)}}$$

SYNCHRONOUS MACHINES

OPEN CIRCUIT CHARACTERISTICS, SHORT CIRCUIT CHARACTERISTICS OF ALTERNATOR

DC resistance test

In this test, it is assumed that the alternator is star connected with the DC field winding open as shown in the circuit diagram below.

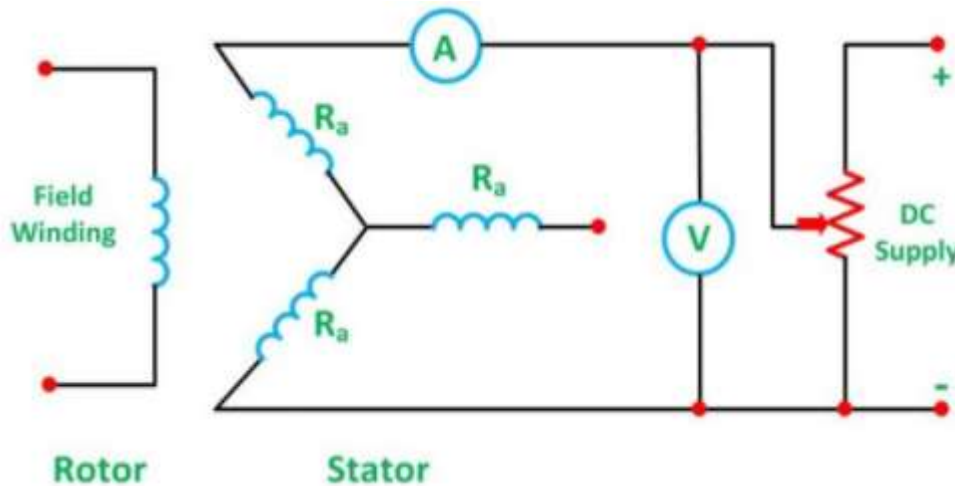

It measures the DC resistance between each pair of terminals either by using an ammeter – voltmeter method or by using the Wheatstone's bridge. The average of three sets of resistance value R_t is taken. The value of R_t is divided by 2 to obtain a value of DC resistance per phase. Since the effective AC resistance is larger than the DC resistance due to skin effect. Therefore, the effective AC resistance per phase is obtained by multiplying the DC resistance by a factor 1.20 to 1.75 depending on the size of the machine. A typical value to use in the calculation would be 1.25

TOPIC:

- PHASOR DIAGRAMS OF ALTERNATOR AT LAGGING, LEADING AND UNITY P.F. LOADS.

**Lecture:
05**

SYNCHRONOUS MACHINES

Phasor diagrams of alternator at lagging, leading and unity p.f. loads.

The phasor diagram is a very significant factor of the power system analysis. As the output of the synchronous generator is alternating current, so it can easily be explained by the phasor diagrams. If we draw the output voltage and current in such a geometrically way that they show some relation among them, the resultant diagram called a **phasor diagram**.

In the electrical power system, there are three main types of load first one is resistive, the second one is capacitive and the third one is inductive.

We will connect all these three loads with the synchronous generator and will see their effect and will draw their phasor diagram.



SYNCHRONOUS MACHINES

Phasor diagrams of alternator at lagging, leading and unity p.f. loads.

In the present article we are going to discuss one of the easiest methods of making the phasor diagram for synchronous generator. Now, let us write the various notations for each quantity at one place, this will help us to understand the phasor diagram more clearly. In this phasor diagram we are going to use:

E_f which denotes excitation voltage

V_t which denotes terminal voltage

I_a which denotes the armature current

θ which denotes the phase angle between V_t and I_a

ψ which denotes the angle between the E_f and I_a

δ which denotes the angle between the E_f and V_t

r_a which denotes the armature per phase resistance



SYNCHRONOUS MACHINES

Phasor diagrams of alternator at lagging, leading and unity p.f. loads.

In order to draw the phasor diagram we will use V_t as reference. Consider these two important points which are written below:

1. We already know that if a machine is working as a synchronous generator then direction of I_a will be in phase to that of the E_f .
2. Phasor E_f is always ahead of V_t .

These two points are necessary for making the **phasor diagram of synchronous generator**. Given below is the phasor diagram of synchronous generator:

In this phasor diagram we have drawn the direction of the I_a is in phase with that of the E_f as per the point number 1 mentioned above. Now let us derive expression for the excitation emf in each case. We have three cases that are written below:

- Generating operation at lagging power factor.
- Generating operation at unity power factor.
- Generating operation at leading power factor.



SYNCHRONOUS MACHINES

Phasor diagrams of alternator at lagging, leading and unity p.f. loads.

(A) Generating operation at lagging power factor:

We can derive the expression for the E_f by first taking the component of the V_t in the direction of L . Component of V_t in the direction of L is $V_t \cos \theta$, hence the total voltage drop is $(V_t \cos \theta + I_a r_a)$ along the L . Similarly we can calculate the voltage drop along the direction perpendicular to L . The total voltage drop perpendicular to L is $(V_t \sin \theta + I_a X_s)$. With the help of triangle BOD in the first phasor diagram we can write the expression for E_f as

$$E_f^2 = (V_t \cos \theta + I_a \times r_a)^2 + (V_t \sin \theta + I_a \times X_s)^2$$

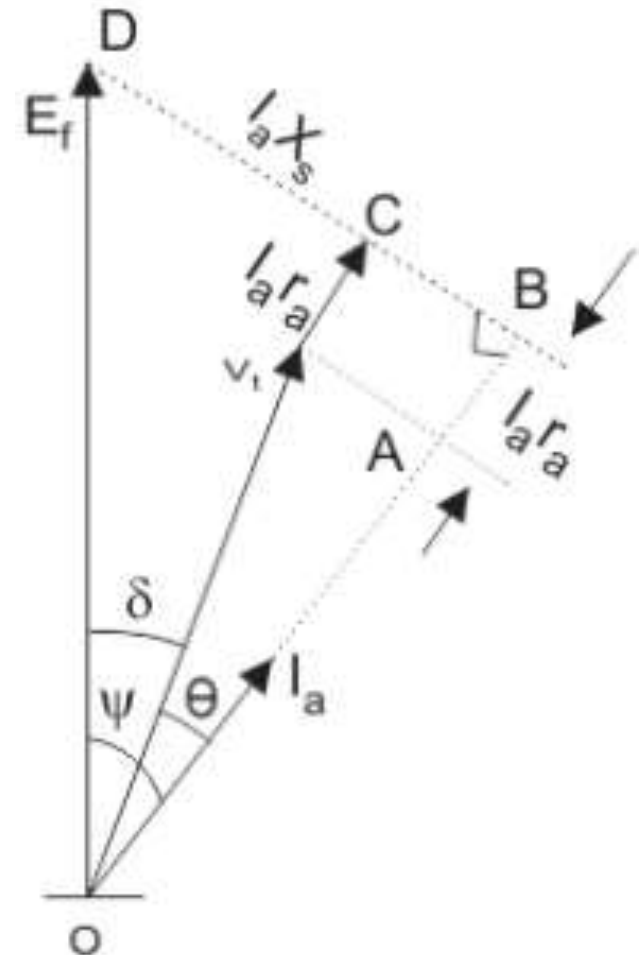

SYNCHRONOUS MACHINES

Phasor diagrams of alternator at lagging, leading and unity p.f. loads.

(B) Generating operation at unity power factor

Here also we can derive the expression for the E_f by first taking the component of the V_t in the direction of I_a . But in this case the value of theta is zero and hence we have $\psi = \delta$.

With the help of triangle BOD in the second phasor diagram we can directly write the expression for E_f as

$$E_f^2 = (V_t + I_a \times r_a)^2 + (I_a \times X_s)^2$$

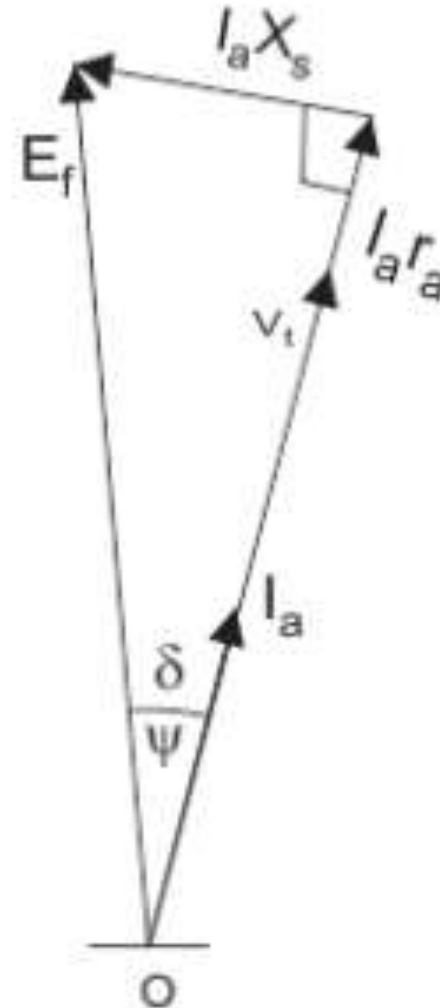

SYNCHRONOUS MACHINES

Phasor diagrams of alternator at lagging, leading and unity p.f. loads.

(C) Generating operation at leading power factor

Component in the direction of \underline{L} is $V_t \cos \theta$. As the direction of I_a is same to that of the V_t thus the total voltage drop is $(V_t \cos \theta + I_a r_a)$. Similarly we can write expression for the voltage drop along the direction perpendicular to \underline{L} . The total voltage drop comes out to be $(V_t \sin \theta - I_a X_s)$. With the help of triangle BOD in the first phasor diagram we can write the expression for E_f as

$$E_f^2 = (V_t \cos \theta + I_a \times r_a)^2 + (V_t \sin \theta - I_a \times X_s)^2$$

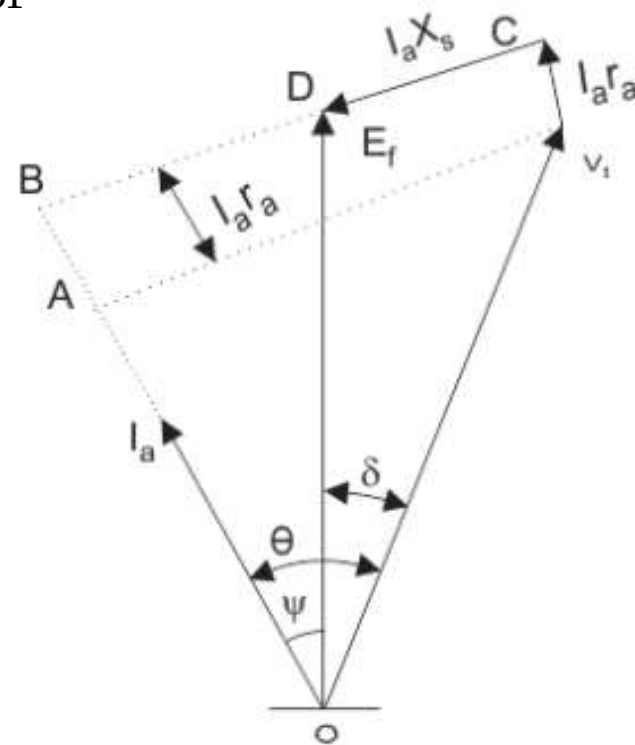

TOPIC:

**□ PARALLEL OPERATION OF
ALTERNATOR**

**Lecture:
04**



SYNCHRONOUS MACHINES

Parallel Operation of Alternator

Electric Power system are interconnected for economy and reliable operation. Interconnection of ac power system requires synchronous generator to operate in parallel with each other. In generating stations, two or more generators are connected in parallel. In an interconnected system forming a grid the alternator are located at different places. they are connected in parallel by means of transformers and transmission line. Under normal operating conditions all the alternator and synchronous motors in an interconnected system operate in synchronism with each other.

An arrangement of generators for parallel operation enables a plant engineer to adjust the machines for optimum operating efficiency and greater reliability's the load increases beyond the generated capacity of the connected units, additional generators are parallel to carry the load. Similarly, if the load demand decreases, one or more machines are taken off the line as per the requirement. It allows the units to operate at a higher efficiency.



SYNCHRONOUS MACHINES

Parallel Operation of Alternator

When the load on a system exceeds the amount of power that a single or existing number of generators can deliver, an additional generator is connected to the system to deliver required power. This method of adding an alternator in the existing system is called 'parallel operation of alternators'.



SYNCHRONOUS MACHINES

Parallel Operation of Alternator

When the load on a system exceeds the amount of power that a single or existing number of generators can deliver, an additional generator is connected to the system to deliver required power. This method of adding an alternator in the existing system is called 'parallel operation of alternators'. It is essential to know that the incoming alternator must be paralleled such that each machine is supplying a proportionate amount of active and reactive power to the common load. For which certain rules are to be kept in mind.

Interconnection of the electric power systems is essential from the economical point of view and also for reliable and **Parallel Operation**. Interconnection of AC power systems requires synchronous generators to operate in **parallel** with each other. In generating stations, two or more generators are connected in parallel. The alternators are located at different locations forming a **grid** connected system



SYNCHRONOUS MACHINES

Parallel Operation of Alternator

Reasons of Parallel Operation

Alternators are operated in parallel for the following reasons:

1. Several alternators can supply a bigger load than a single alternator.
2. One or more alternators may shut down during the period of light loads. Thus, the remaining alternator operates at near or full load with greater efficiency.
3. When one machine is taken out of service for its scheduled maintenance and inspection, the remaining machines maintain the continuity of the supply.

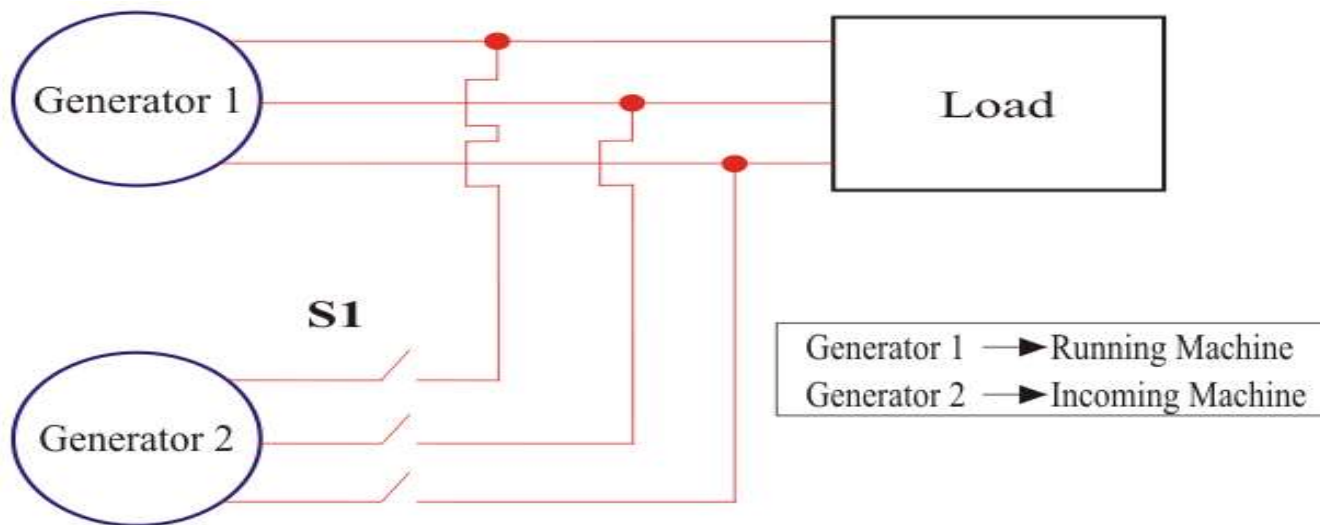

SYNCHRONOUS MACHINES

Parallel Operation of Alternator

Reasons of Parallel Operation

4. If there is a breakdown of the generator, there is no interruption of the power supply.
5. Number of machines can be added with disturbing the initial installation according to the requirement to fulfill the increasing future demand of the load.
6. Parallel operation of the alternator, reduces the operating cost and the cost of energy generation.
7. It ensures the greater security of supply and enables overall economic generation.



SYNCHRONOUS MACHINES

Parallel Operation of Alternator

Necessary Conditions for Parallel Operation of the Alternator

Most synchronous machines will operate in parallel with other synchronous machines. The process of connecting one machine in parallel with another machine or with an Infinite Bus bar system is known as **Synchronizing**. The machine carrying load is known as **Running Machines** while the alternator which is to be connected in parallel with the system is known as the **Incoming machine**.

The following condition should be satisfied for parallel operation are as follows:-

1. The phase sequence of the Busbar voltages and the incoming machine voltage must be the same.
2. The Busbar voltages and the incoming machine terminal voltage must be in phase.
3. The terminal voltage of the incoming machine and the alternator which is to be connected in parallel or with the Busbar voltage should be equal.
4. The frequency of the generated voltage of the incoming machine and the frequency of the voltage of the Busbar should be equal.

SYNCHRONOUS MACHINES

Parallel Operation of Alternator

Advantages of Parallel Operating Alternators

1. When there is maintenance or an inspection, one machine can be taken out from service and the other alternators can keep up for the continuity of supply.
2. Load supply can be increased.
3. During light loads, more than one alternator can be shut down while the other will operate in nearly full load.
4. High efficiency.
5. The operating cost is reduced.
6. Ensures the protection of supply and enables cost-effective generation.
7. The generation cost is reduced.
8. Breaking down of a generator does not cause any interruption in the supply.
9. Reliability of the whole power system increases.



SYNCHRONOUS MACHINES

Parallel Operation of Alternator

General Procedure for Paralleling Alternators

These two machines are about to synchronize for supplying power to a load. Generator 2 is about to parallel with the help of a switch, S1. This switch should never be closed without satisfying the above conditions.

1. To make the terminal voltages equal. This can be done by adjusting the terminal voltage of incoming machine by changing the field current and make it equal to the line voltage of running system using voltmeters.

2. There are two methods to check the phase sequence of the machines. They are as follows

- First one is using a Synchroscope.
- Second method is three lamp method.

3. Next, we have to check and verify the incoming and running system frequency. It should be nearly the same. This can be done by inspecting the frequency of dimming and brightening of lamps.

4. When the frequencies are nearly equal, the two voltages (incoming alternator and running system) will alter the phase gradually. These changes can be observed and the switch, S1 can be made closed when the phase angles are equal.

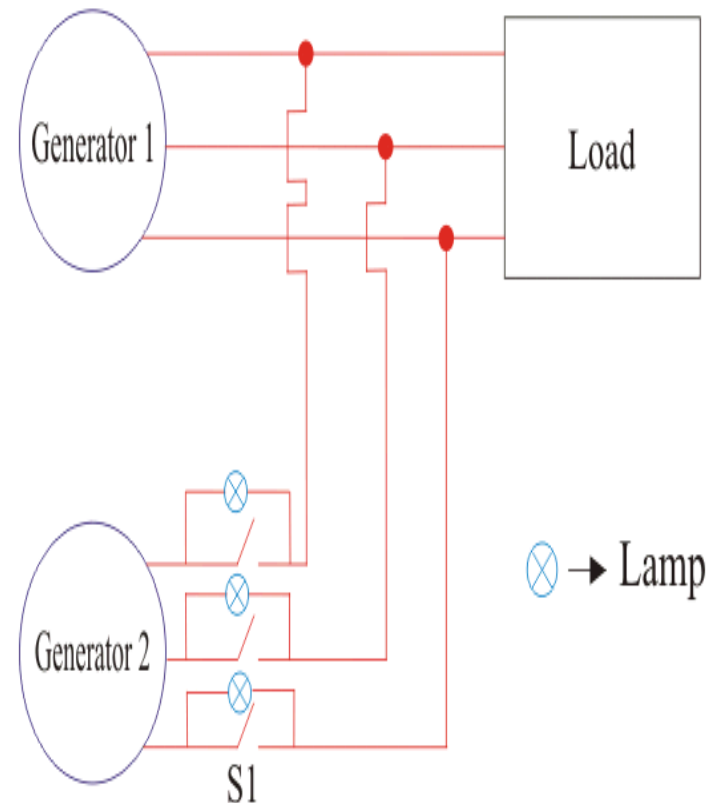

TOPIC:

□ REPULSION MOTOR

**Lecture:
11**



SINGLE PHASE INDUCTION MOTOR

REPULSION MOTOR

A motor is an electrical device that converts electrical input into mechanical output, where electrical input can be in current or voltage form and the mechanical output can be in torque or force form. Motor consist of two main parts namely stator and rotor, where the stator is a stationary part of the motor and the rotor is a rotating part of the motor. A motor that works on the principle of repulsion is known as a repulsion motor, where the repulsion takes place between two magnetic fields of either stator or a rotor. Repulsion motor is a single-phase motor.

What is Repulsion Motor

A repulsion motor is a single-phase electric motor that operates by providing input AC (alternating current). The main application of repulsion motor is electric trains. It starts as a repulsion motor and runs as an induction motor, where the starting torque should be high for repulsion motor and very good running characteristics for induction motor.

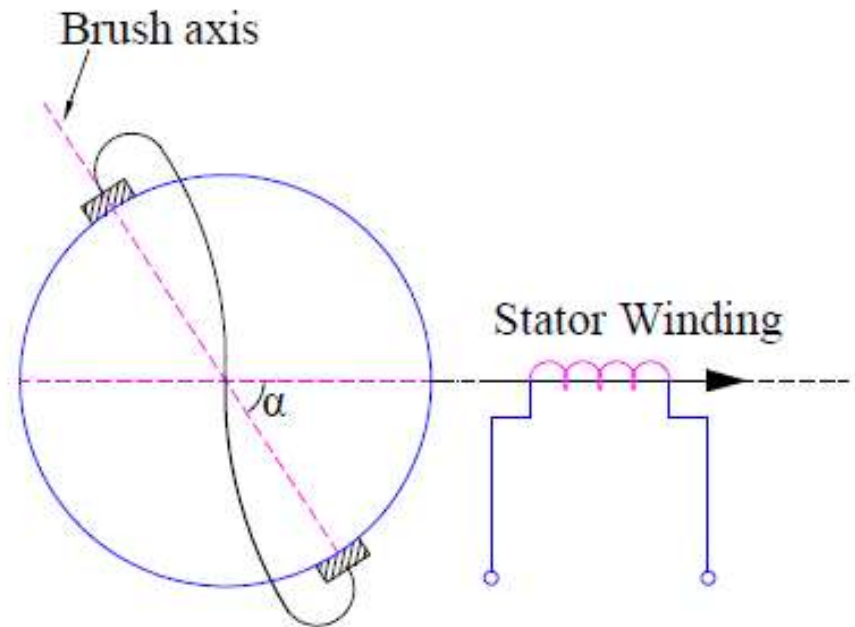

SINGLE PHASE INDUCTION MOTOR

REPULSION MOTOR

Construction of Repulsion Motor

The main components of repulsion motor are stator, rotor and commutator brush assembly. The stator carries a single phase exciting winding similar to the main winding of single phase induction motor. The rotor has distributed DC winding connected to the commutator at one end just like in DC motor. The carbon brushes are short circuited on themselves.

The stator winding have single phase AC winding which produces the working mmf in the air gap. The brushes on rotor are shown to be shorted. As the rotor circuit is shorted, the rotor receives power from stator by transformer action.

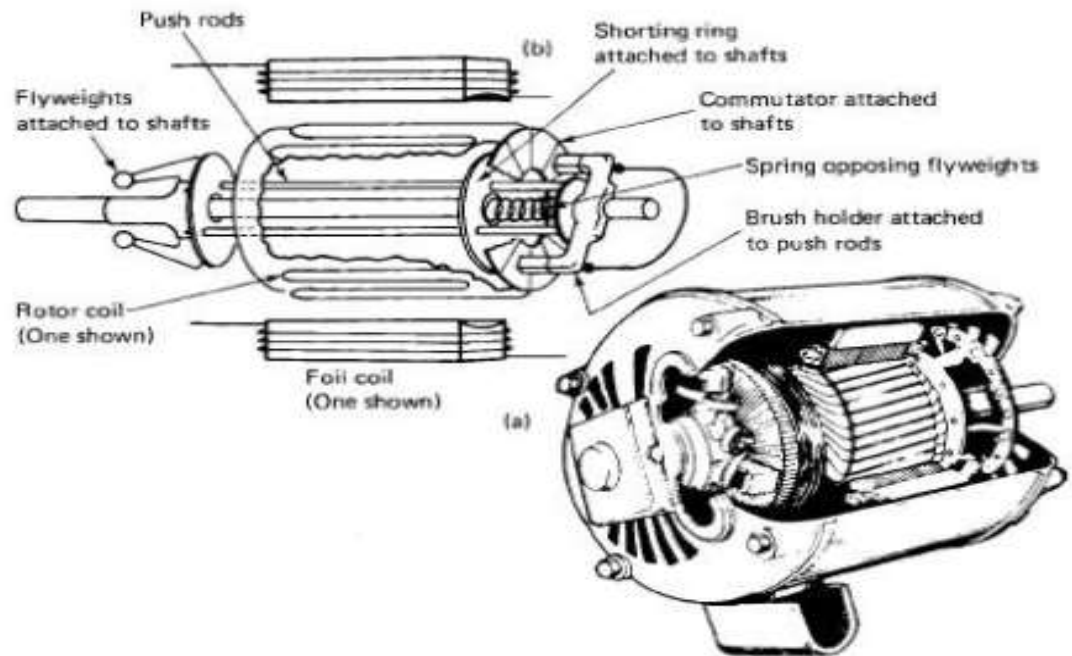

SINGLE PHASE INDUCTION MOTOR

Working principle of Repulsion Motor

The basic principle behind the working of repulsion motor is that “similar poles repel each other.” This means two North poles will repel each other. Similarly, two South poles will repel each other.

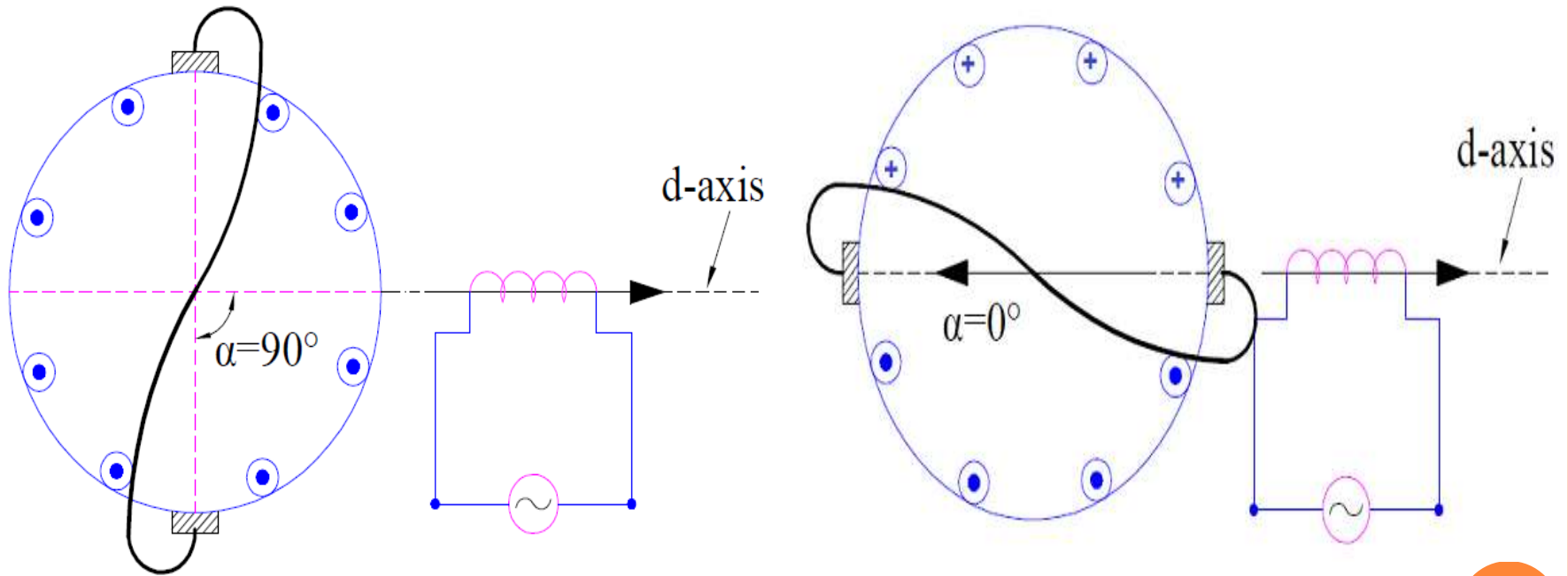

SINGLE PHASE INDUCTION MOTOR

Working principle of Repulsion Motor

When the stator winding of repulsion motor is supplied with single phase AC, it produces a magnetic flux along the direct axis as shown in figure above by arrow mark. This magnetic flux when link with the rotor winding, creates an emf. Due to this emf, a rotor current is produced. This rotor current in turn produces a magnetic flux which is directed along the brush axis due to commutator assembly. Due to the interaction of stator and rotor produced fluxes, an electromagnetic torque is produced.

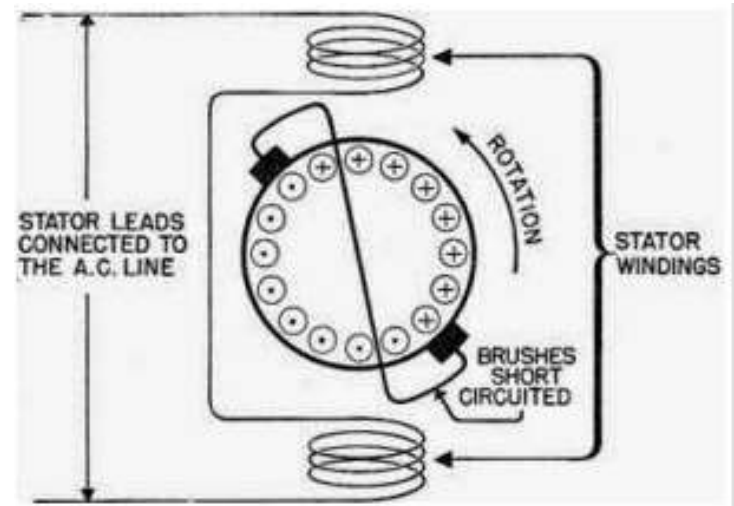
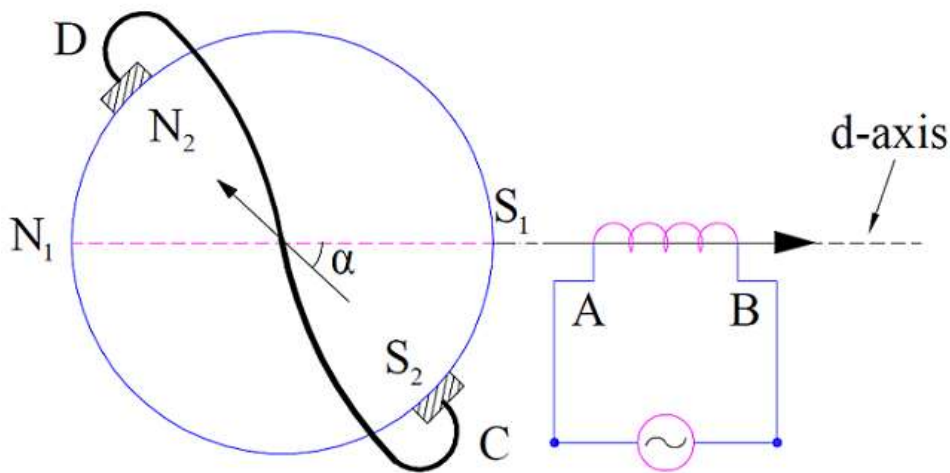

SINGLE PHASE INDUCTION MOTOR

REPULSION MOTOR

APPLICATION

- 1.It is used to drive compressors.
- 2.Petrol pumps
- 3.Air pump
- 4.Mixing machines
- 5.Machine tools
- 6.Hoists



SINGLE PHASE INDUCTION MOTOR

REPULSION MOTOR

ADVANTAGES

- 1.starting torque high
- 2.speed regulation good
- 3.it can develop torque sudden heavy loads
- 4.starting current reduced



TOPIC:

- ❑ LOSSES IN A SINGLE PHASE I.M**
- ❑ POWER FLOW IN A SINGLE PHASE I.M**
- ❑ PROBLEM SOLVING**

**Lecture:
10**

SINGLE PHASE INDUCTION MOTOR

VARIOUS LOSSES IN AN INDUCTION MOTOR

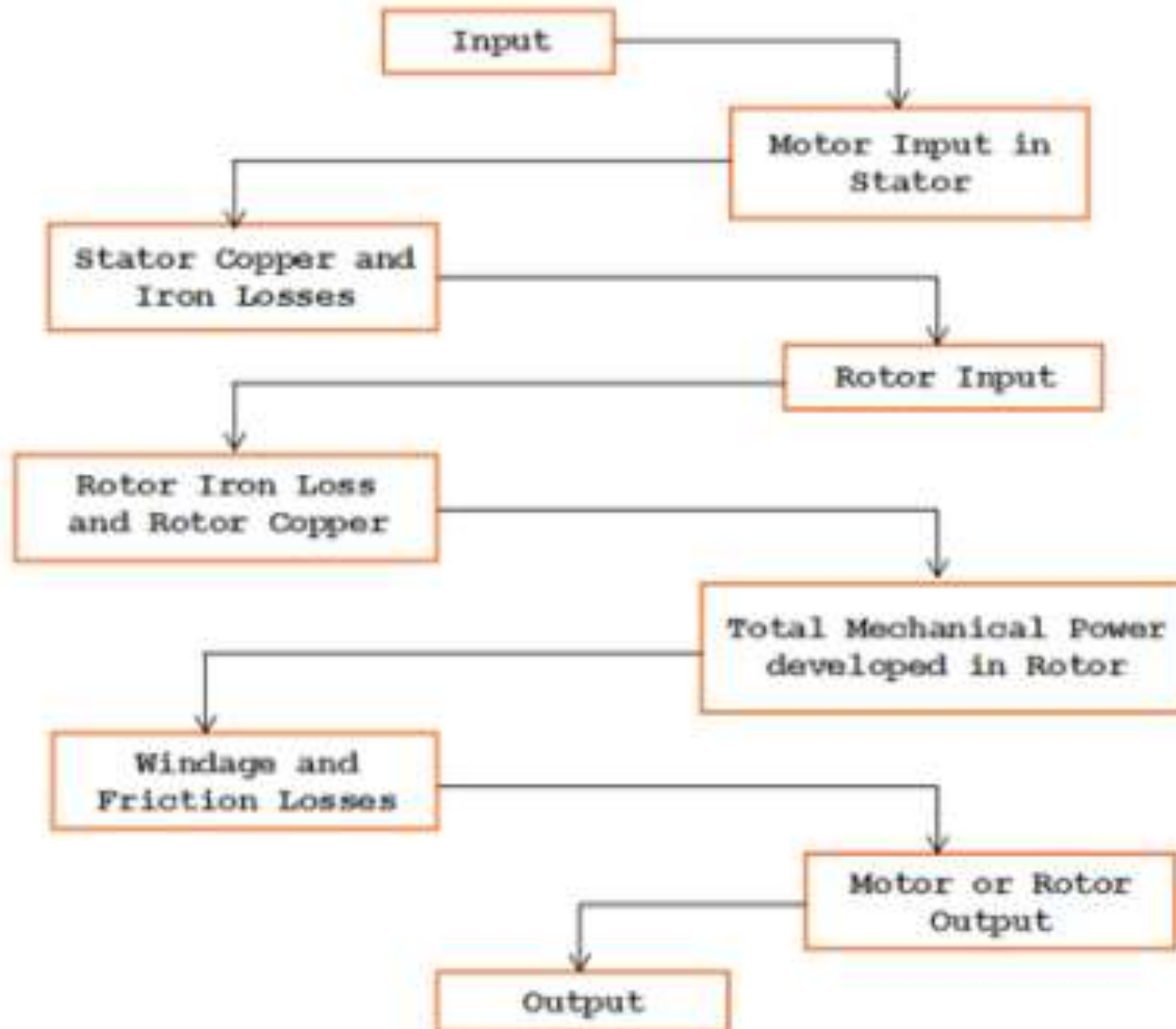

SINGLE PHASE INDUCTION MOTOR

POWER FLOW IN SINGLE-PHASE INDUCTION MOTOR

The performance of a single phase induction motor can be analyzed from its equivalent circuit and in the same way as was done for a three-phase induction motor; except that there are effects of both forward and backward components of power and torque in a single phase induction motor. The same general power and torque expressions that were used for three-phase induction motor can be used for a single-phase motor also for forward and backward rotating fields. The net power and torque in a single phase machine is the difference between the forward and backward components. The power flow diagram of a single phase induction motor is exactly similar to a three phase motor.

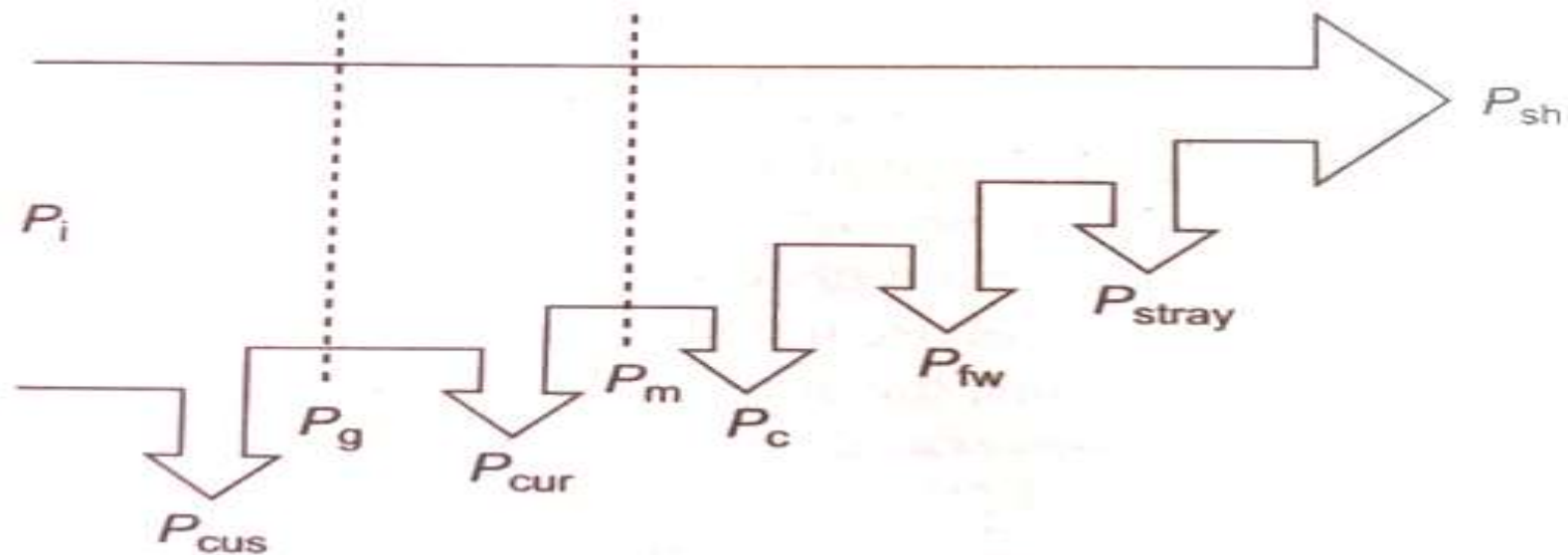

SINGLE PHASE INDUCTION MOTOR

PROBLEM-01

A 230 V, four-pole, 50 Hz single-phase induction motor has the following impedances at standstill:

Main Winding: $r = 1.2$ ohm, $x = 3.0$ ohm

Auxiliary winding $r = 3.0$ ohm, $x = 4$ ohm

Calculate the resistance to be added to the auxiliary winding in order to give maximum torque at starting.

SOLUTION:

$$r'_a = x_a \times \frac{(Z_m + r_m)}{x_m} = 4 \times \frac{(3.23 + 1.2)}{3} = 5.91 \Omega$$

Given that,

Main Winding: $r = 1.2$ ohm, $x = 3.0$ ohm

Auxiliary winding $r = 3.0$ ohm, $x = 4$ ohm

Therefore, additional resistance to be added

$$Z_m = \sqrt{r_m^2 + x_m^2} = \sqrt{1.2^2 + 3^2} = 3.23 \Omega$$

$$r'_a - r_a = 5.91 - 3 = 2.91 \Omega$$

Value of auxiliary winding resistance required to achieve maximum Starting torque is



SINGLE PHASE INDUCTION MOTOR

PROBLEM-02

For a 200 V, single phase, 50 Hz, 1440 rpm induction motor, following are the test data:

Blocked rotor test: 48 V, 12 A, 520 W

No load Test: 220 V, 10.4 A, 380 W

Determine the equivalent circuit parameters.

SOLUTION:

Blocked rotor test:

$$R_{sc} = r_1 + \frac{r_2}{2} \times 2 = r_1 + r_2 = \frac{P_{sc}}{(I_{sc})^2} = \frac{520}{(12)^2} = 3.61 \Omega$$

$$Z_{sc} = \frac{V_{sc}}{I_{sc}} = \frac{48}{12} = 4 \Omega$$

$$X_{sc} = x_1 + \frac{x_2}{2} \times 2 = x_1 + x_2 = \sqrt{Z_{sc}^2 - R_{sc}^2}$$
$$= \sqrt{4^2 - 3.61^2} = 1.723 \Omega$$

$$r_2 = r_1 = \frac{R_{sc}}{2} = \frac{3.61}{2} = 1.805 \Omega$$

$$x_2 = x_1 = \frac{X_{sc}}{2} = \frac{1.723}{2} = 0.8615 \Omega$$

$$\text{No-load impedance } Z_0 = \frac{V_0}{I_0} = \frac{220}{10.4} = 21.154 \Omega$$

$$\text{No-load power factor } \cos \theta_0 = \frac{P_0}{V_0 I_0} = \frac{380}{220 \times 10.4} = 0.166$$

$$\therefore \sin \theta_0 = \sqrt{1 - \cos^2 \theta_0} = \sqrt{1 - 0.166^2} = 0.986$$

The no-load equivalent reactance:

$$X_0 = Z_0 \sin \theta_0 = 21.154 \times 0.986 = 20.86 \Omega$$

$$\text{Since, } X_0 = x_1 + \frac{x_m}{2} + \frac{x_2}{2}$$

\therefore Value of the magnetizing reactance x_m in the equivalent circuit:

$$x_m = 2 \times \left(X_0 - x_1 - \frac{x_2}{2} \right) = 2 \times \left(20.86 - 0.8615 - \frac{0.8615}{2} \right)$$
$$= 39.14 \Omega$$

TOPIC:

**❑ TESTING OF SINGLE PHASE
INDUCTION MOTOR**

**❑ APPLICATION OF SINGLE PHASE
INDUCTION MOTOR**

**❑ ADVANTAGES OF SINGLE PHASE
INDUCTION MOTOR**

**Lecture:
09**

SINGLE PHASE INDUCTION MOTOR

Testing of Single Phase Induction Motor

Demand of energy is growing day by day and along with it cost of energy rising abruptly, so now it is necessary that the health of large motors which consumes maximum power should be taken care off. Tests are required to check the condition of the induction motor and to get the basic idea of malfunctioning of the motor. Now a day lots of techniques and tests are available which gives the complete health card of the induction motors. By monitoring some parameters like voltage, current, temperature, and vibration problem could be diagnosed and by correcting these faults the overall efficiency of the machine can be improved. This will reduce the energy consumption and operational costs.

There are several types of single phase motors. What is however common to them all is that they have a Start Winding, a Run Winding, and a Common connection between them as shown below:

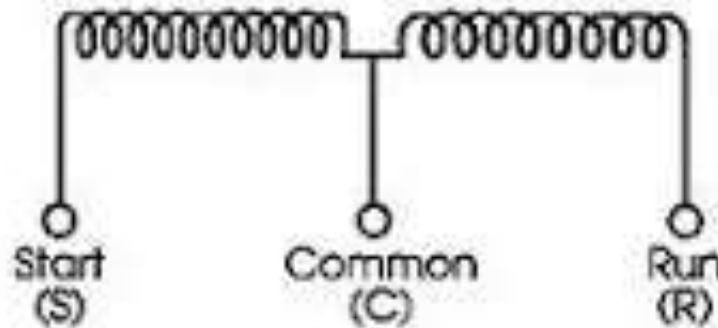

SINGLE PHASE INDUCTION MOTOR

Testing of Single Phase Induction Motor

Basic Parameters to be Checked

1. Current

As line current in all the phases are not equal so the arithmetic mean of the phase currents should be used for evaluating machine performance.

2. Voltage

voltage is measured at the motor terminals and at the time of test, it should be approximately balanced. Machine performance can be calculated by using average of the phase voltages.

3. Power

power input to three phase motor can be calculated by a single watt meters as they are connected in two watt meter method.

4. Resistance

It is necessary to check the ground resistance between the motor body and terminals of the machine.



SINGLE PHASE INDUCTION MOTOR

Testing of Single Phase Induction Motor

Tests for Induction Motor

Number of test is done on induction motor to check its different parameters. All the tests are divided into two parts:

1. Preliminary Tests

These tests are performed to check the electrical or mechanical defects of the induction motor.

- A. Firstly check the components of motor like
 - i. Broken rotor bars
 - ii. High resistance joints
 - iii. Cracked end rings
- B. No-load running current test
- C. High potential test
- D. Air-gap measurement
- E. Balancing of current
- F. Temperature rise in bearing
- G. Voltages in shaft
- H. Direction of rotation
- I. Level of noise
- J. Strength of vibration
- K. Air gap eccentricity



SINGLE PHASE INDUCTION MOTOR

Testing of Single Phase Induction Motor

2. Performance Tests

The purpose of these tests is to estimate the performance characteristics of the induction motor. Along with preliminary tests, these tests are also done on motor.

- A. No load test
- B. Locked rotor test
- C. Breakdown torque load performance test
- D. Temperature test
- E. Stray load loss test
- F. Determination of efficiency test



SINGLE PHASE INDUCTION MOTOR

Testing of Single Phase Induction Motor

How To Test and Check Single phase Electric Motors

Testing of single phase motors is pretty easy if certain basic steps are followed. The objective of any AC motor test is to determine the health status of the motor. The basic steps in ascertaining the health of any motor are given below

- (a) General Inspections
- (b) Earth Continuity and Resistance Test
- (c) Power Supply Test
- (d) AC Motor Winding Resistance Test
- (e) Insulation Resistance Test
- (f) Running Amps Test



SINGLE PHASE INDUCTION MOTOR

Testing of Single Phase Induction Motor

General Inspections

For the single phase motor, do the following:

- (1) Check the appearance of the motor. Check for burnt, damage to body or cooling fan or shaft.
- (2) Manually rotate motor shaft to examine bearing condition. Look out for smooth and free shaft rotation. If shaft rotation is free and smooth, bearing is possibly in good condition, otherwise consider replacing.
- (3) As with all testing and inspections, the motor name plate provides valuable information that will help to ascertain the true health of the motor. Examine the name plate thoroughly.

Earth Continuity and Resistance Test

With a multimeter, measure the resistance between motor frame (body) and earth. A good motor should read less than 0.5 ohms. Any value greater 0.5 ohms indicate trouble with the motor.

Power Supply Test

For single phase motors, the expected voltage is about 230V or 208V depending whether you are using the UK or America voltage system. Check that the correct voltage is applied to the motor.



SINGLE PHASE INDUCTION MOTOR

Testing of Single Phase Induction Motor

AC Motor Winding Resistance Test

Check the motor winding resistance or ohms reading with a multimeter. Since there are three terminals – S, C, R – in a single phase motor, measure winding resistance:

C to S, C to R and S to R. Measured Value S to R should be = C to S + C to R

As a rule to single phase motors, the following applies:

- (1) Ohms reading between S and R should give the maximum reading of resistance
- (2) Ohms reading between C and R should give the lowest reading of resistance
- (3) Ohms reading between C and S should give some intermediate value between that for S to R and C to R

Any deviation signifies a possibly bad electric motor or a motor that requires repairs.

Insulation Resistance Test

Insulation resistance failure of an electric motor is one of the first signs that the motor is about to fail. Insulation resistance is usually measured between motor windings and earth using an insulation tester or megometer. Set the voltage setting of the insulation resistance tester to 500V and check motor windings to earth. Check C to E, S to E, R to E. Minimum test value for a good electric motor is at least $1M\Omega$

Running Amps Test

With the motor running, check the full load amps (FLA) with a suitable meter or preferably a clamp on meter and compare with the motor name plate FLA. Deviations from rated FLA could signify problems with the motor under test.



SINGLE PHASE INDUCTION MOTOR

Testing of Single Phase Induction Motor

Induction Motor Testing

All induction motors are tested before shipment from the factory. This testing can be subdivided in two groups:

Routine tests

Complete or prototype tests

IEEE Std 112-1996 applies to induction motor testing.

Routine tests

The primary purpose of the routine test is to insure freedom from electrical and mechanical defects, and to demonstrate by means of key tests the similarity of the motor to a "standard" motor of the same design. The "standard" motor is an imaginary motor whose performance characteristics would agree exactly with the expected performance predictions.

Depending on the size of the motor, some or all of the following tests could constitute routine tests:

- Winding resistance measurement
- No-load running current and power
- High-potential test
- Locked-rotor test
- Air-gap measurement
- Direction of rotation and phase sequence
- Current balance
- Insulation resistance measurement
- Bearing temperature rise
- Magnetic center at no-load
- Shaft voltages
- Noise
- Vibration



SINGLE PHASE INDUCTION MOTOR

Testing of Single Phase Induction Motor

Induction Motor Testing

Prototype tests

The purpose of a prototype test is to evaluate all the performance characteristics of the motor. This test consists of the following tests in addition to the routine tests:

- ✓ No-load saturation characteristic
- ✓ Locked rotor saturation characteristic
- ✓ Locked rotor torque and current
- ✓ Loss measurement including stray load loss
- ✓ Determination or measurement of efficiency
- ✓ Temperature rise determination
- ✓ Surge withstand test



SINGLE PHASE INDUCTION MOTOR

Applications of single phase induction motor

Single phase induction motors are used in smaller equipment where we require less horsepower (for example, one horsepower). Some of the examples of real life are

- 1. Pumps**
- 2. Compressors**
- 3. Small fans**
- 4. Mixers**
- 5. Toys**
- 6. High-speed vacuum cleaners**
- 7. Electric shavers**
- 8. Drilling machines**



SINGLE PHASE INDUCTION MOTOR

Induction Motor Maintenance

The maintenance program for every five/six months:

1. Clean motor thoroughly, blowing out dirt from windings, and wipe commutator and brushes.
2. Check brushes and replace any that are more than half worn
3. Examine brush holders, and clean them if dirty. Make sure that brushes ride free in the holders.
4. Drain, wash out and replace oil in sleeve bearings.
5. Check grease in a ball or roller bearings.
6. See that all covers, and belt and gear guards are in place, in good order, and securely fastened.
7. Inspect and tighten connections on motor and control.



SINGLE PHASE INDUCTION MOTOR

Induction Motor Maintenance

The maintenance program for every year :

1. Clean out and renew grease in ball or roller bearing housings.
2. Clean out magnetic dirt that may be clinging to poles.
3. Check clearance between shaft and journal boxes of the sleeve bearing motors to prevent operation with worn bearings.
4. Clean out undercut slots in the commutator. Check the commutator for smoothness.
5. Examine connections between commutator and armature coils.
6. Test insulation by megohmmeter.
7. Check air gap.



SINGLE PHASE INDUCTION MOTOR

ADVANTAGES OF INDUCTION MOTOR

The motor construction and the way electric power is supplied all give the induction motor several advantages:

1. **Low cost:** Induction machines are very cheap when compared to synchronous and DC motors. This is due to the modest design of induction motor.

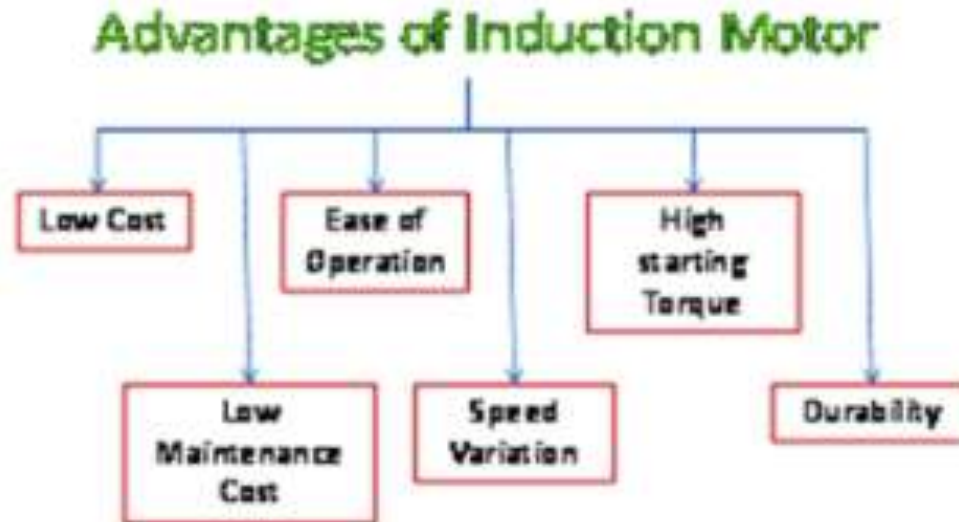

2. **Low maintenance cost:** Induction motors are maintenance free motors unlike dc motors and synchronous motors. The construction of induction motor is very simple and hence maintenance is also easy, resulting in low maintenance cost.



SINGLE PHASE INDUCTION MOTOR

ADVANTAGES OF INDUCTION MOTOR

3. Ease of operation: Operation of induction motor is very simple because there is no electrical connector to the rotor that supply power and current is induced by the movement of the transformer performs on the rotor due to the low resistance of the rotating coils.

4. Speed Variation: The speed variation of induction motor is nearly constant. The speed typically varies only by a few percent going from no load to rated load.

5. Durability: Another major advantage an induction motor is that it is durability. This makes it the ideal machine for many uses. This results the motor to run for many years with no cost and maintenance.

All these advantages make induction motor to use in many applications such as industrial, domestic and in many applications.



TOPIC:

**□ DOUBLE REVOLVING
FIELD THEORY**

□ CROSS-FIELD THEORY

**Lecture:
08**

SINGLE PHASE INDUCTION MOTOR

Double Revolving Field Theory

When a single-phase AC supply is given to the single-phase stator winding, a sinusoidal pulsating magnetic field varying with time is produced. As the produced magnetic field varies two times in a cycle, therefore, no torque will be produced in the rotor and hence the rotor doesn't rotate. Therefore, single-phase induction motors are not self-starting motor.

However, when an initial rotation is given to the rotor, it starts rotating in that direction which can be explained by the double-revolving field theory.

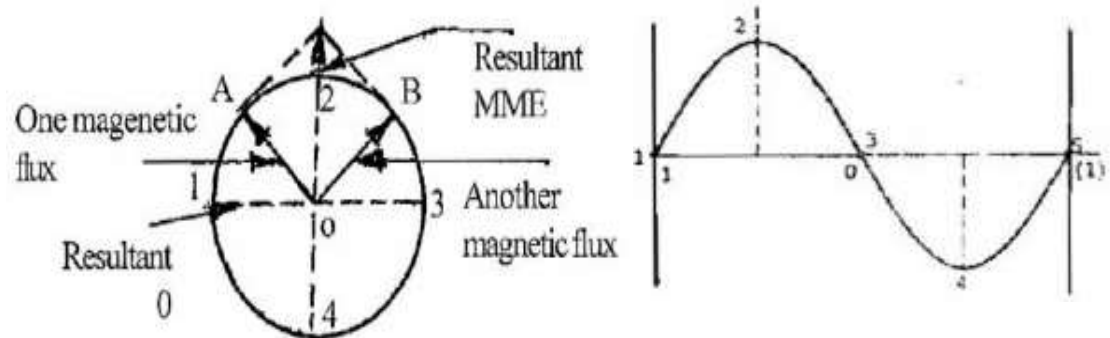

The magnetic field produced by the stator winding when an alternating supply is given is equal to the sum of the two revolving fields rotating at synchronous speed in the opposite direction of equal magnitude. The magnitude of each revolving field is equal to one half of the maximum value of the alternating field, i.e., $\phi_{1m} / 2$ where ϕ_{1m} is the maximum value of an alternating field.



SINGLE PHASE INDUCTION MOTOR

Double Revolving Field Theory

Let us consider the two revolving fields as ϕ_f (rotating in an anti-clockwise direction) and ϕ_b (rotating in a clockwise direction). The resultant ϕ_R of these two fields gives the value of the magnetic field produced by the alternating supply (i.e., alternating field).

Consider the different instances as shown below :

(i). The two fields ϕ_f and ϕ_b are shown opposite to each other at start, and resultant magnetic field $\phi_R = 0$

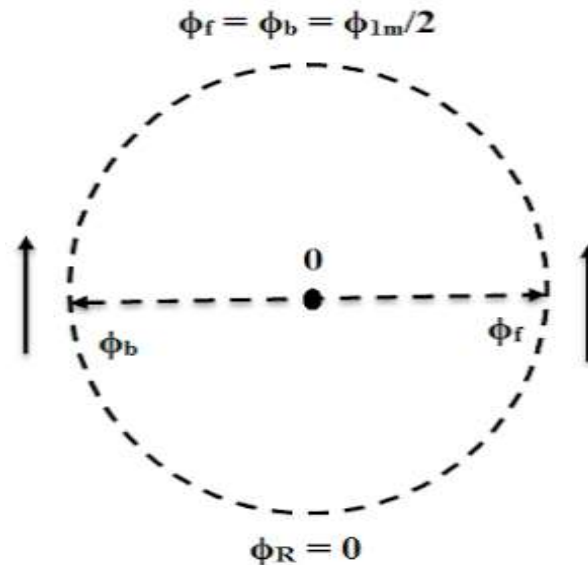

SINGLE PHASE INDUCTION MOTOR

Double Revolving Field Theory

(ii). After 90° , the two fields are rotated in such a way that both of them are now pointing in the same direction.

The resultant magnetic field,

This instant gives maximum the magnitude of the original alternating field.

So the continuous rotation of these two fields (components) gives the original stator magnetic field. This is purely alternating in nature.

Now each separate component is rotated and hence gets cut by the rotor conductors. Due to cutting of flux emf get induced in rotor conductors which circulate in the rotor current. The rotor current produces rotor flux.

The rotor flux interacts with one component ϕ_f produces a torque in an anti-clockwise direction and the rotor flux interacts with the second component ϕ_b produces a torque in a clockwise direction.

$$\begin{aligned}\phi_R &= \phi_f + \phi_b \\ &= \frac{\phi_{1m}}{2} + \frac{\phi_{1m}}{2} = \phi_{1m}\end{aligned}$$

$$\phi_R = \phi_{1m}$$

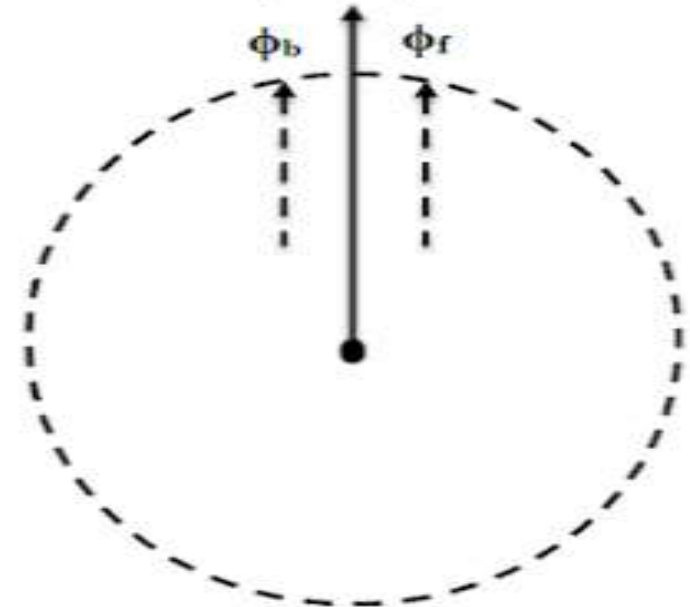

SINGLE PHASE INDUCTION MOTOR

Double Revolving Field Theory

The double-field revolving theory states that, any alternating quantity (here, alternating flux) can be resolved into two components having magnitude half of the maximum magnitude of the alternating quantity, and both these components rotating in opposite direction.

Following figures will help you understanding the double field revolving theory.

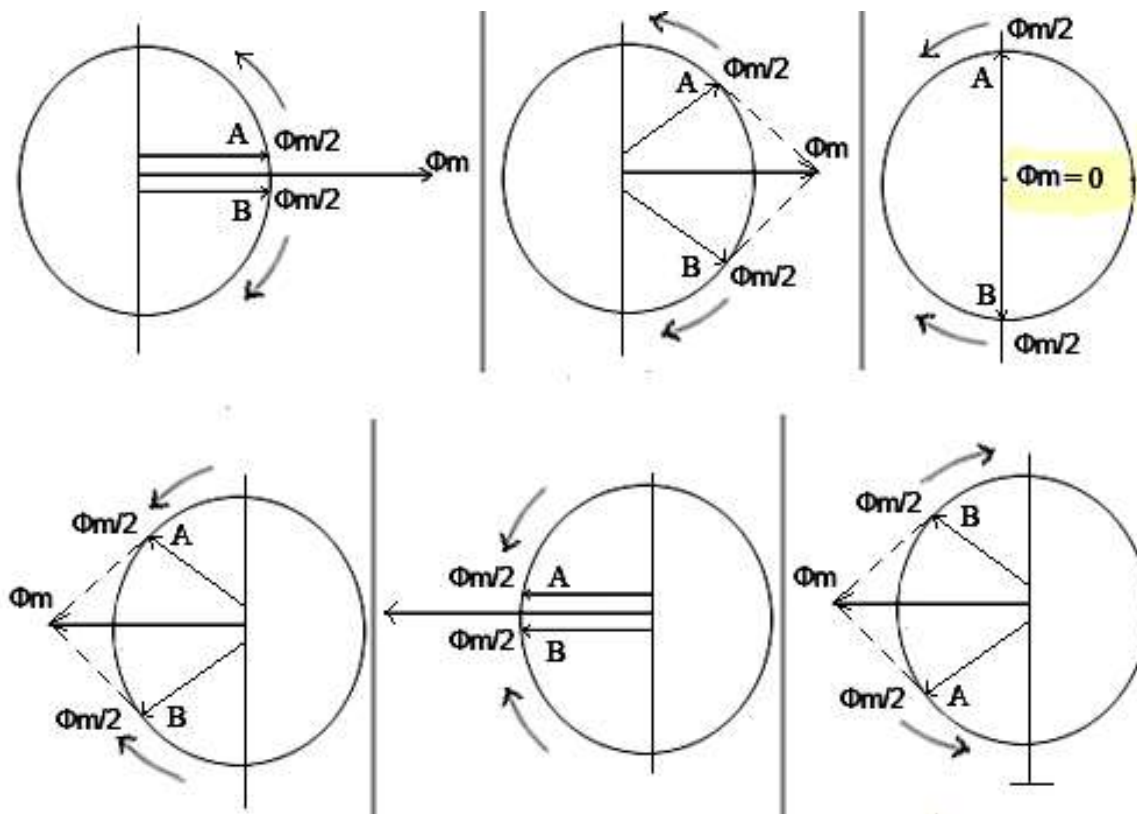

SINGLE PHASE INDUCTION MOTOR

Double Revolving Field Theory

Torque-speed characteristics

1. At +90deg, the forward flux reaches a maximum and the rotor links the stator flux, the rotor induces emf in the forward direction and the motor start rotating at forwarding direction

2. At -90deg, the reverse flux reaches the maximum and the rotor links this flux and induces emf in the reverse direction, hence the motor start rotating in the reverse direction.

Here note that the direction of the rotor flux is always in phase with the stator flux.

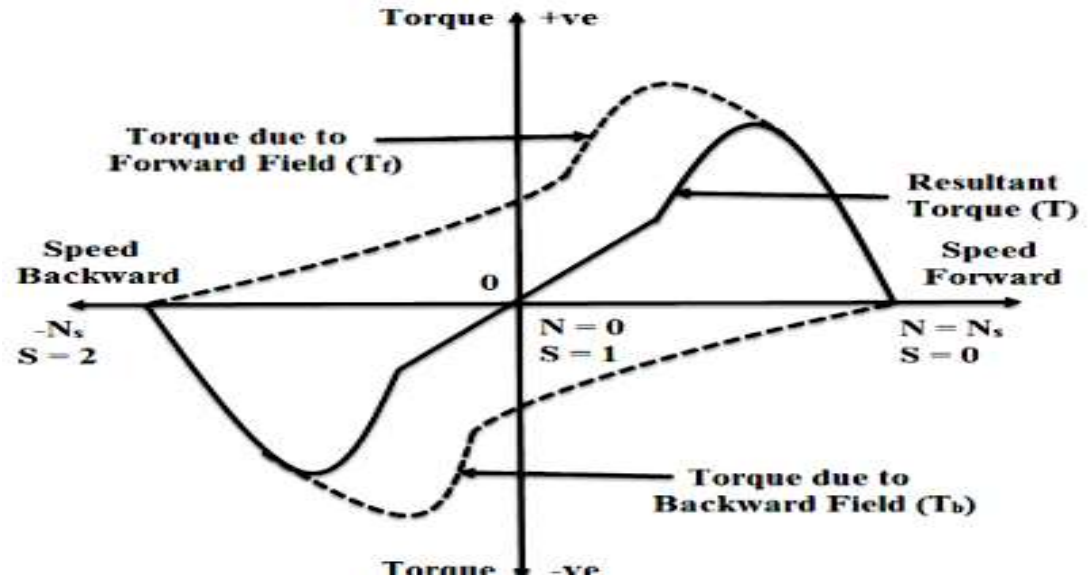

By referring 1 and 2 we get equal and opposite rotation for a single cycle in the motor due to the alternating nature.

The resultant torque is equal to zero and the motor rotor remains stands at the previous position.

That's why the single-phase motor is not self-starting.



SINGLE PHASE INDUCTION MOTOR

Double Revolving Field Theory

Why single phase induction motor is not self starting

The stator of a single phase induction motor is wound with single phase winding. When the stator is fed with a single phase supply, it produces alternating flux (which alternates along one space axis only). Alternating flux acting on a squirrel cage rotor can not produce rotation, only revolving flux can. That is why a single phase induction motor is not self starting.

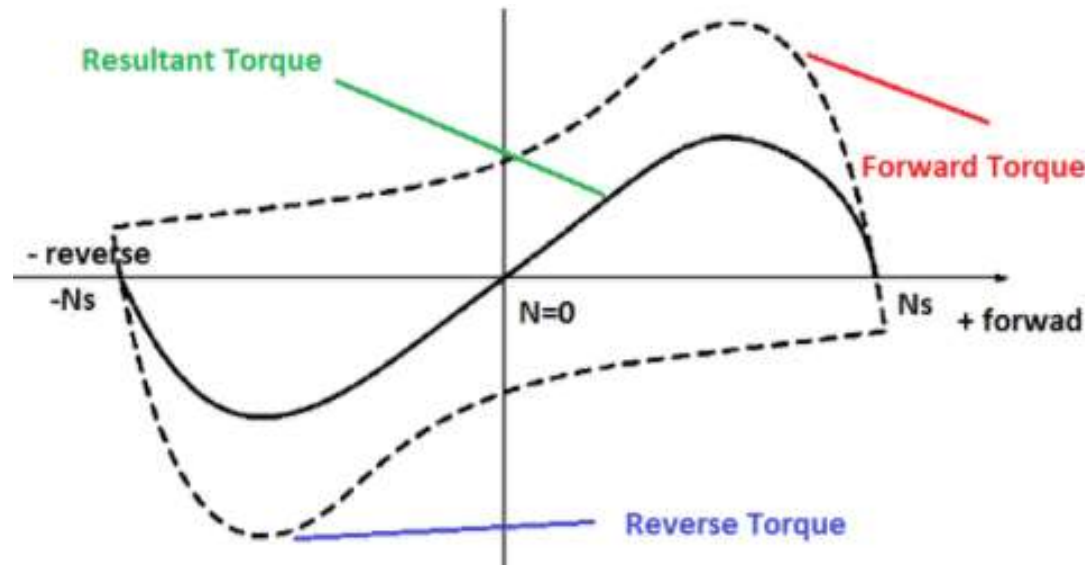

SINGLE PHASE INDUCTION MOTOR

Double Revolving Field Theory

How to make single phase induction motor self starting

As explained above, **single phase induction motor is not self-starting**. To make it self-starting, it can be temporarily converted into a two-phase motor while starting. This can be achieved by introducing an additional 'starting winding' also called as auxiliary winding.

Hence, stator of a single phase motor has two windings: (i) Main winding and (ii) Starting winding (auxiliary winding). These two windings are connected in parallel across a single phase supply and are spaced 90 electrical degrees apart. Phase difference of 90 degree can be achieved by connecting a capacitor in series with the starting winding.

Hence the motor behaves like a two-phase motor and the stator produces revolving magnetic field which causes rotor to run. Once motor gathers speed, say up to 80 or 90% of its normal speed, the starting winding gets disconnected from the circuit by means of a centrifugal switch, and the motor runs only on main winding.



SINGLE PHASE INDUCTION MOTOR

Double Revolving Field Theory

Cross-field Theory

It is interesting to know how a single-phase induction motor can be able to rotate when an initial rotation or starting torque is given to it. This can be understood with the help of cross-field theory.

1. Motor at Standstill

Consider standstill conditions with the stator winding connected to a single-phase AC supply. The stator current establishes a field acting along the horizontal axis as shown in the below figure. The stator field is alternating in polarity and varying sinusoidal with time. The alternating field will induce an emf in the rotor winding by transformer action. This emf will cause a current to flow in the rotor winding.

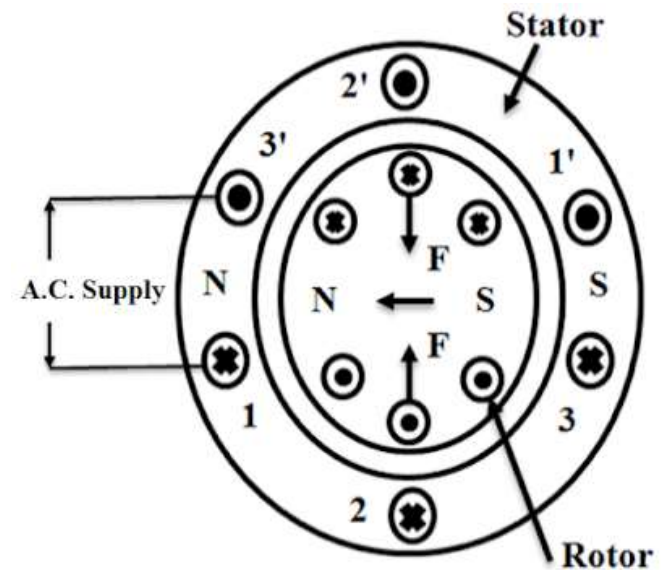

SINGLE PHASE INDUCTION MOTOR

Double Revolving Field Theory

Cross-field Theory

The directions of currents in the rotor conductors are also shown. The rotor currents establish poles on the rotor surface and these are in direct line (along the horizontal axis) with the stator poles. The axis of the stator and rotor fields are aligned. The forces on the rotor conductors in top the half are in a downward direction, whereas the forces on the rotor conductors in the bottom half are in the upward direction. The two sets of forces will cancel and the rotor will experience no torque.

2. Motor at Running

When, however, the rotor is made to rotate say in the clockwise direction by some external means, the rotor conductors cut across the stator field, causing an emf to be generated in them. The direction of the EMFs as determined by Fleming's right-hand rule, will be outward in one side of the vertical axis and inward on the other side of the vertical axis as indicated by the dots and crosses as shown in below figure. The generated rotor EMFs vary in phase with the stator current and flux. The rotor current due to these EMFs lags by nearly 90° owing to low 'R' and high 'X' of the rotor winding.



SINGLE PHASE INDUCTION MOTOR

Double Revolving Field Theory

Cross-field Theory

The field produced by the rotor currents is at right angles to the field by the stator currents hence it is known as cross field. Thus the stator field ϕ_s and rotor field ϕ_r are in space and time Quadrature. These two fields will produce a resultant revolving field which will rotate in the direction in which the rotor was given an initial rotation. Hence torque is exerted on the rotor and the motor continues to rotate.

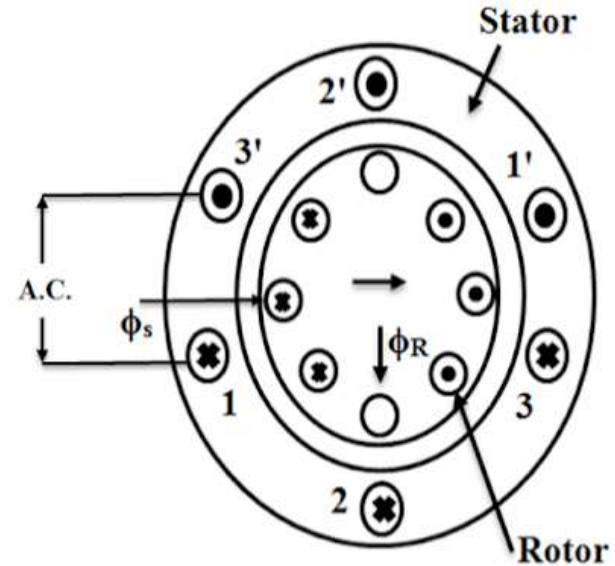

From the above discussion, it may be concluded that :

- (i) At stand still there can be no cross field only the pulsating stator field and therefore the inherent starting torque of a single-phase induced motor is zero.
- (ii) If, however, the rotor is made to run by some external means, then it will continue to develop torque in the direction of rotation.

TOPIC:

□ AC Series Motor

**Lecture:
07**



SINGLE PHASE INDUCTION MOTOR

AC Series Motor

AC series motors are also known as the modified DC series motor as their construction is very similar to that of the DC series motor. Before we discuss these modifications, here it is essential to discuss what is the need and where do we need to do modifications. In order to understand this, consider this question. What will happen when we give an AC supply to DC series motor? Answer to this question is written below:

1. An AC supply will produce an unidirectional torque because the direction of both the currents (i.e. armature current and field current) reverses at the same time.
2. Due to presence of alternating current, eddy currents are induced in the yoke and field cores which results in excessive heating of the yoke and field cores.
3. Due to the high inductance of the field and the armature circuit, the power factor would become very low.
4. There is sparking at the brushes of the DC series motor.



SINGLE PHASE INDUCTION MOTOR

AC Series Motor

So considering above points we can say that we don't have good performance of DC series motor on the application of AC supply. Now in order to reduce the eddy currents there is need to laminate the yoke and field core. This is our first modification to DC series motor.

What about power factor how we can improve power factor? Now the power factor is directly related to reactance of the field and armature circuit and we can reduce the field winding reactance by reducing the number of turns in the field winding.

But there is one problem: on reducing the number of turns, field mmf will decrease and due to this the air gap flux decrease. The overall result of this is that there is an increase in the speed of the motor but decrease in the motor torque which is not desired. Now how to overcome this problem? The solution to this problem is the use of compensating winding. On the basis of the usage of compensating winding we have two types of motor and they are written below:

1. Conductively compensated type of motors.
2. Inductively compensated type of motors.



SINGLE PHASE INDUCTION MOTOR

AC Series Motor

Principle of Operation of A.C. Series Motor

An ordinary d.c. Series motor will run in the same direction regardless of the polarity of the supply. The direction of the torque depends upon the relative directions in space of flux and armature current. If the line terminals are reversed, both the field and armature current are reversed, the direction of torque remains unchanged. Therefore, the motor continues to rotate in the same direction.

So when normal d.c. series motor is connected to an A.C. supply, both field and armature currents reverse simultaneously and unidirectional torque is produced in the motor.

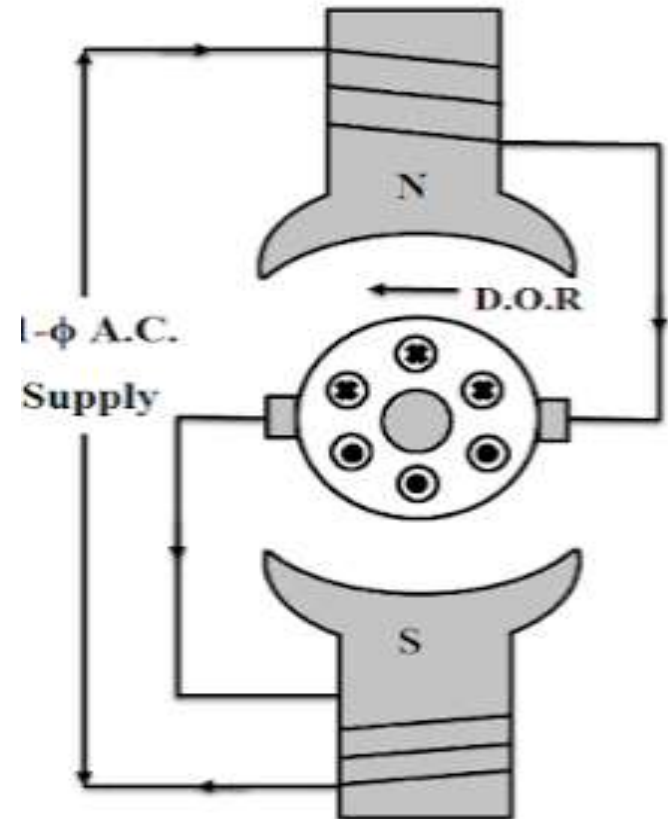

SINGLE PHASE INDUCTION MOTOR

AC Series Motor

Principle of Operation of A.C. Series Motor

Consider the case of a two-pole motor and let the alternating current be in its positive half, then the polarity of the field poles and the currents flowing through the armature conductors be as indicated in Figure. The armature conductors carry inward currents +ve under N-pole and outward currents -ve under S-pole. By applying Fleming's left hand rule it will be seen that the torque developed in the armature will try to rotate in an anti-clockwise direction.

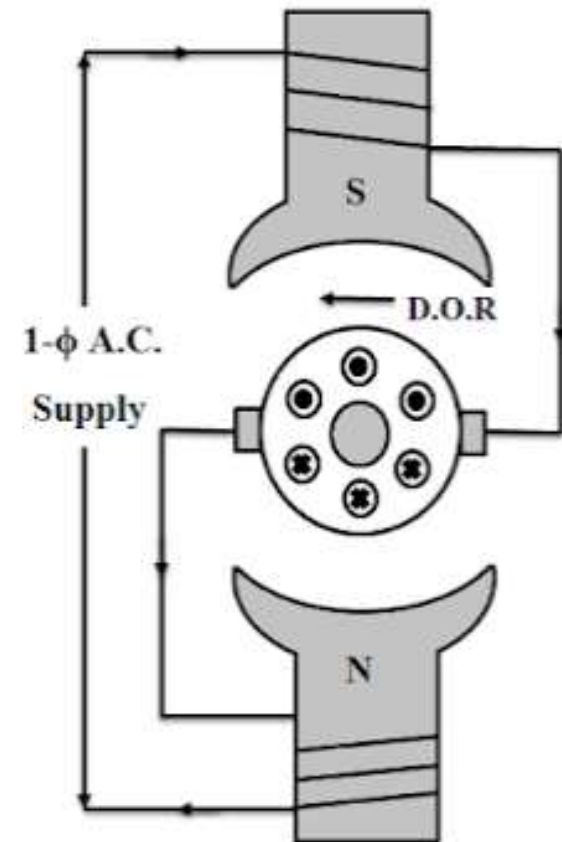

During the next instant, the alternating current goes through the negative half cycle. Now the current through the field winding and armature will also change. It will be again seen that the armature will tend to rotate in the same direction because of uniform torque produced in the two halves of the cycle.



SINGLE PHASE INDUCTION MOTOR

AC Series Motor

Principle of Operation of A.C. Series Motor

Thus a series motor can run on both the d.c. supply and A.C. supply.

The performance of dc Series motor works on A.C. Supply is not satisfactory due to the following reasons

1. The efficiency is low. This is because of the increase in core losses due to alternating flux.
2. The reactance of the field and armature winding increases as the supply given is alternating, which makes the machine to run at low power factor.
3. Considerable sparking at brushes will occur. This is due to poor commutation. The voltage induced by transformer action in the coil undergoing commutation further intensifies commutation difficulties.



SINGLE PHASE INDUCTION MOTOR

AC Series Motor

Constructional Features

Modification in Design of A.C. Series Motor :

Some modifications are required to have a satisfactory performance of d.c. series motor on A.C supply, when it is called as A.C. series motor. The modifications are :

1. Fully laminated poles and yokes must be used in order to reduce eddy current losses.
2. The power factor can be improved by reducing field and armature reactance's. In order to reduce field reactance, the field winding is designed with less number of turns. Lower pole flux also reduces the transformer emf in the commutating coil.
3. The motor should be provided with a large number of poles each supplying less flux per pole.
4. Reduction in the number of turns on the field winding would also reduce field flux. To keep the torque constant on the shaft, the armature turns should be increased proportionately. This increases the armature reaction and armature reactance.

SINGLE PHASE INDUCTION MOTOR

AC Series Motor

Constructional Features

Modification in Design of A.C. Series Motor :

5. Compensating winding should be employed to lower the armature reactance as far as possible. Compensation also improves commutation.

The flux produced by compensating winding is opposite to that produced by the armature and effectively neutralizes the armature reaction.

6. The armature coils are single turn coils and brushes of less width are used not to short circuit more than two coils at a time.

7. The air gap is made very small so that fewer field turns can be used per pole.

8. The frequency of supply used is reduced. The transformer emf is proportional to frequency and hence good commutation is easy at lower frequencies.



SINGLE PHASE INDUCTION MOTOR

AC Series Motor

Performance Characteristics

The speed-torque characteristic for dc operation would lie somewhat higher as shown dotted. This is because of reactance voltage drops $[I_a(x_f + X_a)]$ in ac operation so that E_a and hence speed is lower for a given current and torque. The power factor of an ac operated AC Series Motor is rather poor because of the large series reactance $(x_f + X_a)$.

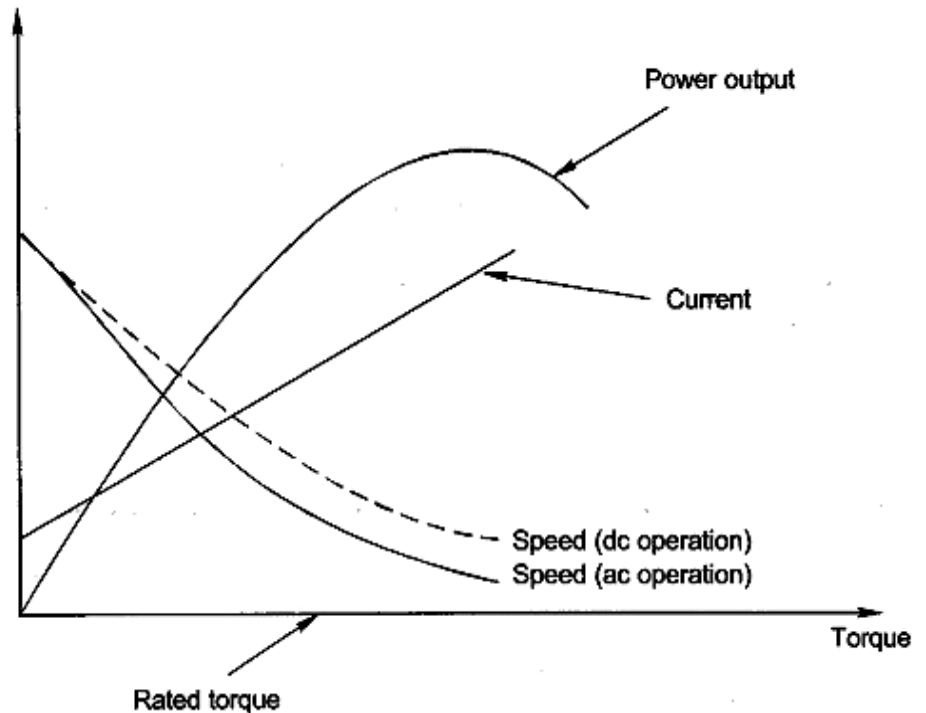

The characteristics of a.c. series motor is similar to that of d.c. series motor. The torque is proportional to the square of the armature current and speed is inversely proportional to the armature current. The series motors must always be started with some load on it because at the starting speed of the motor is very high due to high starting torque i.e., 3 to 4 times the full load torque.



SINGLE PHASE INDUCTION MOTOR

AC Series Motor

Phasor Diagram of A.C. Series Motor

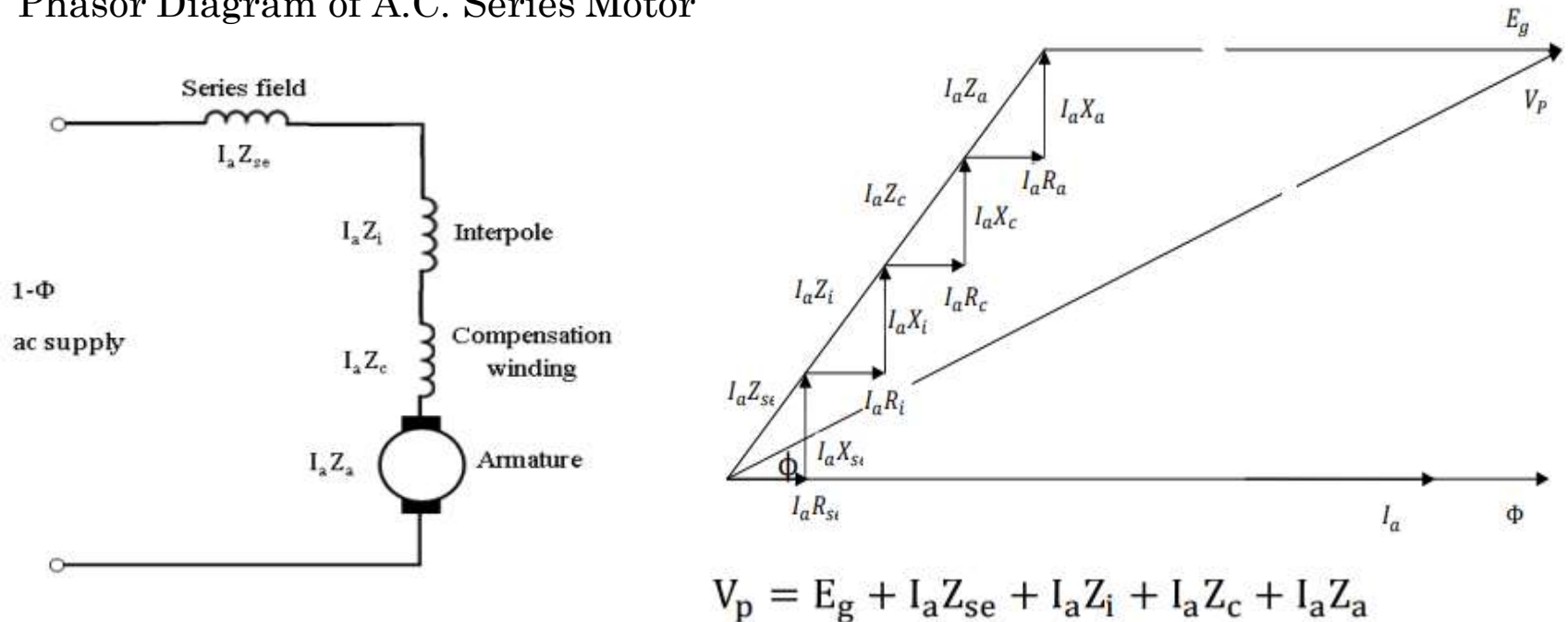

The resistance drops due to resistances of series field, inter-pole winding, compensating winding and of armature respectively are in phase with armature current. The reactance drops due to reactance of series field, inter-pole winding compensating winding and of armature respectively lead current by 90° . The generated armature counter emf is the terminal phase voltage is equal to the phasor sum of E_g and all the impedance drops in series.



SINGLE PHASE INDUCTION MOTOR

AC Series Motor

Conductively Compensated Type of Motors

Given below is the circuit diagram of the conductively compensated type of motors. In this type of motor, the compensating winding is connected in series with the armature circuit. The winding is put in the stator slots. The axis of the compensating winding is 90° (electrical) with main field axis.

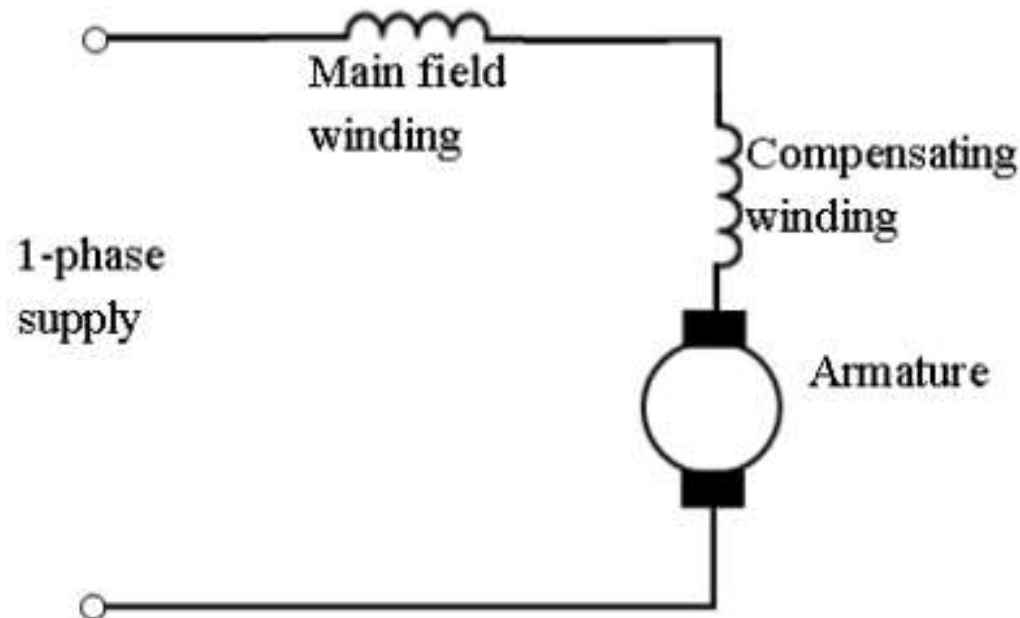

SINGLE PHASE INDUCTION MOTOR

AC Series Motor

Inductively Compensated Type of Motors

Given below is the circuit diagram of the inductively compensated type of motors. In this type of motor, the compensating winding has no interconnection with the armature circuit of the motor. In this case, a transformer action will take place as the armature winding will act as primary winding of the transformer and the compensation winding will act as a secondary winding. The current in the compensating winding will be in phase opposition to the current in the armature winding.

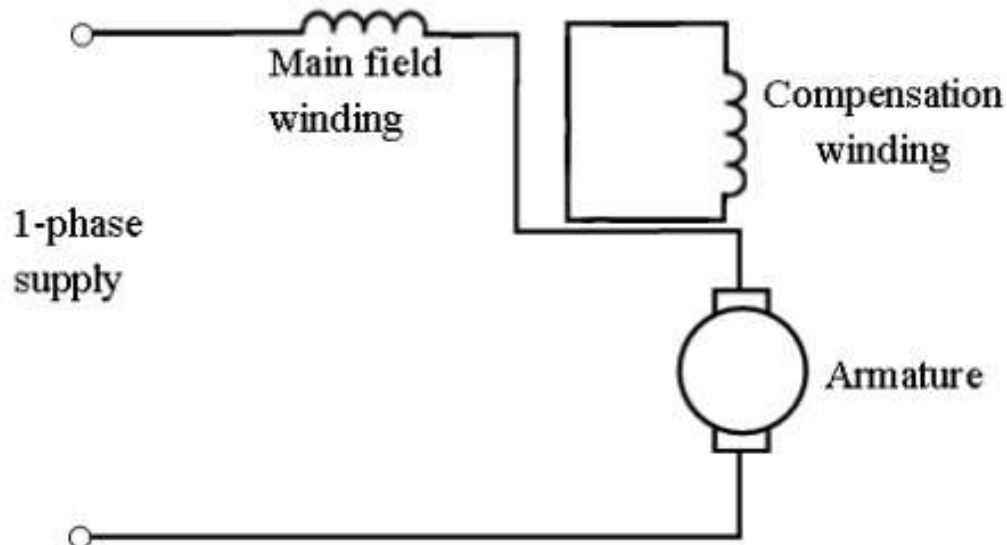

SINGLE PHASE INDUCTION MOTOR

AC Series Motor

Given below is the complete schematic diagram of the single phase **AC series motor** with all the modifications (i.e. compensating winding and inter pole).

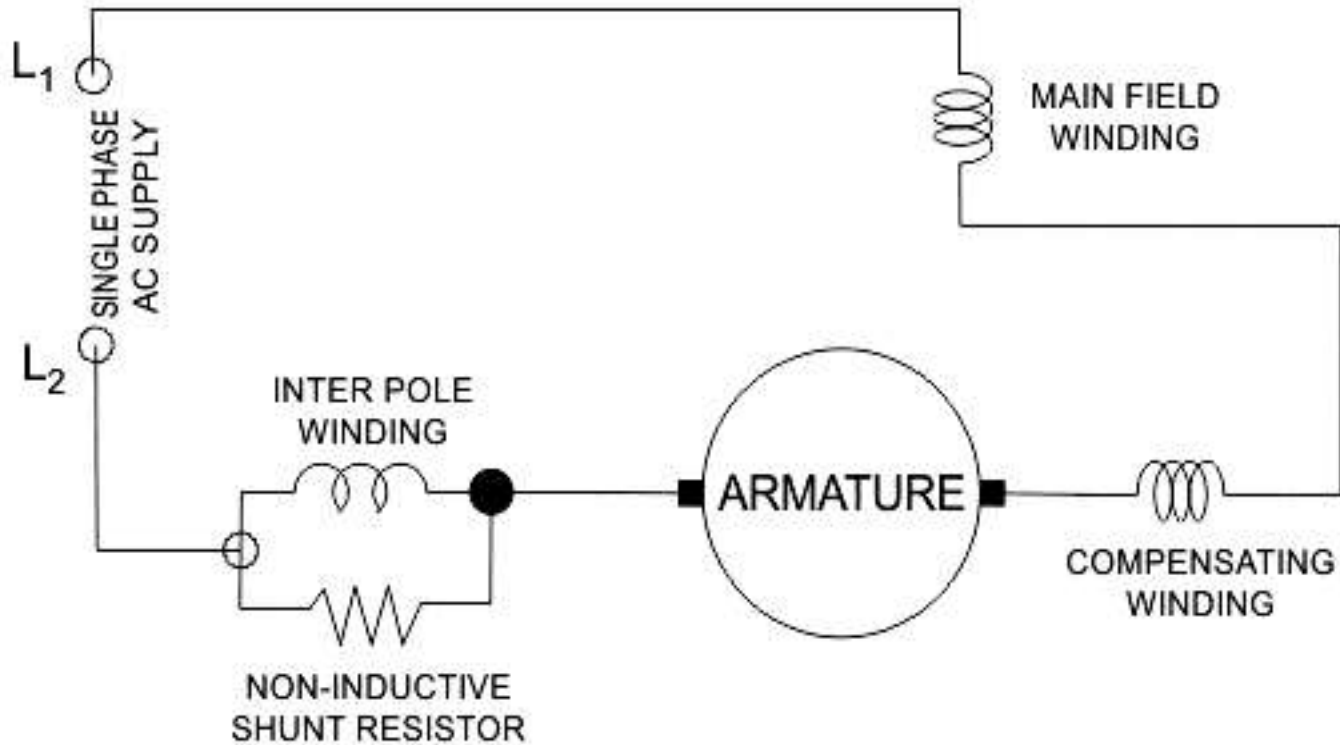

SINGLE PHASE INDUCTION MOTOR

AC Series Motor

Applications

The Universal motor is used for the purposes where speed control and high values of the speed are necessary.

There are numerous applications where universal motors are used, such as

1. Portable drills
2. Hair dryers
3. Grinders
4. Table-fans
5. Blowers
6. Polishers
7. Kitchen appliances etc.

Universal motors of a given horse power rating are significantly smaller than other kinds of a.c. motors operating at the same frequency.



TOPIC:

**□ LOAD TEST OF SINGLE PHASE
INDUCTION MOTOR**

**Lecture:
06**



SINGLE PHASE INDUCTION MOTOR

LOAD TEST OF SINGLE PHASE INDUCTION MOTOR

The load test on induction motor helps us to compute the complete performance of induction motor means to calculate the various quantities i.e. torque, slip, efficiency, power factor etc at different loading. In this test supply voltage is applied to motor and variable mechanical load is applied to the shaft of motor. Mechanical load can be provided by brake and pulley arrangement. The input current, input voltage, input power and speed of motor are observed from the experiment and various performance quantities



SINGLE PHASE INDUCTION MOTOR

LOAD TEST OF SINGLE PHASE INDUCTION MOTOR

1. SLIP

Due to the three-phase supply given to stator of an induction motor, a rotating magnetic field of constant magnitude is set up in the stator of the motor. The speed with which this rotating magnetic field rotates is known as synchronous speed and is given by

$$N_s = \frac{120f}{P}$$

Where

f = supply frequency.

P = no of poles on the stator of the rotor.

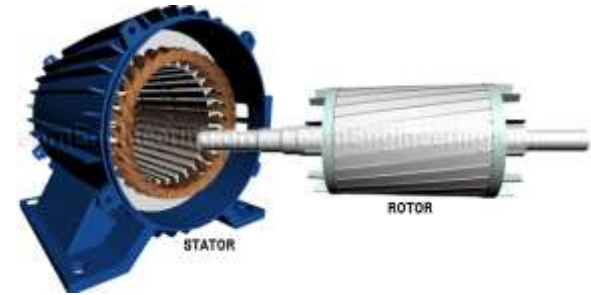

The actual speed of the rotor N_r is always less than the synchronous speed. So the slip of the motor is given by

$$s = \frac{N_s - N_r}{N_s} \times 100\%$$

This value of slip at full load lies between 2 to 5%



SINGLE PHASE INDUCTION MOTOR

LOAD TEST OF SINGLE PHASE INDUCTION MOTOR

2. TORQUE

Mechanical loading is applied on induction motor by means of brake and pulley arrangement. The belt can be tightened or loosened by means of threaded rods with handles fixed on frame. Two spring balances are provided at the end of belt. The net force exerted at the brake drum can be obtained from the readings of the two spring balance i.e. F1 and F2

Net force exerted on drum, $F = (F_1 - F_2) \text{ Kgf}$

And Torque $T = F \times \frac{d}{2} \times 9.81 \text{ Nw-m}$

Where d = effective diameter of brake drum in meter.

3. OUTPUT POWER

The output power of induction motor can be calculated as $P_o = \frac{2\pi N_r T}{60}$

Where N_r = speed of induction motor in rpm.



SINGLE PHASE INDUCTION MOTOR

LOAD TEST OF SINGLE PHASE INDUCTION MOTOR

4. INPUT POWER

The input power can be calculated from the readings of wattmeter connected in the circuit

$$P_{in} = W$$

5. POWER FACTOR

The power factor can be calculated from the following relation

$$\cos \Phi = \frac{P_{in}}{VI}$$

6. EFFICIENCY

The efficiency of induction motor can be calculated using the relation

$$\eta = \frac{\text{output power}}{\text{input power}} \times 100\%$$



SINGLE PHASE INDUCTION MOTOR

LOAD TEST OF SINGLE PHASE INDUCTION MOTOR

Experimental Setup Connection

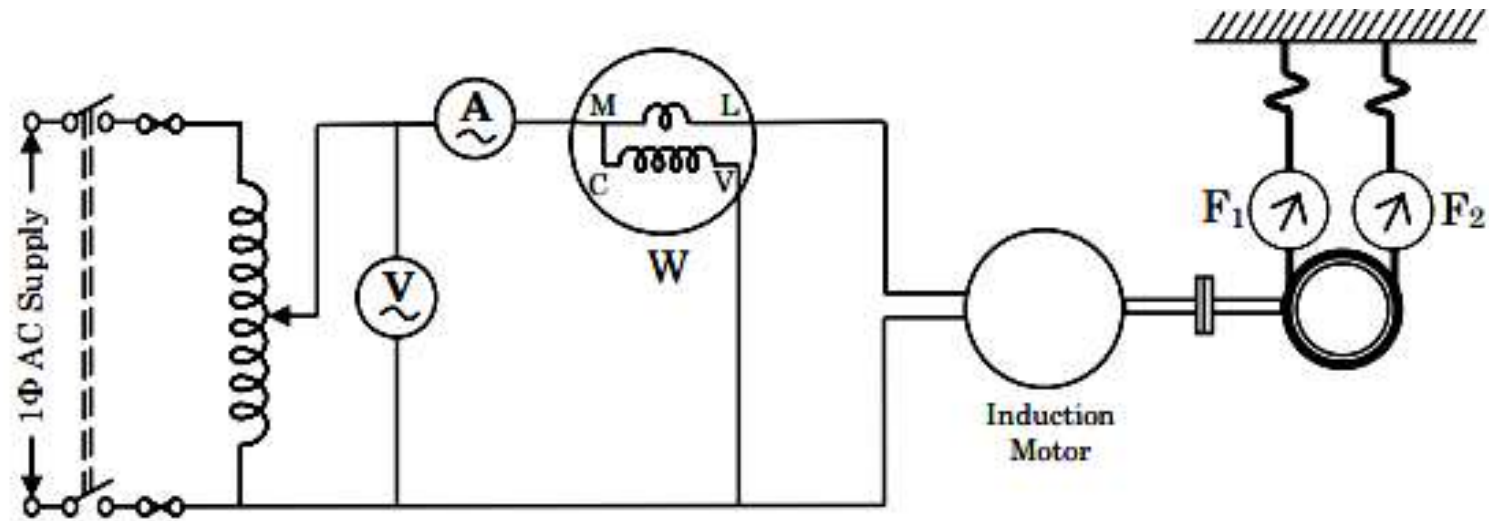

- 1) Set the single-phase Variac at minimum voltage and brake pulley arrangement at no load.
- 2) Switch ON the power supply and start the induction motor.
- 3) Now gradually increase the applied voltage by varying the Variac very slowly up to the rated voltage.
- 4) Increase the mechanical load on motor step by step and note down the various reading for load.
- 5) Switch OFF the supply and disconnect the motor.
- 6) Calculate the various quantities and draw the various curves



SINGLE PHASE INDUCTION MOTOR

LOAD TEST OF SINGLE PHASE INDUCTION MOTOR

OBSERVATION TABLE

SL NO	Input Voltage V (volt)	Input Current I (amp)	Input Power W (watt)	Force (Kgf)			Speed N_r (rpm)
				F_1	F_2	$F = F_1 - F_2$	
1							
2							
3							
4							
5							

CALCULATION

SL NO	Input Power P_{in} (watt)	Total Force F (Kgf)	Output Torque T (Nw-m)	Output Power P_o (watt)	Slip (%)	Power Factor	Efficiency (%)
1							
2							
3							
4							
5							



SINGLE PHASE INDUCTION MOTOR

LOAD TEST OF SINGLE PHASE INDUCTION MOTOR

RESULT

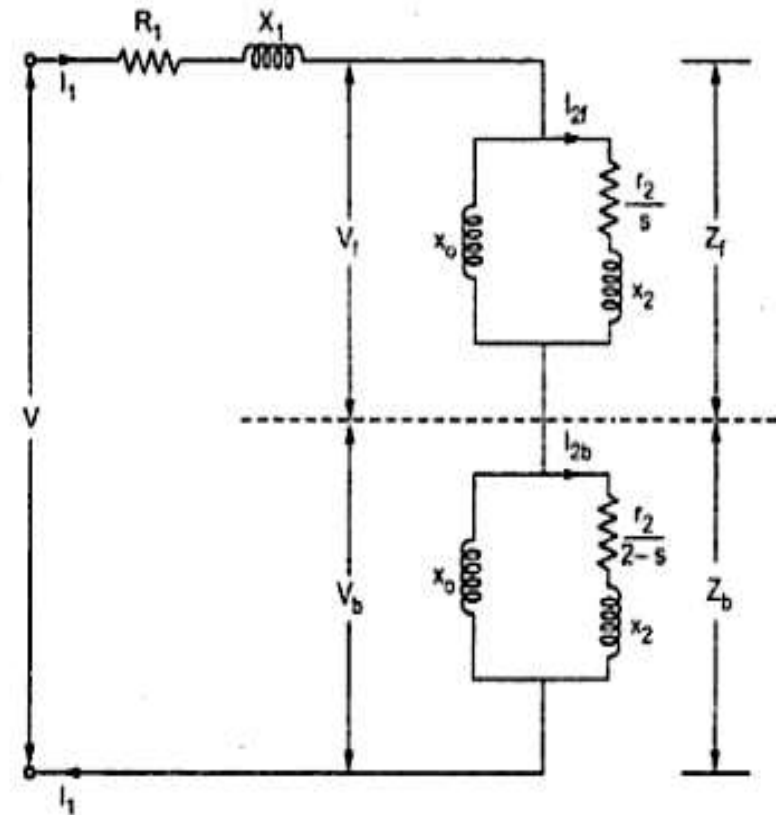
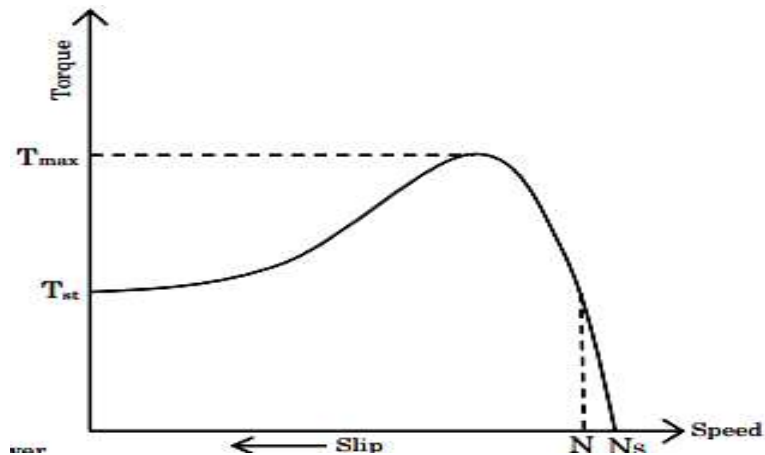
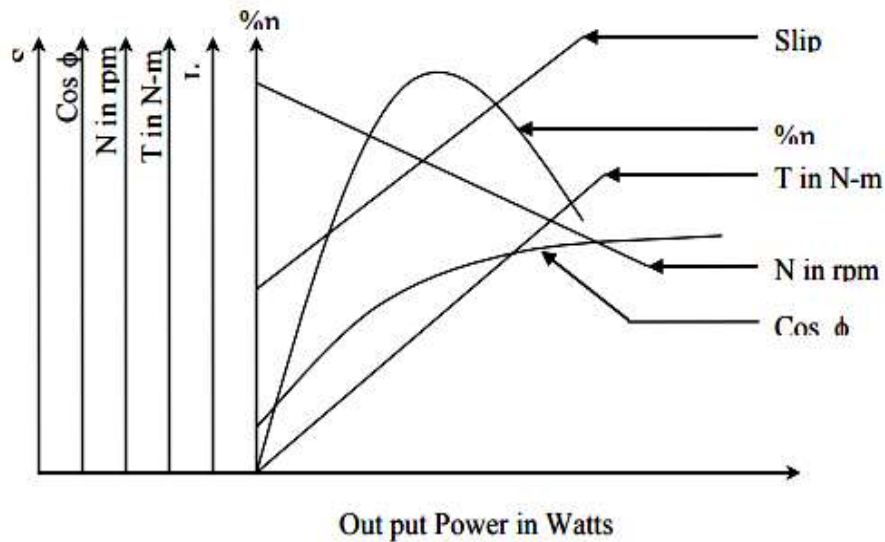

TOPIC:

**□ DETERMINATION OF SINGLE-
PHASE INDUCTION MOTOR
EQUIVALENT CIRCUIT PARAMETERS
BY TEST**

**Lecture:
05**

SINGLE PHASE INDUCTION MOTOR

NO-LOAD AND BLOCKED ROTOR TEST ON AN INDUCTION MACHINE

Similar to a three phase induction motor, the various tests can be performed on single phase induction motor. The results of these tests can be used to obtain the equivalent circuit parameters of a single phase induction motor.

The tests usually conducted are :

1. No load test or open circuit test
2. Blocked rotor test or short circuit test



Single Phase Induction Motor SPECIFICATIONS

Single Phase squirrel cage induction motor

POWER : 1 HP(0.75 KW)

CURRENT : 1.8Amp

SUPPLY: 230V AC 50 Hz input.

Speed : 1450 rpm

Speed sensor with speed indicator



SINGLE PHASE INDUCTION MOTOR

NO-LOAD AND BLOCKED ROTOR TEST ON AN INDUCTION MACHINE

The efficiency of large motors can be determined by directly loading them and by measuring their input and output powers. For larger motors it may be difficult to arrange loads for them. Moreover power loss will be large with direct loading tests. Thus no load and blocked rotor tests are performed on the motors. As the name suggest no load test is performed when rotor rotates with synchronous speed and there is no load torque. This test is similar to the open circuit test on transformer. Actually, to achieve synchronous speed in an induction motor is impossible. The speed is assumed to be synchronized. The synchronous speed can be achieved by taking slip = 0 which creates infinite impedance in the rotor branch.

This test gives the information regarding no-load losses such as core loss, friction loss and windage loss. Rotor copper loss at no load is very less that its value is negligible. Small current is required to produce adequate torque. This test is also well-known as running light test. This test is used to evaluate the resistance and impedance of the magnetizing path of induction motor.



SINGLE PHASE INDUCTION MOTOR

NO-LOAD AND BLOCKED ROTOR TEST ON AN INDUCTION MACHINE

No Load Test of Induction Motor

The impedance of magnetizing path of induction motor is large enough to obstruct flow of current. Therefore, small current is applied to the machine due to which there is a fall in the stator-impedance value and rated voltage is applied across the magnetizing branch. But the drop in stator-impedance value and power dissipated due to stator resistance are very small in comparison to applied voltage. Therefore, these values are neglected and it is assumed that total power drawn is converted into core loss. The air gap in magnetizing branch in an induction motor slowly increases the exciting current and the no load stator I^2R loss can be recognized.

One should keep in mind that current should not exceed its rated value otherwise rotor accelerates beyond its limit.

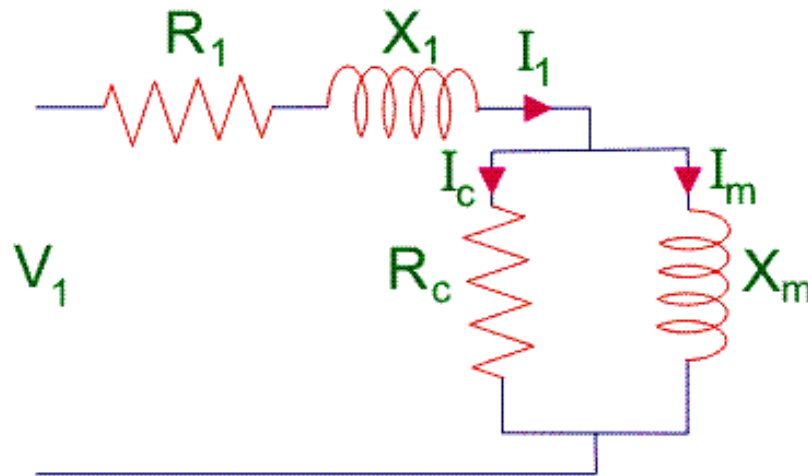

SINGLE PHASE INDUCTION MOTOR

NO-LOAD AND BLOCKED ROTOR TEST ON AN INDUCTION MACHINE

No Load Test of Induction Motor

The test is performed at poly-phase voltages and rated frequency applied to the stator terminals. When motor runs for some times and bearings get lubricated fully, at that time readings of applied voltage, input current and input power are taken. To calculate the rotational loss, subtract the stator I^2R losses from the input power.

The test is conducted by rotating the motor without load. The input current, voltage and power are measured by connecting the ammeter, voltmeter and wattmeter in the circuit. These readings are denoted as :

V_o , I_o and W_o .

Now

$$1. W_o = V_o I_o \cos\Phi$$

The motor speed on no load is almost equal to its synchronous speed hence for practical purposes, the slip can be assumed zero. Hence r_2/s becomes ∞ and acts as open circuit in the equivalent circuit. Hence for forward rotor circuit, the branch $r_2/s + j x_2$ gets eliminated.

While for a backward rotor circuit, the term $r_2/(2 - s)$ tends to $r_2/2$. Thus x_o is much higher than the impedance $r_2/2 + j x_2$. Hence it can be assumed that no current can flow through and that branch can be eliminated.



SINGLE PHASE INDUCTION MOTOR

NO-LOAD AND BLOCKED ROTOR TEST ON AN INDUCTION MACHINE

No Load Test of Induction Motor

Equivalent circuit of induction motor

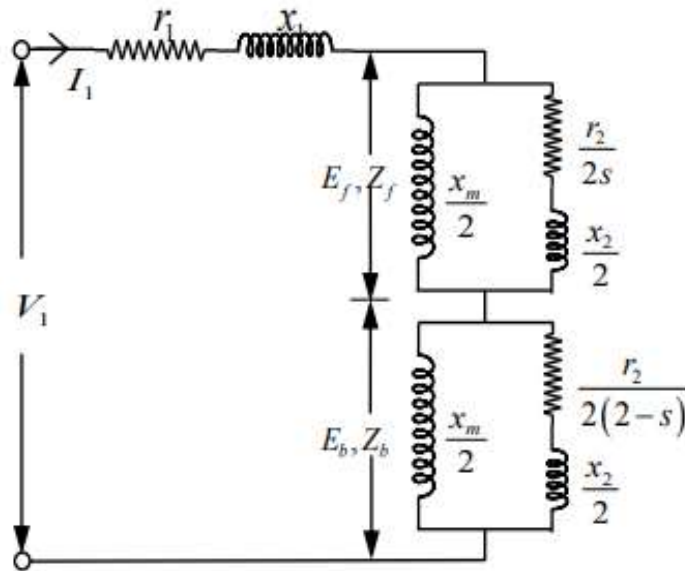

This test is similar to open circuit test on a transformer. A single-phase auto-transformer is used to supply rated voltage at the rated frequency. The motor runs at no load. The power input is measured by wattmeter. With the motor running at no load, the slip is very close to zero. It may be therefore assumed that $s = 0$. Under these conditions $r_2/2s$ becomes infinity and $r_2/2(2-s) = r_2/4$

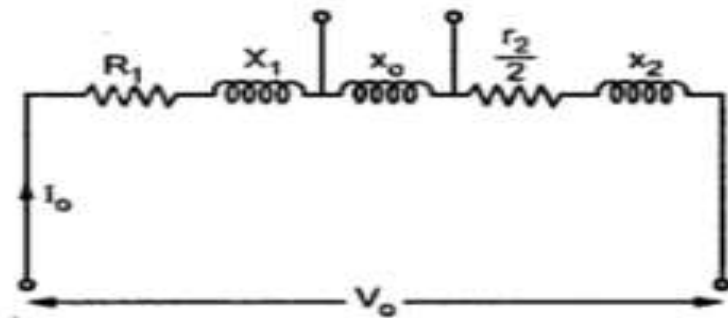
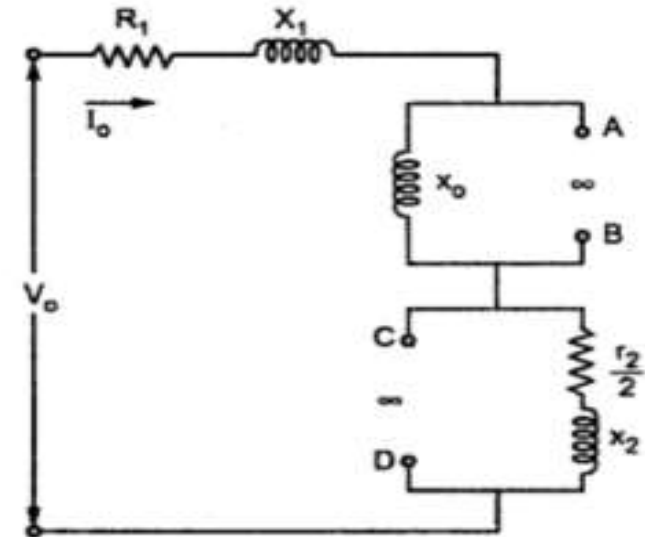

No load test Equivalent circuit of induction motor



SINGLE PHASE INDUCTION MOTOR

NO-LOAD AND BLOCKED ROTOR TEST ON AN INDUCTION MACHINE

No Load Test of Induction Motor

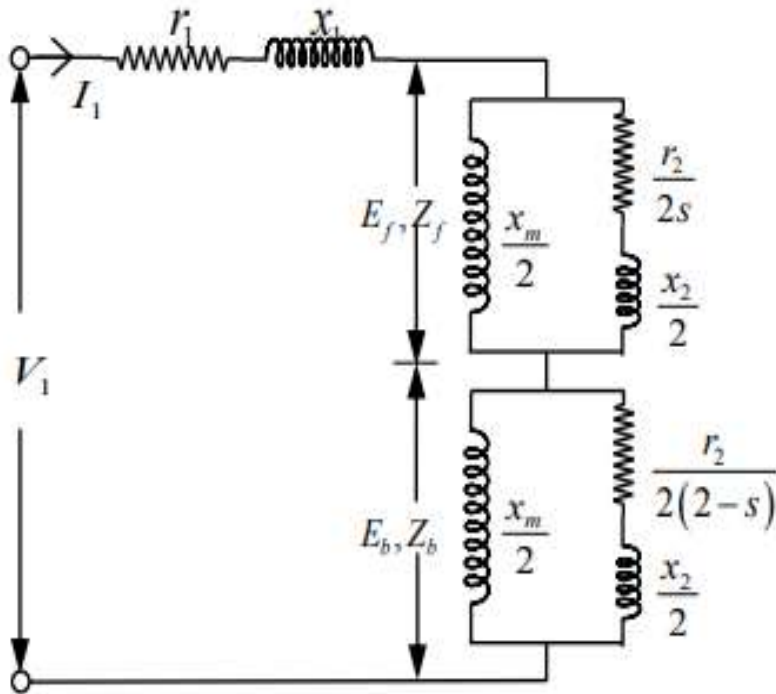

Equivalent circuit of induction motor

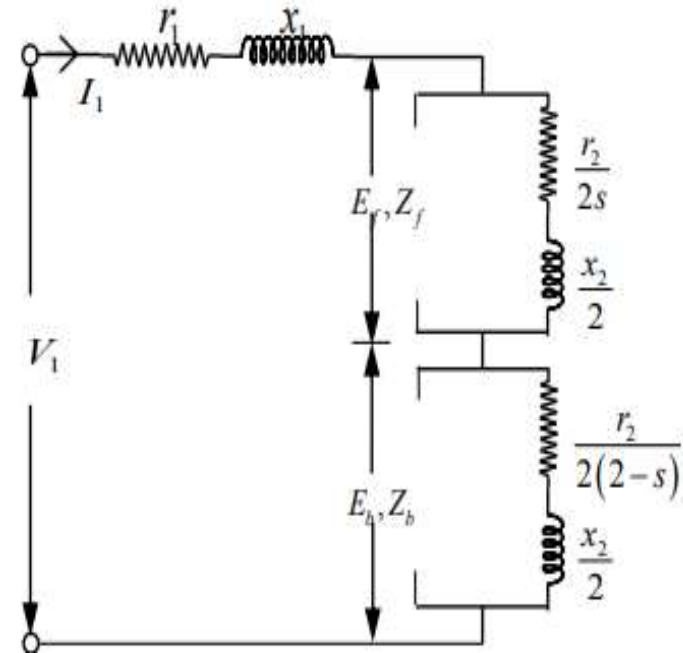

Blocked rotor test Equivalent circuit of induction motor

With the rotor at rest, single-phase voltage, applied to stator main winding, is increased gradually from zero so that rated current flow in main winding. Under these condition i.e. with rotor stationary, the slip $s = 1$ and the voltage required to circulate full-load current is very low. Therefore, flux is small and the magnetizing current flowing to X_m is also very low.



SINGLE PHASE INDUCTION MOTOR

NO-LOAD AND BLOCKED ROTOR TEST ON AN INDUCTION MACHINE

Experimental Set up for NO load and Blocked Rotor Test of I.M

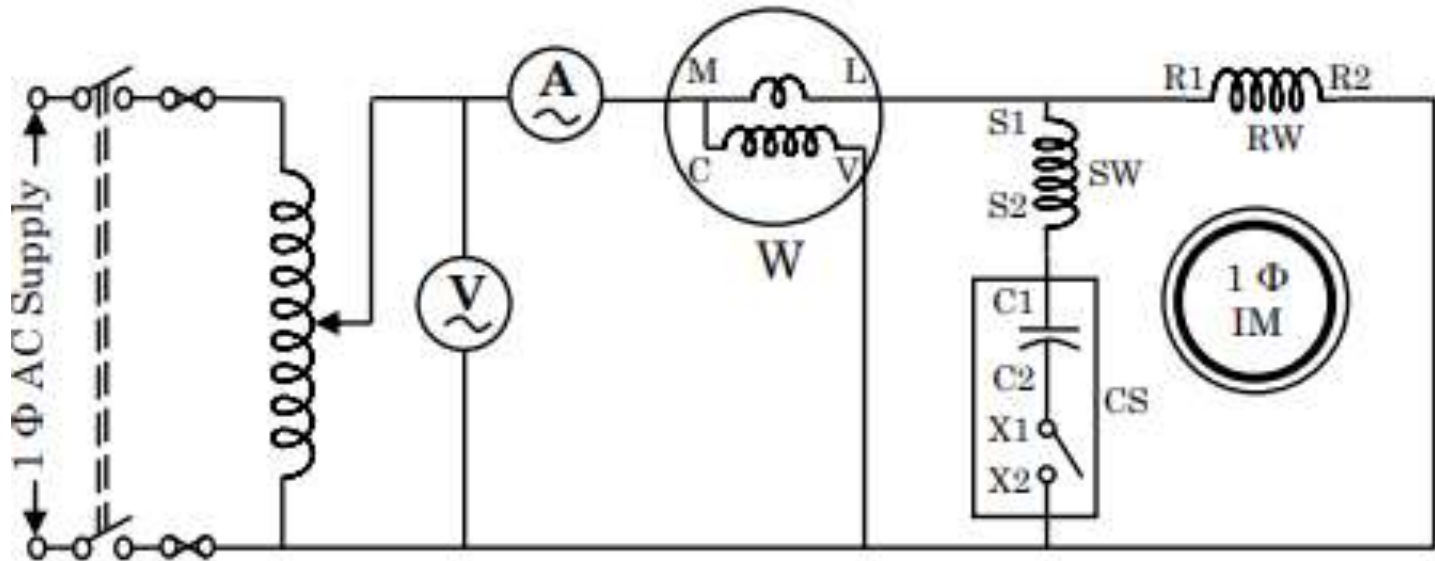

Experimental Table:

No-load Test			Blocked-rotor Test		
Voltage V_o (volt)	Current I_o (Amp)	Power Input W_o (watt)	Voltage V_{sc} (volt)	Current I_{sc} (Amp)	Power Input W_{sc} (watt)



SINGLE PHASE INDUCTION MOTOR

NO-LOAD AND BLOCKED ROTOR TEST ON AN INDUCTION MACHINE

CALCULATION

NO-LOAD TEST

V_o = No-load applied voltage.

I_o = Exciting current or No-load current

W_o = Core loss and Mechanical loss.

Therefore no load power factor

$$\cos\Phi = W_o / V_o \times I_o$$

So, the impedance is $Z_o = \frac{V_o}{I_o}$

reactance is $X_o = Z_o \sin\Phi_o$

$$R_o = r_1 + \frac{r_2}{2}$$

$$X_o = x_1 + \frac{1}{2}(x_2 + X_m)$$

BLOCKED ROTOR TEST

V_{sc} = Applied short circuit voltage on stator side.

I_{sc} = Short circuit current.

W_{sc} = Total ohmic loss.

$$R_{sc} = r_1 + 2\left(\frac{r_2}{2}\right) = \frac{W_{sc}}{I_{sc}^2}$$

Since resistance of main winding r_1 is already measured, effective rotor resistance $r_2 = R_{sc} - r_1$

$$Z_{sc} = \frac{V_{sc}}{I_{sc}}$$

$$X_{sc} = x_1 + 2\left(\frac{x_2}{2}\right) = \sqrt{Z_{sc}^2 - R_{sc}^2}$$

Since the leakage reactance x_1 and x_2 can't be separated out, it is assumed that $x_1 = x_2 = 1/2 X_{sc}$



SINGLE PHASE INDUCTION MOTOR

NO-LOAD AND BLOCKED ROTOR TEST ON AN INDUCTION MACHINE

CALCULATION

The total series impedance $Z = Z_1 + Z_f + Z_b$

So, the input current $I_m = \frac{V}{Z}$

Now, the core, friction and windage loss $P_r = W_o - I_o^2 R_o$

Therefore, output power $P_{out} = P_{mech} - P_r = [I_m^2 (R_f - R_b)(1-s)] - P_r$

And, input power $P_{in} = VI_m \cos \phi$

So, efficiency $\eta = \frac{P_{out}}{P_{in}} \times 100\%$

RESULT

Rotor resistance = Ω

Magnetizing reactance = Ω

Leakage reactance = Ω

Efficiency of induction motor = $\%$

Draw the equivalent circuit of single phase induction motor.



TOPIC:

**□ EQUIVALENT CIRCUIT OF
SINGLE_PHASE INDUCTION MOTOR**

**□ DETERMINATION OF EQUIVALENT
CIRCUIT PARAMETERS**

**Lecture:
04**

SINGLE PHASE INDUCTION MOTOR

EQUIVALENT CIRCUIT OF A SINGLE PHASE INDUCTION MOTOR

An induction motor is a well-known device which works on the principle of transformer. So it is also called the rotating transformer. That is, when an EMF is supplied to its stator, then as a result of electromagnetic induction, a voltage is induced in its rotor. So an induction motor is said to be a transformer with rotating secondary. Here, primary of transformer resembles stator winding of an induction motor and secondary resembles rotor.

The induction motor always runs below the synchronous or full load speed and the relative difference between the synchronous speed and speed of rotation is known as slip which is denoted by s .

$$s = \frac{(N_s - N)}{N_s}$$

Where, N_s is synchronous speed of rotation which is given by-

$$N_s = \frac{120f}{P}$$

The **Equivalent circuit** of a **Single Phase Induction Motor** can be obtained by two methods named as the Double Revolving Field Theory and Cross Field Theory. Firstly the equivalent circuit is developed on the basis of double revolving field theory when only its main winding is energized.



SINGLE PHASE INDUCTION MOTOR

EQUIVALENT CIRCUIT OF A SINGLE PHASE INDUCTION MOTOR

The equivalent circuit of any machine shows the various parameter of the machine such as its Ohmic losses and also other losses.

The losses are modeled just by inductor and resistor. The copper losses are occurred in the windings so the winding resistance is taken into account. Also, the winding has inductance for which there is a voltage drop due to inductive reactance and also a term called power factor comes into the picture. There are two types of equivalent circuits in case of a three-phase induction motor-

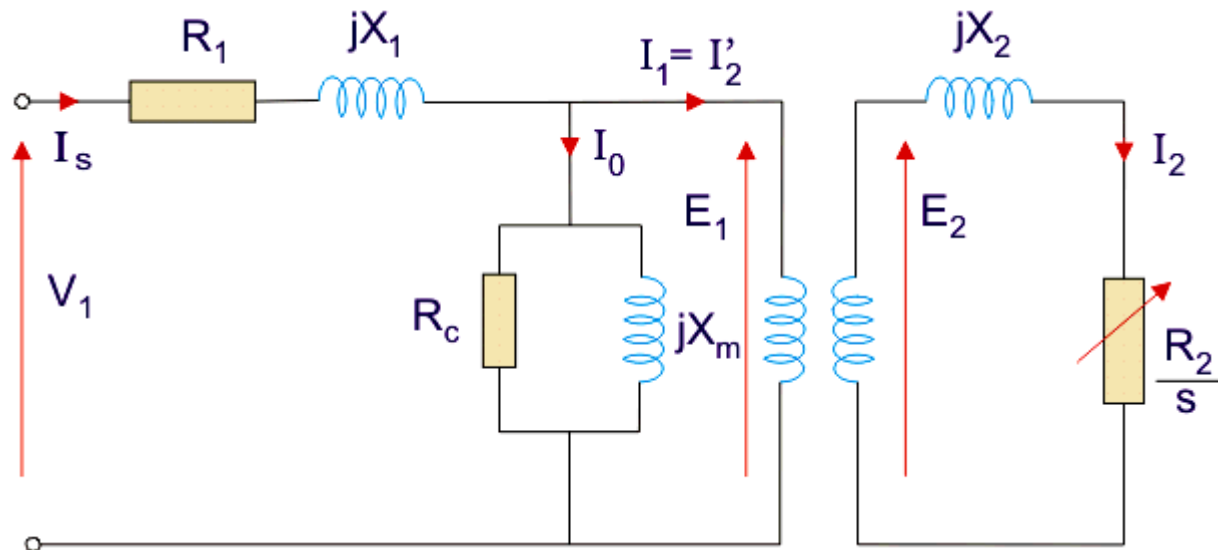

SINGLE PHASE INDUCTION MOTOR

EQUIVALENT CIRCUIT OF A SINGLE PHASE INDUCTION MOTOR

If we draw the circuit with referred to the stator then the circuit will look like-

Here,

R_1 is the winding resistance of the stator.

X_1 is the inductance of the stator winding.

R_c is the core loss component.

X_M is the magnetizing reactance of the winding.

R_2/s is the power of the rotor, which includes output mechanical power and copper loss of rotor.

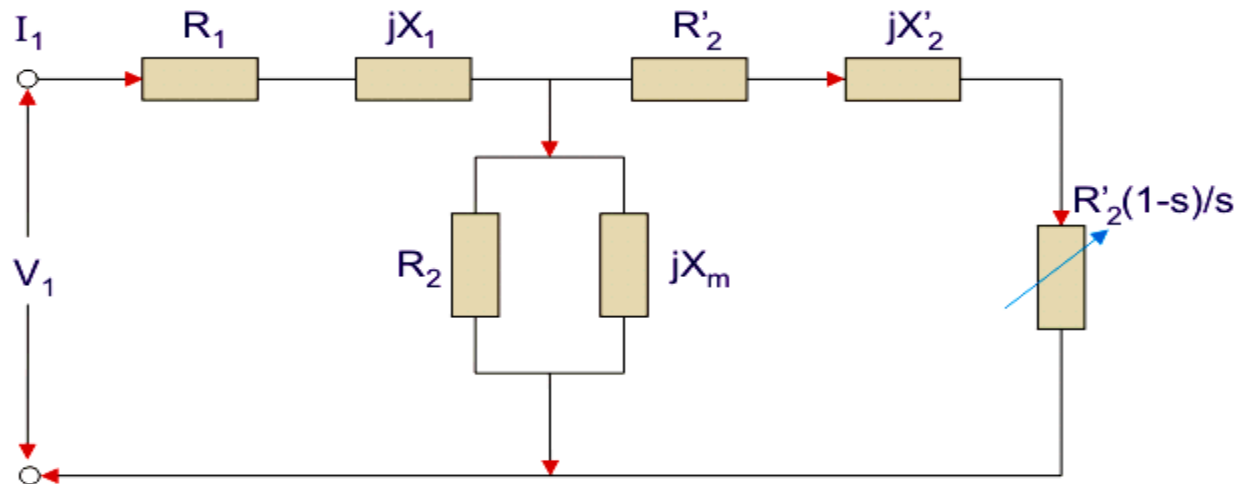

R_2' is the rotor winding resistance with referred to stator winding.

X_2' is the rotor winding inductance with referred to stator winding.

$R_2(1 - s) / s$ is the resistance which shows the power which is converted to mechanical power output or useful power. The power dissipated in that resistor is the useful power output or shaft power.



SINGLE PHASE INDUCTION MOTOR

EQUIVALENT CIRCUIT OF A SINGLE PHASE INDUCTION MOTOR

The equivalent circuit of a single phase induction motor can be developed on the basis of two revolving field theory. To develop the equivalent circuit it is necessary to consider standstill or blocked rotor conditions.

The motor with a blocked rotor merely acts like a transformer with its secondary short circuited, E_m being e.m.f. induced in the stator.

The motor may now be viewed from the point of view of the two revolving field theory. The two flux components induce e.m.f. E_m and E_{mb} in the respective stator winding. Since at standstill the two oppositely rotating fields are of same strength, the magnetizing and rotor impedances are divided into two equal halves connected in series.

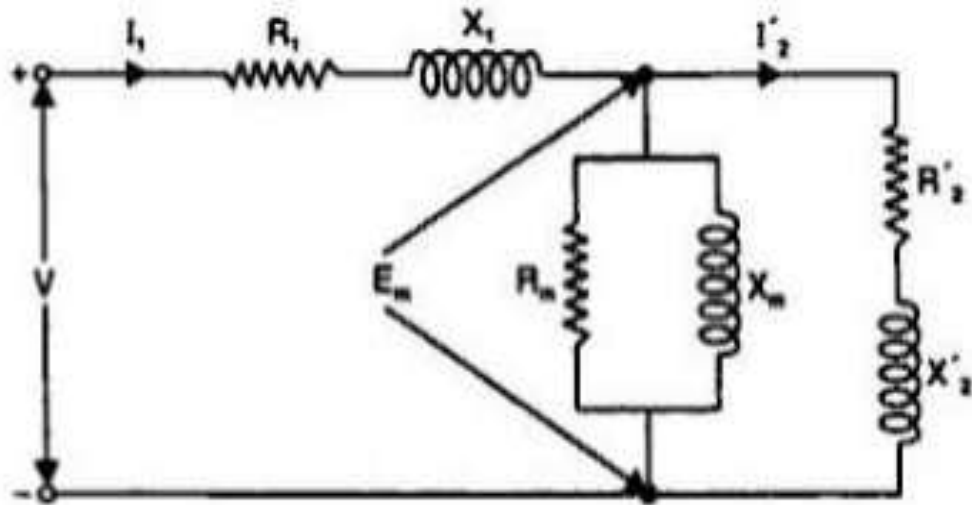

SINGLE PHASE INDUCTION MOTOR

EQUIVALENT CIRCUIT OF A SINGLE PHASE INDUCTION MOTOR

There is a difference between single phase and three phase equivalent circuits. The single phase induction motor circuit is given by double revolving field theory which states that

A stationary pulsating magnetic field might be resolved into two rotating fields, both having equal magnitude but opposite in direction. So the net torque induced is zero at standstill. Here, the forward rotation is called the rotation with slip s and the backward rotation is given with a slip of $(2 - s)$. The equivalent circuit is-

$$\text{Forward slip } S_f = \frac{(N_s - N_r)}{N_s}$$

$$\text{Backward slip} = \frac{(N_s + N_r)}{N_s} = 2 - S$$

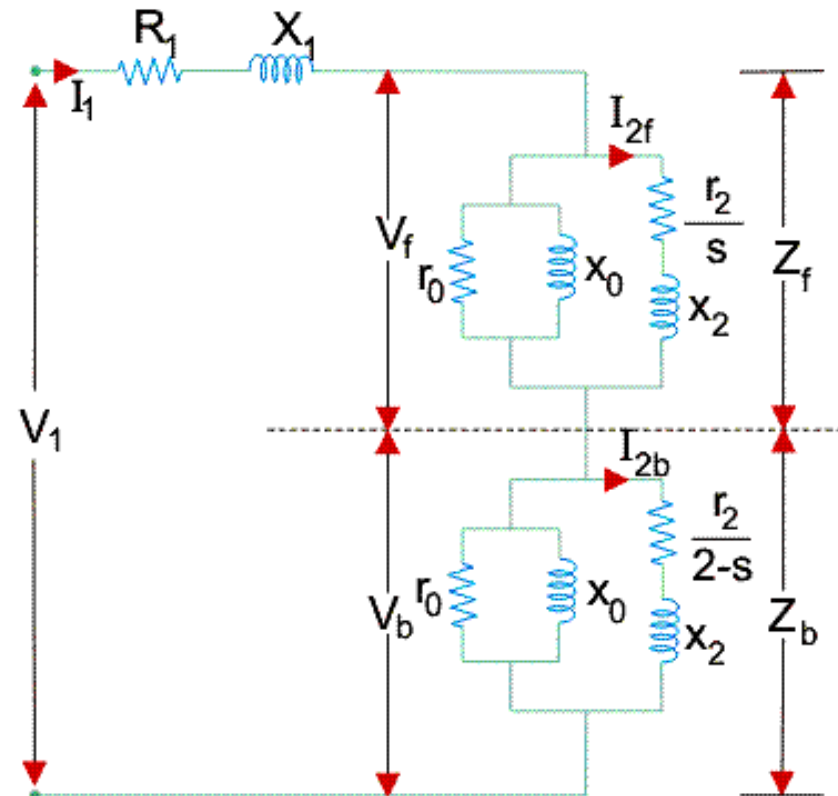

Induction motor (single phase) equivalent circuit referred to the stator



SINGLE PHASE INDUCTION MOTOR

EQUIVALENT CIRCUIT OF A SINGLE PHASE INDUCTION MOTOR

Equivalent Circuit of Single Phase Induction Motor at Standstill on the basis of Two Revolving Field Theory.

**At Standstill,
Slip=1**

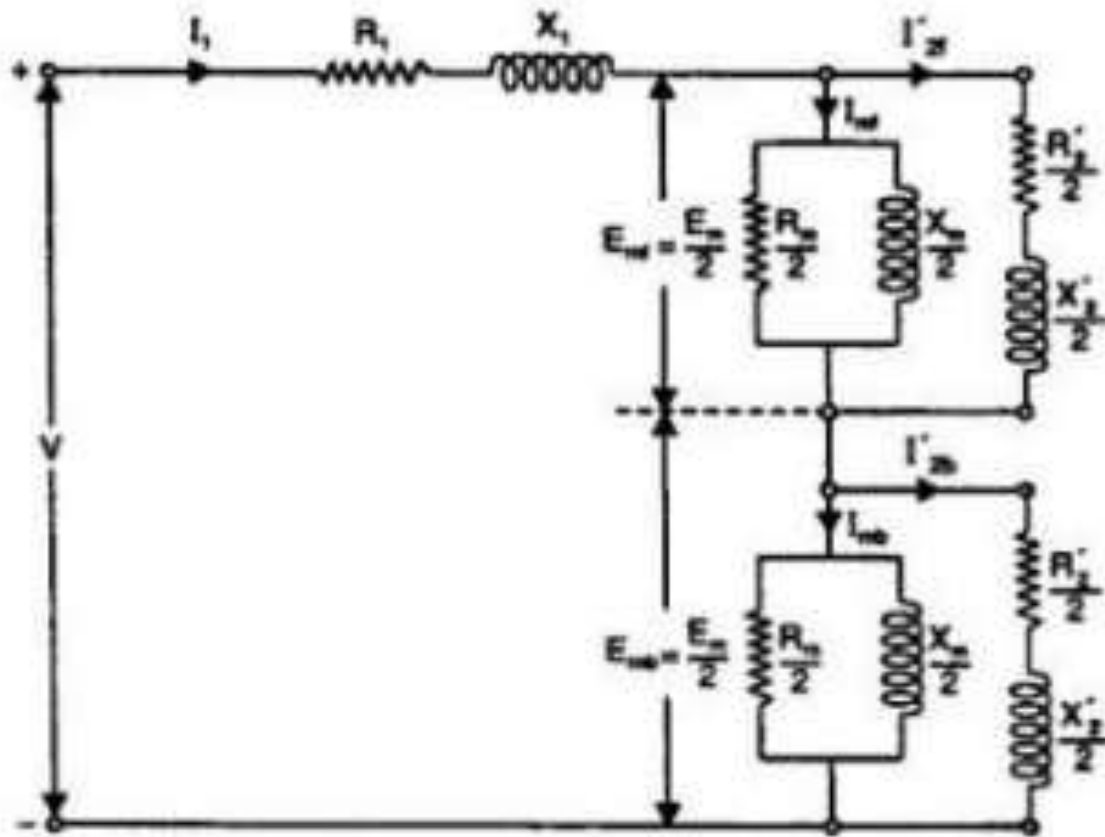

SINGLE PHASE INDUCTION MOTOR

EQUIVALENT CIRCUIT OF A SINGLE PHASE INDUCTION MOTOR

If the core losses are neglected the equivalent circuit is modified as shown in fig. The core losses, here, are handled as rotational losses and subtracted from the power converted into mechanical power; the amount of error thus introduced is relatively small.

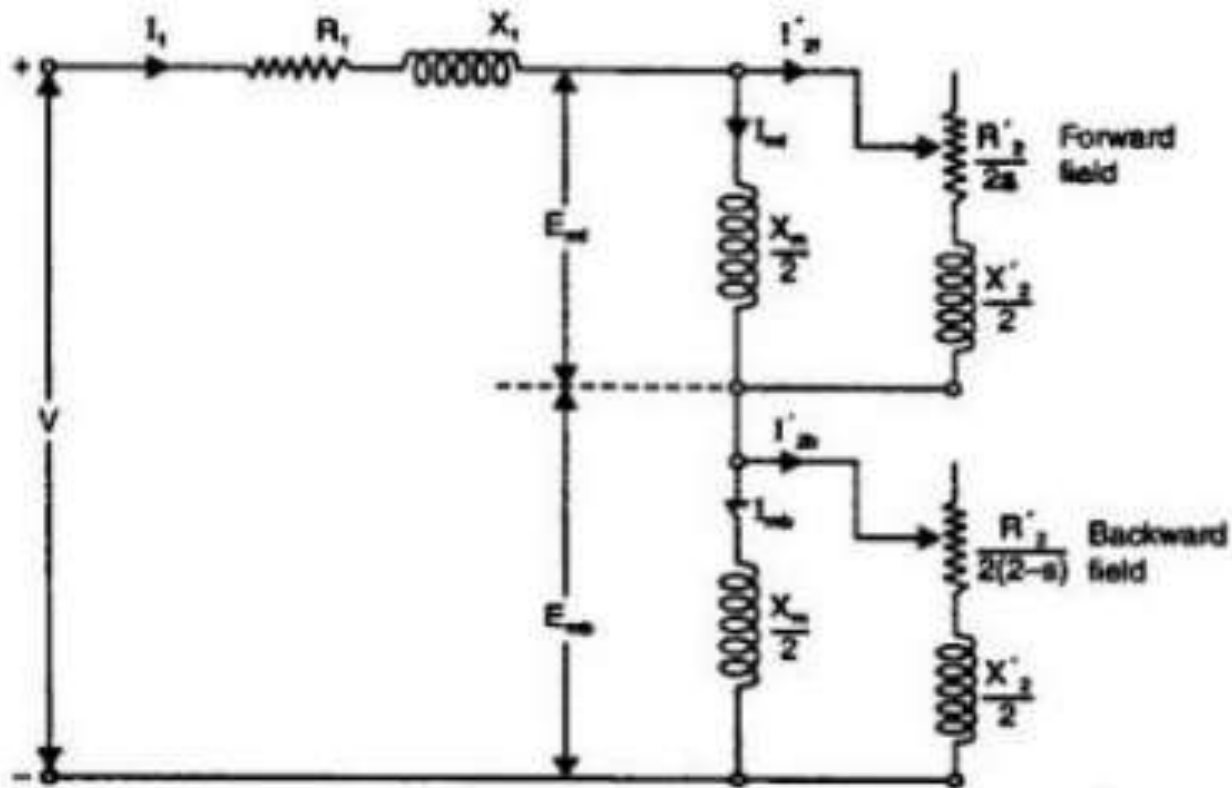

SINGLE PHASE INDUCTION MOTOR

EQUIVALENT CIRCUIT OF A SINGLE PHASE INDUCTION MOTOR

DETERMINATION OF EQUIVALENT CIRCUIT PARAMETERS OF SINGLE PHASE INDUCTION MOTOR

1. Without core loss

$$\frac{R'_2}{2s} + j \frac{1}{2} X'_2 \text{ parallel with } j \frac{X_M}{2}$$

$$\frac{R'_2}{2(2-s)} + j \frac{1}{2} X'_2 \text{ parallel with } j \frac{1}{2} X_M$$

$$Z_f = \frac{\left(\frac{R'_2}{2s} + j \frac{1}{2} X'_2 \right) \left(j \frac{1}{2} X_M \right)}{\frac{R'_2}{2s} + j \frac{1}{2} X'_2 + j \frac{1}{2} X_M}$$

$$Z_b = \frac{\left(\frac{R'_2}{2(2-s)} + j \frac{1}{2} X'_2 \right) \left(j \frac{1}{2} X_M \right)}{\frac{R'_2}{2(2-s)} + j \frac{1}{2} X'_2 + j \frac{1}{2} X_M}$$

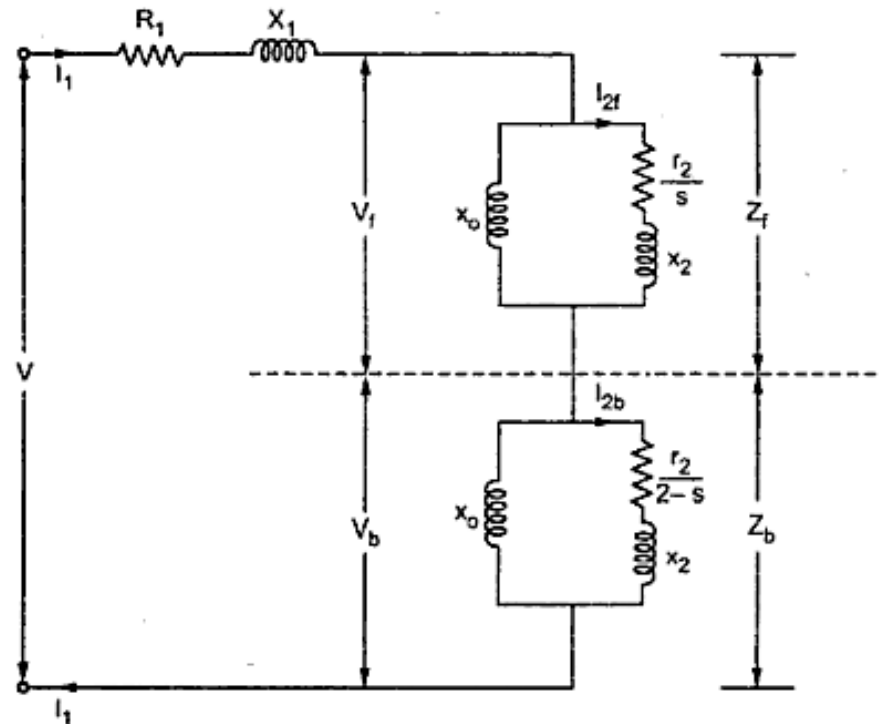

SINGLE PHASE INDUCTION MOTOR

EQUIVALENT CIRCUIT OF A SINGLE PHASE INDUCTION MOTOR

DETERMINATION OF EQUIVALENT CIRCUIT PARAMETERS OF SINGLE PHASE INDUCTION MOTOR

1. Without core loss

Under standstill condition, $s = 1$ and $2 - s = 1$ hence $Z_f = Z_b$ and hence $V_f = V_b$. But in the running condition, V_f becomes almost 90 to 95% of the applied voltage.

1. $Z_{eq} = Z_1 + Z_f + Z_b =$ Equivalent impedance

2. $I_{2f} = Vf / ((r_2/s) + j x_2)$ where $V_f = I_1 \times Z_f$
 $I_{2b} = Vb / ((r_2/2-s) + j x_2)$

I_{2f} = Current through forward rotor referred to stator

I_{2b} = Current through backward rotor referred to stator

3. $P_f =$ Power input to forward field rotor
 $= (I_{2f})^2 (r_2/s)$ watts

4. $T_f =$ forward torque $= P_f / (2\pi N/60)$ N-m

$T_b =$ backward torque $= P_b / (2\pi N/60)$ N-m

$P_b =$ Power input to backward field rotor
 $= (I_{2b})^2 (r_2/2-s)$ watts

$T =$ net torque $= T_f - T_b$

$P_m = (1 - s) \{$ Net power input $\}$
 $= (1 - s) (P_f - P_b)$ watts

$T_{sh} =$ shaft torque $= P_{out} / (2\pi N/60)$ N-m

$P_{out} = P_m -$ mechanical loss - core loss

5. $\% \eta = (\text{net output} / \text{net input}) \times 100$



SINGLE PHASE INDUCTION MOTOR

EQUIVALENT CIRCUIT OF A SINGLE PHASE INDUCTION MOTOR

DETERMINATION OF EQUIVALENT CIRCUIT PARAMETERS OF SINGLE PHASE INDUCTION MOTOR

1. With core loss

If the core loss is to be considered then it is necessary to connect a resistance in parallel with, in an exciting branch of each rotor is half the value of actual core loss resistance.

Z_{of} = Equivalent impedance of exciting branch in forward rotor

$$= r_o \parallel (j x_o)$$

and Z_{ob} = Equivalent impedance of exciting branch in backward rotor

$$= r_o \parallel (j x_o)$$

$$\therefore Z_f = Z_{of} \parallel (r_2/s + j x_2)$$

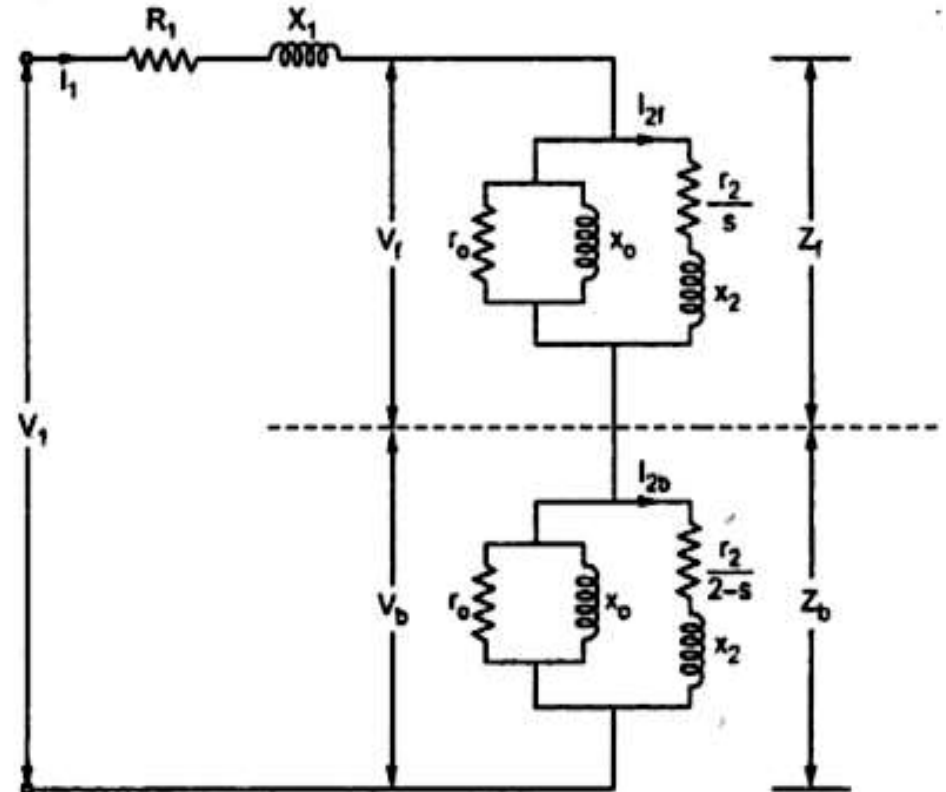

All other expressions remains same as stated earlier in case of equivalent circuit without core loss.



SINGLE PHASE INDUCTION MOTOR

EQUIVALENT CIRCUIT OF A SINGLE PHASE INDUCTION MOTOR

Calculation of Power of Equivalent Circuit

1. Find Z_f and Z_b .
2. Find stator current which is given by Stator voltage/Total circuit impedance.
3. Then find the input power which is given by
Stator voltage \times Stator current \times $\cos(\Theta)$
Where, Θ is the angle between the stator current and voltage.
4. Power Developed (P_g) is the difference between forward field power and backward power. The forward and backward power is given by the power dissipated in the respective resistors.
5. The rotor copper loss is given by- $s \times P_g$.
6. Output Power is given by-
 $P_g - s \times P_g - \text{Rotational loss.}$



TOPIC:

**☐ CAPACITOR START AND
CAPACITOR RUN INDUCTION MOTOR**

☐ SHADED POLE INDUCTION MOTOR

**Lecture:
03**

SINGLE PHASE INDUCTION MOTOR

STARTING METHODS OF SINGLE PHASE INDUCTION MOTOR

Capacitor Start Capacitor Run Motor

Single Phase Induction Motor Types – As far as normal running is concerned, a single winding is sufficient. But all motors must be self start. The auxiliary winding is provided to produce finite torque at standstill and is displaced in space with respect to the main winding. Current in second winding is supplied from same Single Phase source as the main winding, but is caused to have a phase difference by various methods which are discussed later. The combination of a space displacement between the two windings together with a time displacement between the currents, produces a machine which has a finite torque at standstill, and therefore, it can self start. Such a motor can be reversed by changing the phase sequence, which requires that polarity of one of the windings be reversed.

Earlier it was a common practice to use the auxiliary winding only during start and run-up. It used to be disconnected with the help of a centrifugal switch, or relay once the motor speed reaches around 75% of the full speed. In such an arrangement auxiliary winding can have lower rating and its parameters can be chosen to improve the starting performance. But then switching arrangement is a disadvantage. Present practice is to use auxiliary winding all the time but then its parameters are to be chosen to provide a compromise between starting and running performance and its rating has to be chosen on continuous basis.



SINGLE PHASE INDUCTION MOTOR

STARTING METHODS OF SINGLE PHASE INDUCTION MOTOR

Capacitor Start Capacitor Run Motor

The Capacitor Start Capacitor Run Motor has a cage rotor, and its stator has two windings known as Main and Auxiliary Windings. The two windings are displaced 90 degrees in space. There are two capacitors in this method one is used at the time of the starting and is known as starting capacitor. The other one is used for continuous running of the motor and is known as RUN capacitor.

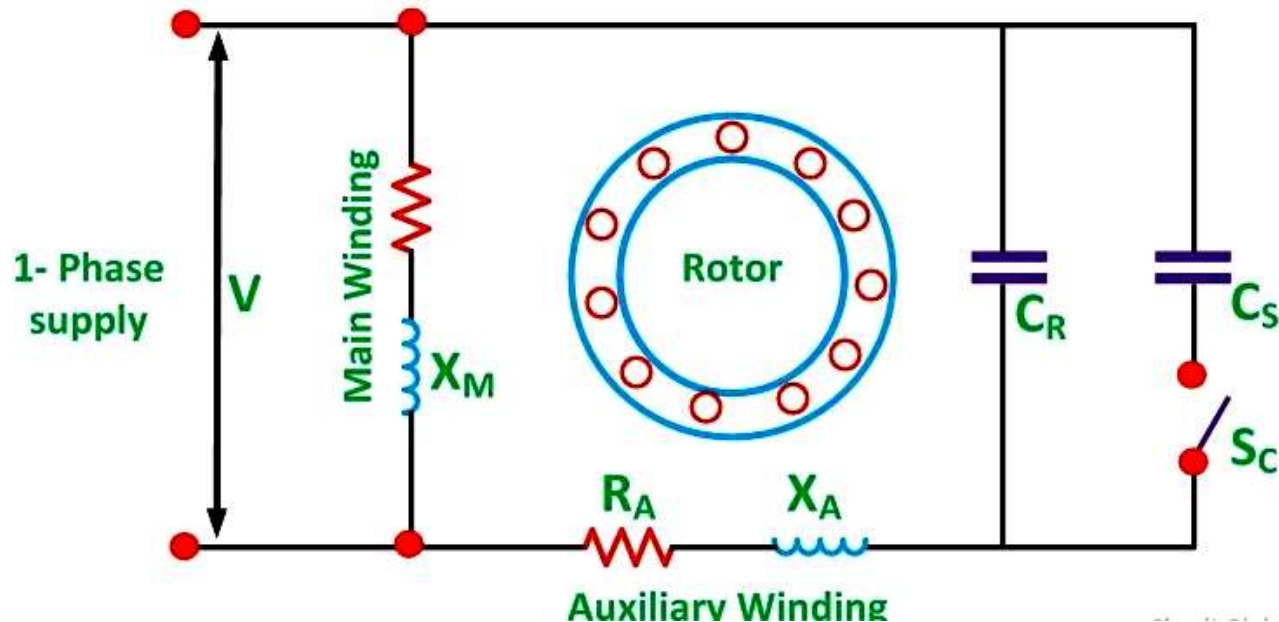

SINGLE PHASE INDUCTION MOTOR

STARTING METHODS OF SINGLE PHASE INDUCTION MOTOR

Capacitor Start Capacitor Run Motor

So this motor is named as Capacitor Start Capacitor Run Motor. This motor is also known as Two Value Capacitor Motor. Connection diagram of the **Two value Capacitor Motor**

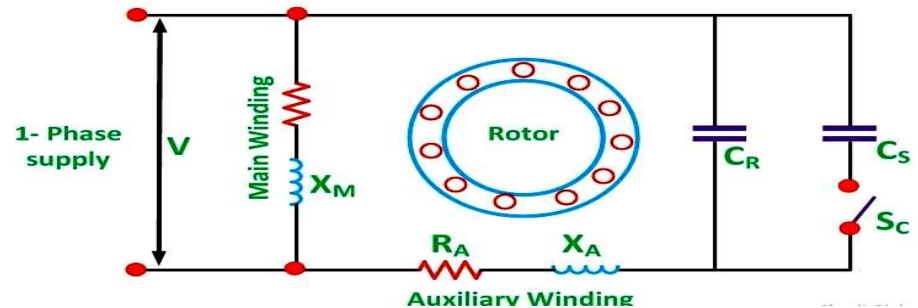

There are two capacitors in this motor represented by C_S and C_R . At the starting, the two capacitors are connected in parallel. The Capacitor C_S is the Starting capacitor is short time rated. It is almost electrolytic. A large amount of current is required to obtain the starting torque. Therefore, the value of the capacitive reactance X should be low in the starting winding. Since, $X_A = 1/2\pi f C_A$, the value of the starting capacitor should be large.

The rated line current is smaller than the starting current at the normal operating condition of the motor. Hence, the value of the capacitive reactance should be large. Since, $X_R = 1/2\pi f C_R$, the value of the run capacitor should be small.

As the motor reaches the synchronous speed, the starting capacitor C_S is disconnected from the circuit by a centrifugal switch S_C . The capacitor C_R is connected permanently in the circuit and thus it is known as RUN Capacitor. The run capacitor is long time rated and is made of oil filled paper.



SINGLE PHASE INDUCTION MOTOR

STARTING METHODS OF SINGLE PHASE INDUCTION MOTOR

Capacitor Start Capacitor Run Motor

Working of Capacitor Start Capacitor Run Induction Motor

The capacitors C_s and C_r are connected parallel during motor starting.

C_s = start capacitor

C_r = run capacitor

R_m = main winding resistance

X_m = main winding inductive reactance

R_a = series resistor connected in the auxiliary winding

X_a = auxiliary winding inductive reactance

S = centrifugal switch

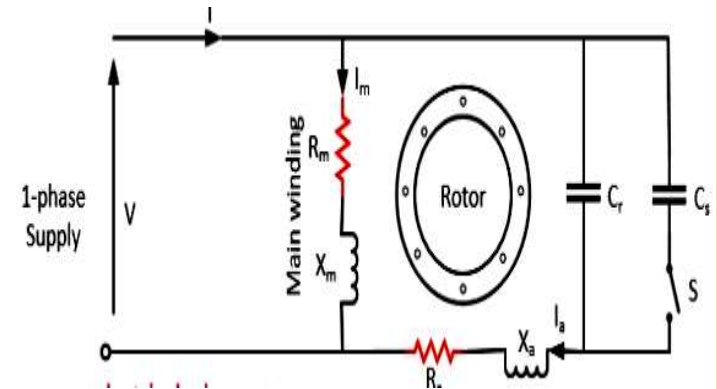

When the stator windings are energized from a 1-phase supply, the main winding carries current I_m and the starting winding carries current I_a . During starting, high torque is required. For high torque, a high current is required. In order to draw high current, the auxiliary winding capacitance reactance should be low. As capacitive reactance is given by

$$X_s = 1/(2\pi f C_s)$$

To have low X_s , C_s should be large.

During normal working, the line current required is small. In order to draw low current, the auxiliary winding capacitance reactance should be large. As capacitive reactance is given by

$$X_r = 1/(2\pi f C_r)$$

To have large X_r , C_r should be low.

SINGLE PHASE INDUCTION MOTOR

STARTING METHODS OF SINGLE PHASE INDUCTION MOTOR

Capacitor Start Capacitor Run Motor

Working of Capacitor Start Capacitor Run Induction Motor

The capacitors C_s and C_r are connected in parallel during motor starting. The value of the capacitor C_s is chosen such that current I_m is made to lag current I_a by greater than 90° . Therefore, there is a time-phase difference (α) and 90° space difference between the two currents. These two currents produce a rotating magnetic field which starts the motor.

When the motor reaches speed about 70 to 80 % of synchronous speed, the capacitor C_s disconnects from the supply by centrifugally operated switch S . The capacitor C_r is permanently connected to the circuit.

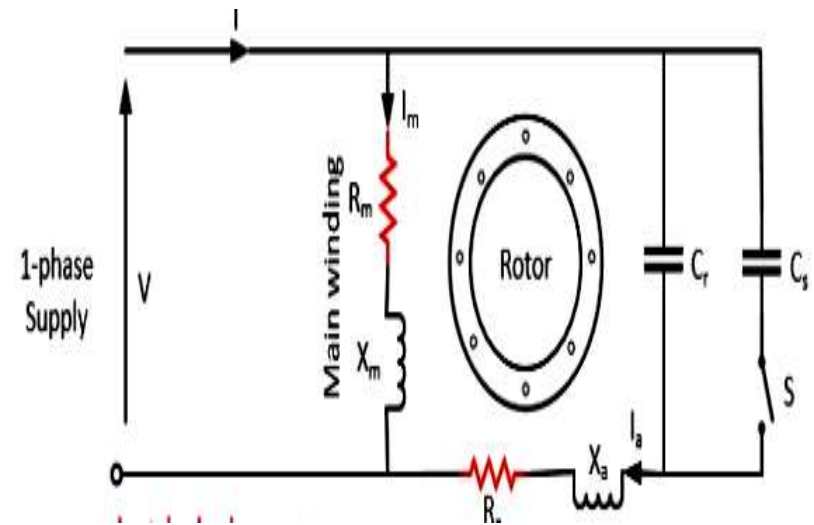

SINGLE PHASE INDUCTION MOTOR

STARTING METHODS OF SINGLE PHASE INDUCTION MOTOR

Capacitor Start Capacitor Run Motor

The **Phasor Diagram** of the Capacitor Start Capacitor Run Motor.

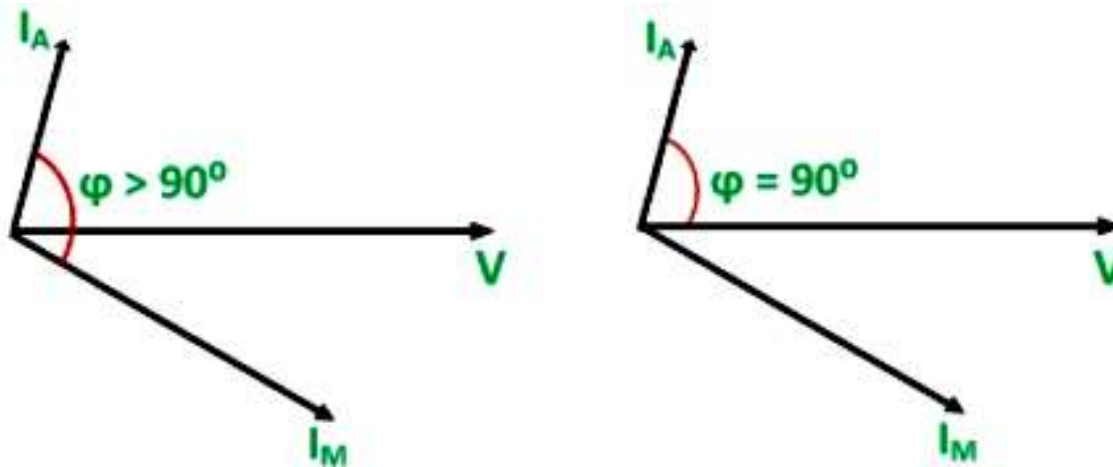

Fig(a) shows the phasor diagram when at the starting both the capacitor are in the circuit and $\phi > 90^\circ$. Fig (b) shows the phasor when the starting capacitor is disconnected, and ϕ becomes equal to 90° .



SINGLE PHASE INDUCTION MOTOR

STARTING METHODS OF SINGLE PHASE INDUCTION MOTOR

Capacitor Start Capacitor Run Motor

The **Torque Speed Characteristic** of a Two Value Capacitor Motor

This type of motor is quiet and smooth running. They have higher efficiency than the motors that run on the main windings only. They are used for loads of higher inertia requiring frequent starts where the maximum pull-out torque and efficiency required are higher. The Two Value Capacitor Motors are used in pumping equipment, refrigeration, air compressors, etc.

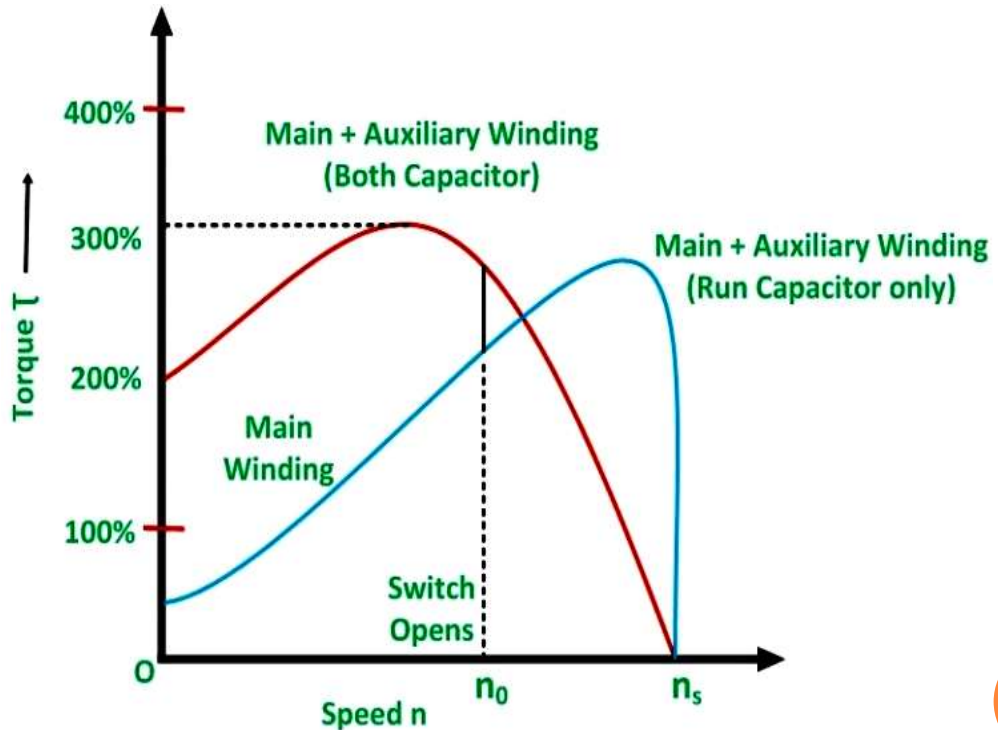

SINGLE PHASE INDUCTION MOTOR

STARTING METHODS OF SINGLE PHASE INDUCTION MOTOR

Capacitor Start Capacitor Run Motor

1. The reversal of the direction of rotation of this motor is possible by reversing the line connections of either main winding or the auxiliary winding. This can be done when the motor is at standstill condition.
2. The starting torque is high.
3. The motor has very less noise. Also motor runs smoothly.
4. These Motors are costly.
5. They have higher efficiency than motors running on main winding alone.
6. Start Capacitor C_s is short-time rated and has electrolytic construction.
7. Run Capacitor C_r is long-time rated and has oil filled paper construction.



SINGLE PHASE INDUCTION MOTOR

STARTING METHODS OF SINGLE PHASE INDUCTION MOTOR



Shaded Pole Induction Motor

The shaded pole induction motor is simply a self-starting single-phase induction motor whose one of the pole is shaded by the copper ring. The copper ring is also called the shaded ring. This copper ring act as a secondary winding for the motor. The shaded pole motor rotates only in one particular direction, and the reverse movement of the motor is not possible.

The magnetic field induced in the main poles is induced into the shaded coil by means of an Induction Principle. The magnetic flux produced is an alternating field. The flux induced in the shaded coil opposes the flux of the main pole. During the positive cycle, the flux opposition is more towards the main field and vice-versa during the negative cycle. Thus, a rotating magnetic field is developed due to the field oppositions during the entire cycle. Therefore, a unique torque is developed which is able to rotate the rotor.

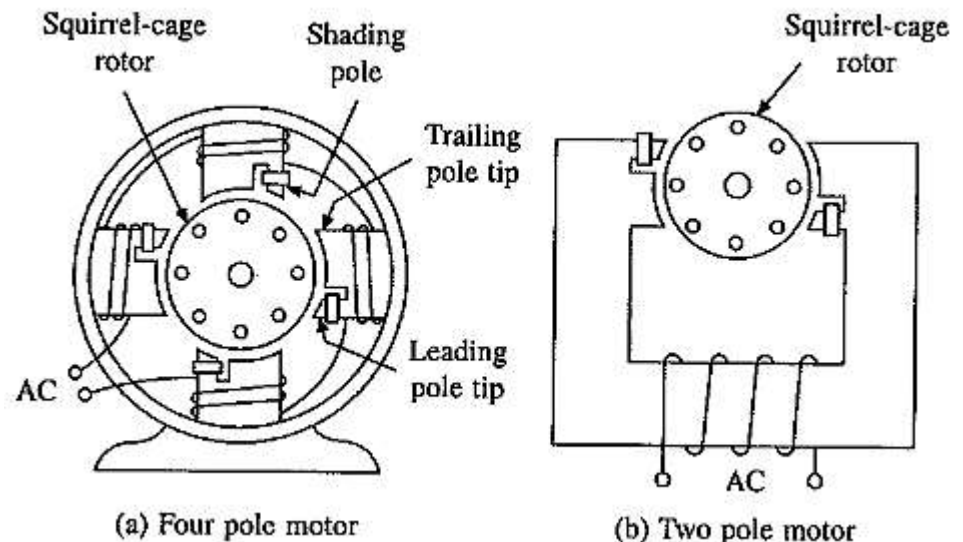

SINGLE PHASE INDUCTION MOTOR

STARTING METHODS OF SINGLE PHASE INDUCTION MOTOR

Shaded Pole Induction Motor

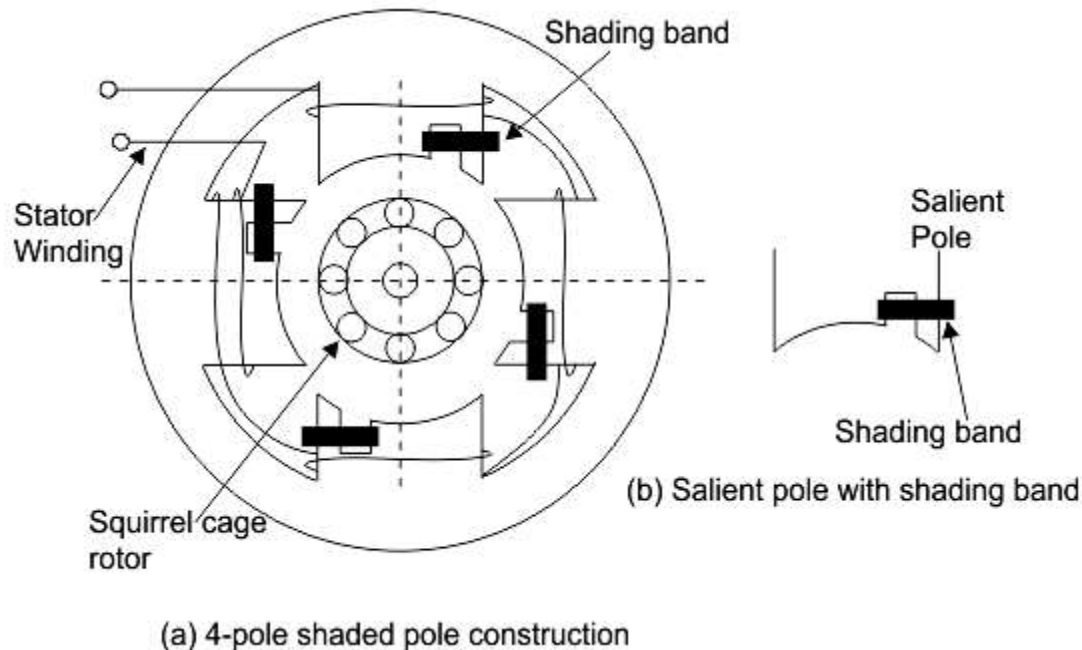

The stator of the **shaded pole single phase induction motor** has salient or projected poles. These poles are shaded by copper band or ring which is inductive in nature. The poles are divided into two unequal halves. The smaller portion carries the copper band and is called as shaded portion of the pole.



SINGLE PHASE INDUCTION MOTOR

STARTING METHODS OF SINGLE PHASE INDUCTION MOTOR

Shaded Pole Induction Motor

Working Principle

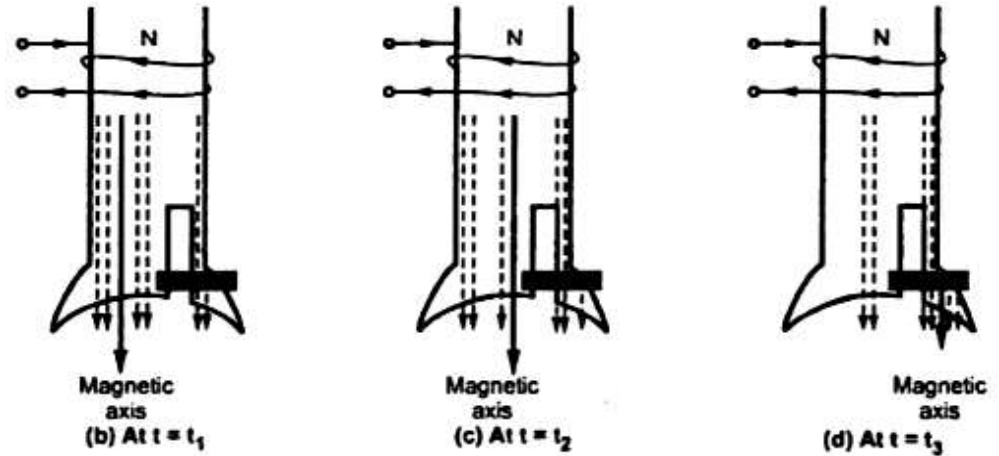
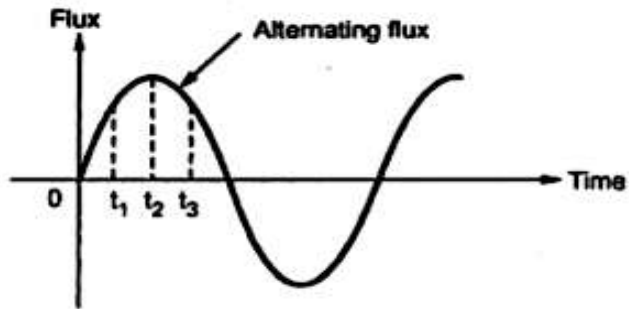

When a single phase supply is given to the stator of shaded pole induction motor an alternating flux is produced. This change of flux induces emf in the shaded coil. Since this shaded portion is short circuited, the current is produced in it in such a direction to oppose the main flux. The flux in shaded pole lags behind the flux in the unshaded pole. The phase difference between these two fluxes produces resultant rotating flux.

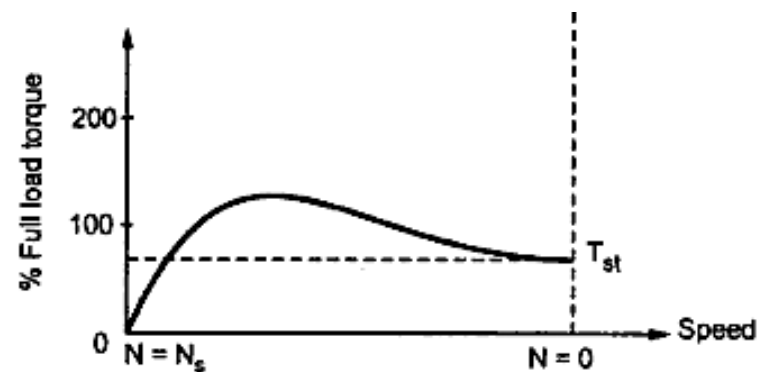

SINGLE PHASE INDUCTION MOTOR

STARTING METHODS OF SINGLE PHASE INDUCTION MOTOR

Shaded Pole Induction Motor

Construction of Shaded Pole Induction Motor

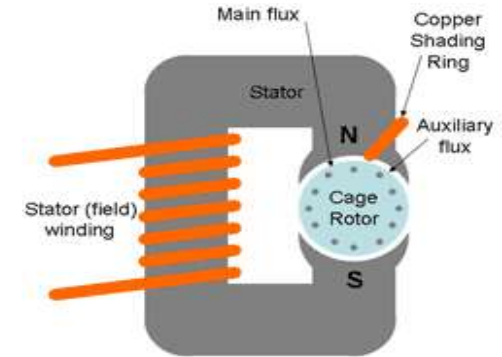

Stator – The stator of the shaded pole motor has a salient pole. The salient pole means the poles of the magnet are projected towards the armature of the motor. Each pole of the motor is excited by its exciting coil. The copper rings shade the loops. The loops are known as the shading coil.

The poles of the motor are laminated. The lamination means multiple layers of material are used for making the poles. So, that the strength of the pole increases.

The slot is constructed at some distance apart from the edge of the poles. The short-circuited copper coil is placed in this slot. The part which is covered with the copper ring is called the shaded part and which are not covered by the rings are called unshaded part.

Rotor – The shaded pole motor uses the squirrel cage rotor. The bars of the rotor is skewed at an angle of 60° . The skew can be done for obtaining the better starting torque.

The construction of the motor is very simple because it does not contain any commutator, brushes, collector rings, etc. or any other part. The shaded pole induction motor does not have any centrifugal switch. Thus, the chances of failure of the motor are less.

The centrifugal switch is the type of electrical switch that starts operating by using the centrifugal force, generated by the rotating shaft. It is also used for controlling the speed of the shaft.



SINGLE PHASE INDUCTION MOTOR

STARTING METHODS OF SINGLE PHASE INDUCTION MOTOR

Shaded Pole Induction Motor

Advantages and Disadvantages of Shaded Pole Motor

The advantages of shaded pole induction motor are

1. Very economical and reliable.
2. Construction is simple and robust because there is no centrifugal switch.

The disadvantages of shaded pole induction motor are

1. Low power factor.
2. The starting torque is very poor.
3. The efficiency is very low as, the copper losses are high due to presence of copper band.



SINGLE PHASE INDUCTION MOTOR

STARTING METHODS OF SINGLE PHASE INDUCTION MOTOR

Shaded Pole Induction Motor

Applications of the Shaded Pole Induction Motor

The various applications of the Shaded Poles Motor are as follows:-

1. They are suitable for small devices like relays and fans because of its low cost and easy starting.
2. Used in exhaust fans, hair dryers and also in table fans.
3. Used in air conditioning and refrigeration equipment and cooling fans.
4. Record players, tape recorders, projectors, photocopying machines.
5. Used for starting electronic clocks and single-phase synchronous timing motors.

This type of motor is used to drive the devices which require low starting torque.



SINGLE PHASE INDUCTION MOTOR

STARTING METHODS OF SINGLE PHASE INDUCTION MOTOR

Limitation of Shaded Pole Induction Motor

Due to absence of centrifugal switch the construction is simple and robust but this type of motor has a lot of limitation as :

1. The starting torque is poor.
2. The power factor is very low.
3. Due to I^2R , copper losses in the shading ring the efficiency is very low.
4. The speed reversal is very difficult. To achieve the speed reversal, the additional set of shading rings is required. By opening one set and closing other, direction can be reversed but the method is complicated and expensive.
5. The size and power rating of these motors is very small. These motors are usually available in a range of 1/300 to 1/20 kW.



TOPIC:

- ❑ **WORKING PRINCIPLE OF A SINGLE PHASE INDUCTION MOTOR**
- ❑ **STARTING METHODS OF SINGLE PHASE INDUCTION MOTOR**

**Lecture:
02**

SINGLE PHASE INDUCTION MOTOR

WORKING PRINCIPLE OF A SINGLE PHASE INDUCTION MOTOR

A **Single Phase Induction Motor** consists of a single phase winding which is mounted on the stator of the motor and a cage winding placed on the rotor. A pulsating magnetic field is produced, when the stator winding of the single-phase induction motor shown below is energized by a single phase supply.

The word Pulsating means that the field builds up in one direction falls to zero and then builds up in the opposite direction. Under these conditions, the rotor of an induction motor does not rotate. Hence, a single phase induction motor is not self-starting. It requires some special starting means.

If the 1 phase stator winding is excited and the rotor of the motor is rotated by an auxiliary means and the starting device is then removed, the motor continues to rotate in the direction in which it is started.

The performance of the single phase induction motor is analyzed by the two theories. One is known as the **Double Revolving Field Theory**, and the other is **Cross Field Theory**. Both the theories are similar and explain the reason for the production of torque when the rotor is rotating.

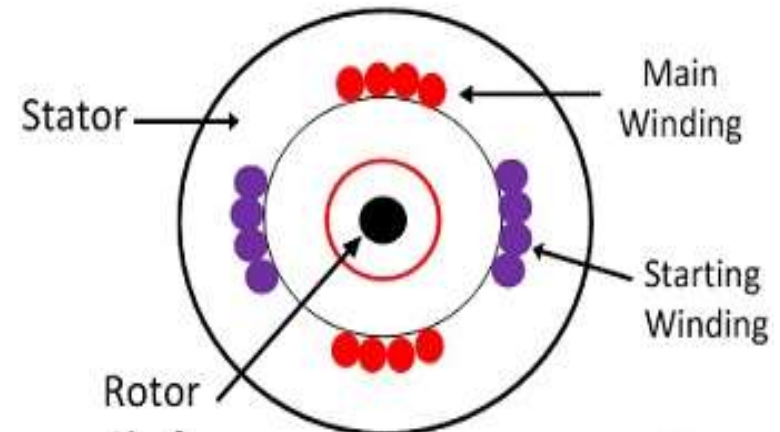

SINGLE PHASE INDUCTION MOTOR

STARTING METHODS OF SINGLE PHASE INDUCTION MOTOR

The single-phase IM has no starting torque, but has resultant torque, when it rotates at any other speed, except synchronous speed. It is also known that, in a balanced two-phase IM having two windings, each having equal number of turns and placed at a space angle of (electrical), and are fed from a balanced two-phase supply, with two voltages equal in magnitude, at an angle of , the rotating magnetic fields are produced, as in a three-phase IM. The torque-speed characteristic is same as that of a three-phase one, having both starting and also running torque.

So, in a single-phase IM, if an auxiliary winding is introduced in the stator, in addition to the main winding, but placed at a space angle of (electrical), starting torque is produced. The currents in the two (main and auxiliary) stator windings also must be at an angle of , to produce maximum starting torque, as shown in a balanced two-phase stator. Thus, rotating magnetic field is produced in such motor, giving rise to starting torque.

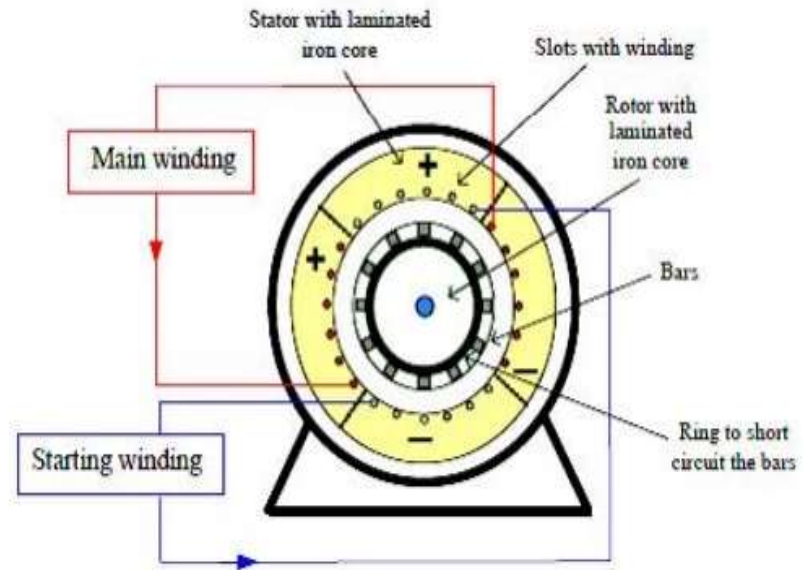

SINGLE PHASE INDUCTION MOTOR

STARTING METHODS OF SINGLE PHASE INDUCTION MOTOR

1. Single-phase Induction Motors:

A. Split-phase motors

(i) Resistance-start motor

(ii) Capacitor-start motor

(iii) Permanent-split (single-value) capacitor motor

(iv) Two-value capacitor motor.

B. Shaded-pole induction motor.

C. Reluctance-start induction motor.

D. Repulsion-start induction motor.

2. Commutator-Type, Single-Phase Motors:

A. Repulsion motor.

B. Repulsion-induction motor.

C. A.C series motor.

D. Universal motor.

3. Single-phase Synchronous Motors:

A. Reluctance motor.

B. Hysteresis motor.

C. Sub-synchronous motor



SINGLE PHASE INDUCTION MOTOR

STARTING METHODS OF SINGLE PHASE INDUCTION MOTOR

Split Phase Induction Motor

The Split Phase Motor is also known as a Resistance Start Motor. It has a single cage rotor, and its stator has two windings known as main winding and starting winding. Both the windings are displaced 90 degrees in space. The main winding has very low resistance and a high inductive reactance whereas the starting winding has high resistance and low inductive reactance.

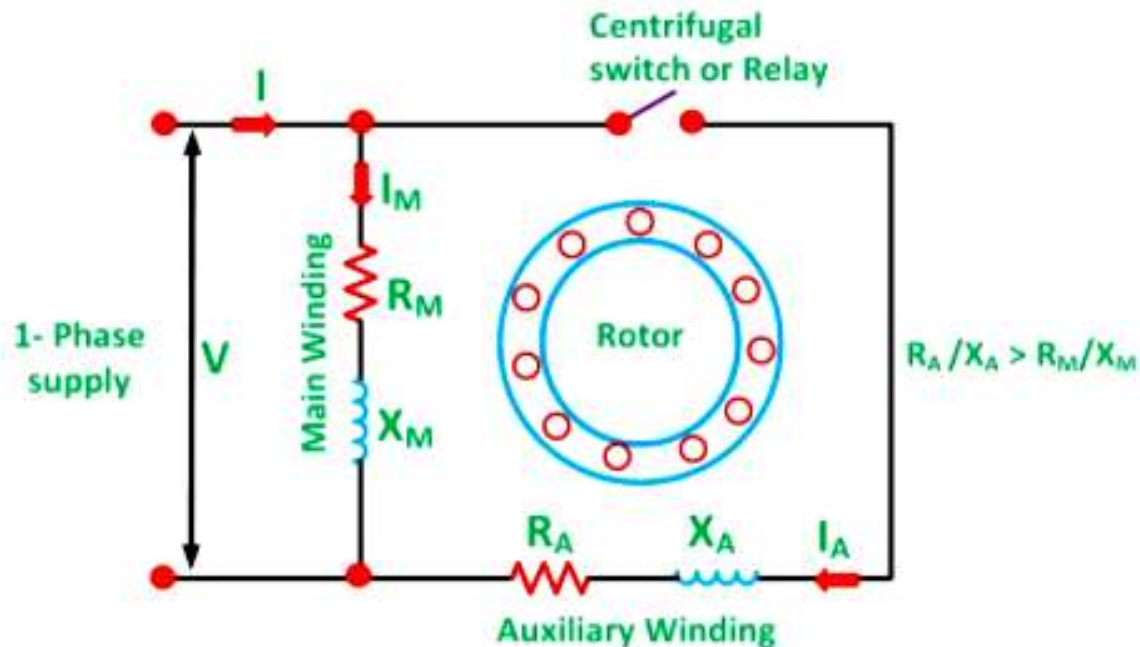

SINGLE PHASE INDUCTION MOTOR

STARTING METHODS OF SINGLE PHASE INDUCTION MOTOR

Split Phase Induction Motor

A resistor is connected in series with the auxiliary winding. The current in the two windings is not equal as a result the rotating field is not uniform. Hence, the starting torque is small, of the order of 1.5 to 2 times of the started running torque. At the starting of the motor both the windings are connected in parallel.

As soon as the motor reaches the speed of about 70 to 80 % of the synchronous speed the starting winding is disconnected automatically from the supply mains. If the motors are rated about 100 Watt or more, a centrifugal switch is used to disconnect the starting winding and for the smaller rating motors relay is used for the disconnecting of the winding.

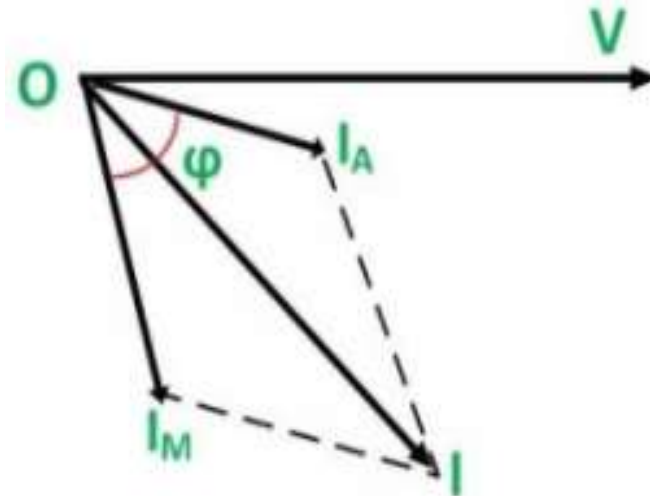

A relay is connected in series with the main winding. At the starting, the heavy current flows in the circuit, and the contact of the relay gets closed. Thus, the starting winding is in the circuit, and as the motor attains the predetermined speed, the current in the relay starts decreasing. Therefore, the relay opens and disconnects the auxiliary winding from the supply, making the motor runs on the main winding only.



SINGLE PHASE INDUCTION MOTOR

STARTING METHODS OF SINGLE PHASE INDUCTION MOTOR

Split Phase Induction Motor

The **Torque Speed Characteristic** of the Split Phase motor

Here, n_0 is the point at which the centrifugal switch operates. The starting torque of the resistance start motor is about 1.5 times of the full load torque. The maximum torque is about 2.5 times of the full load torque at about 75% of the synchronous speed. The starting current of the motor is high about 7 to 8 times of the full load value.

The direction of the Resistance Start motor can be reversed by reversing the line connection of either the main winding or the starting winding. The reversal of the motor is possible at the standstill condition only.

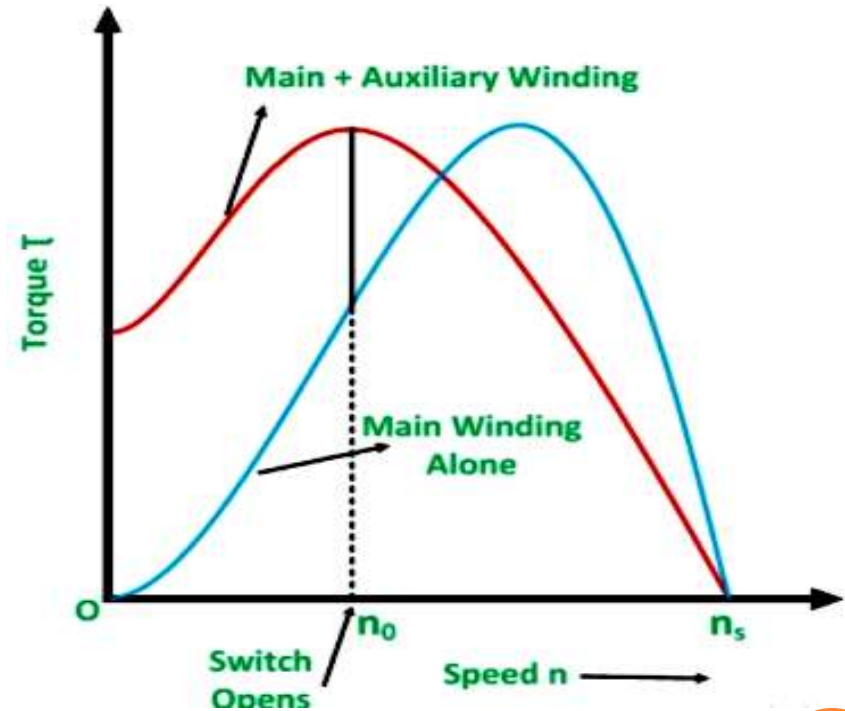

SINGLE PHASE INDUCTION MOTOR

STARTING METHODS OF SINGLE PHASE INDUCTION MOTOR

Split Phase Induction Motor

Applications of Split Phase Induction Motor

This type of motors are cheap and are suitable for easily starting loads where the frequency of starting is limited. This type of motor is not used for drives which require more than 1 KW because of the low starting torque. The various applications are as follows:-

1. Used in the washing machine, and air conditioning fans.
2. The motors are used in mixer grinder, floor polishers.
3. Blowers, Centrifugal pumps.
4. Drilling and lathe machine.



SINGLE PHASE INDUCTION MOTOR

STARTING METHODS OF SINGLE PHASE INDUCTION MOTOR

Capacitor Start Induction Motor

A Capacitor Start Motors are a single phase Induction Motor that employs a capacitor in the auxiliary winding circuit to produce a greater phase difference between the current in the main and the auxiliary windings. The name capacitor starts itself shows that the motor uses a capacitor for the purpose of the starting. The figure below shows the connection diagram of a Capacitor Start Motor.

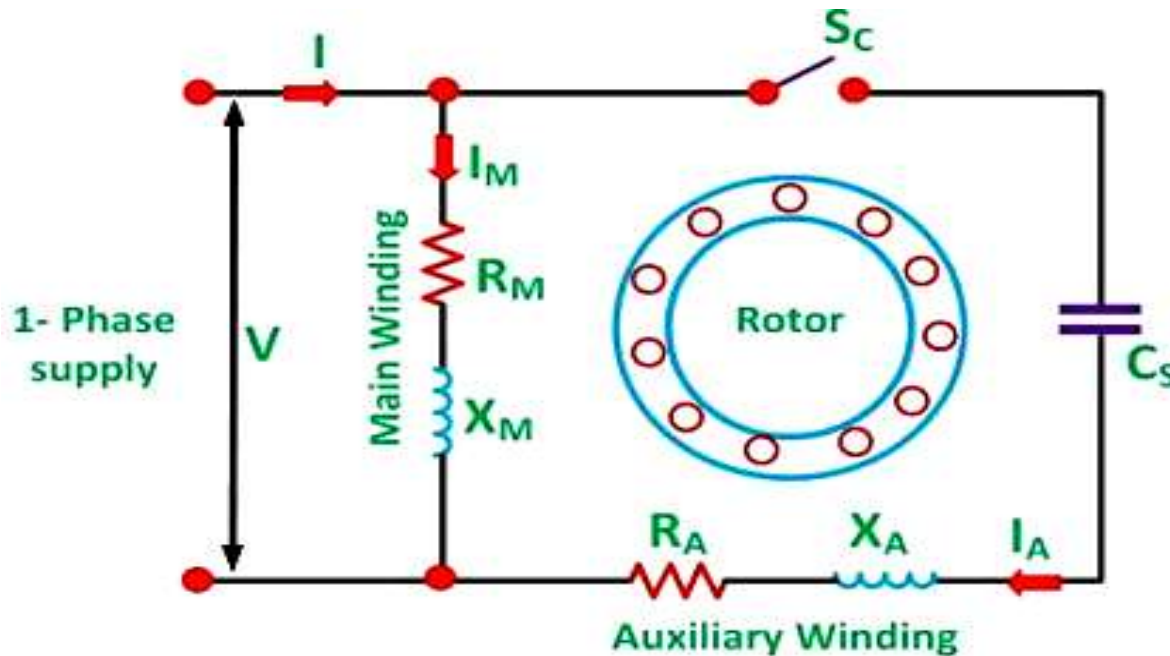

SINGLE PHASE INDUCTION MOTOR

STARTING METHODS OF SINGLE PHASE INDUCTION MOTOR

Capacitor Start Induction Motor

The capacitor start motor has a cage rotor and has two windings on the stator. They are known as the main winding and the auxiliary or the starting winding. The two windings are placed 90 degrees apart. A capacitor C_s is connected in series with the starting winding. A centrifugal switch S_C is also connected in the circuit.

I_M is the current in the main winding which is lagging the auxiliary current I_A by 90 degrees as shown in the phasor diagram above. Thus, a single phase supply current is split into two phases. The two windings are displaced apart by 90 degrees electrical, and their MMF's are equal in magnitude but 90 degrees apart in time phase.

The motor acts as a balanced two-phase motor. As the motor approaches its rated speed, the auxiliary winding and the starting capacitor is disconnected automatically by the centrifugal switch provided on the shaft of the motor.

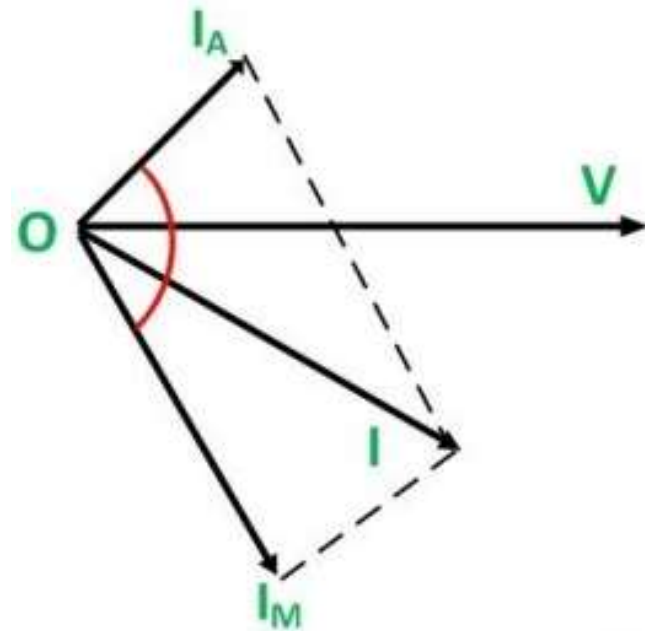

SINGLE PHASE INDUCTION MOTOR

STARTING METHODS OF SINGLE PHASE INDUCTION MOTOR

Capacitor Start Induction Motor

The **Torque Speed Characteristic** of the motor is

The characteristic shows that the starting torque is high. The cost of this motor is more as compared to the split phase motor because of the additional cost of the capacitor. The Capacitor start motor can be reversed by first bringing the motor to rest condition and then reversing the connections of one of the windings.

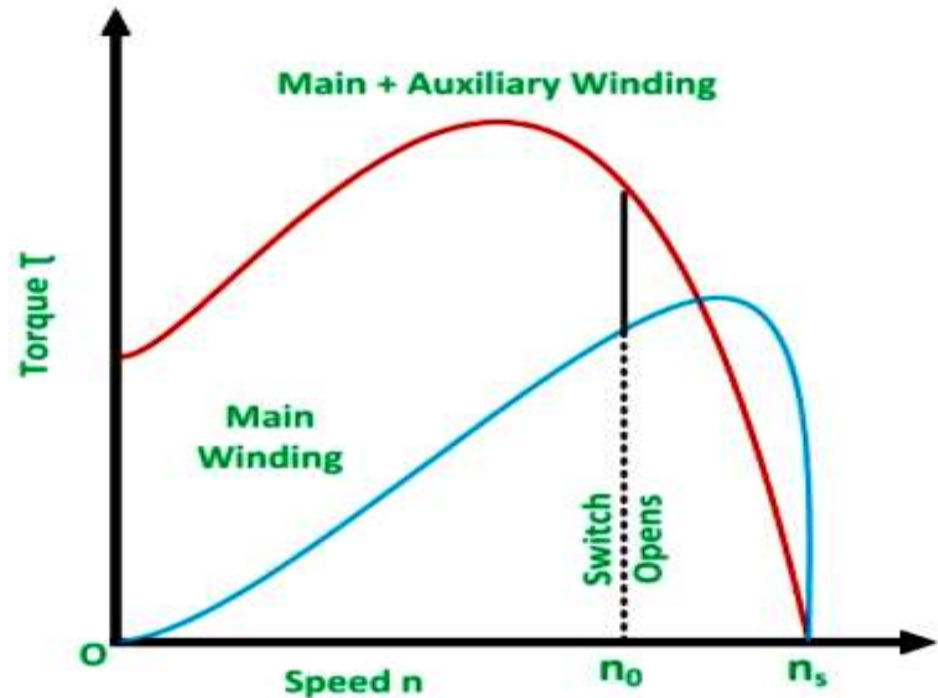

SINGLE PHASE INDUCTION MOTOR

STARTING METHODS OF SINGLE PHASE INDUCTION MOTOR

Capacitor Start Induction Motor

Characteristics of the Capacitor Start Motor

The capacitor starts motor develops a much higher starting torque of about 3 to 4.5 times of the full load torque. To obtain a high starting torque, the two conditions are essential. They are as follows:-

1. The Starting capacitor value must be large.
2. The value of the starting winding resistance must be low.

The electrolytic capacitors of the order of the 250 μF are used because of the high Var rating of the capacitor requirement.



SINGLE PHASE INDUCTION MOTOR

STARTING METHODS OF SINGLE PHASE INDUCTION MOTOR

Capacitor Start Induction Motor

Applications of the Capacitor Start Motor

The various applications of the motor are as follows:

1. These motors are used for the loads of higher inertia where frequent starting is required.
2. Used in pumps and compressors
3. Used in the refrigerator and air conditioner compressors.
4. They are also used for conveyors and machine tools.



SINGLE PHASE INDUCTION MOTOR

STARTING METHODS OF SINGLE PHASE INDUCTION MOTOR

Permanent Split Capacitor (PSC) Motor

The Permanent Split Capacitor motor also has a cage rotor and the two windings named as main and auxiliary windings similar to that of a Capacitor Start and Capacitor Start Capacitor Run Motor. It has only one capacitor connected in series with the starting winding. The capacitor C is permanently connected in the circuit both at the starting and the running conditions.

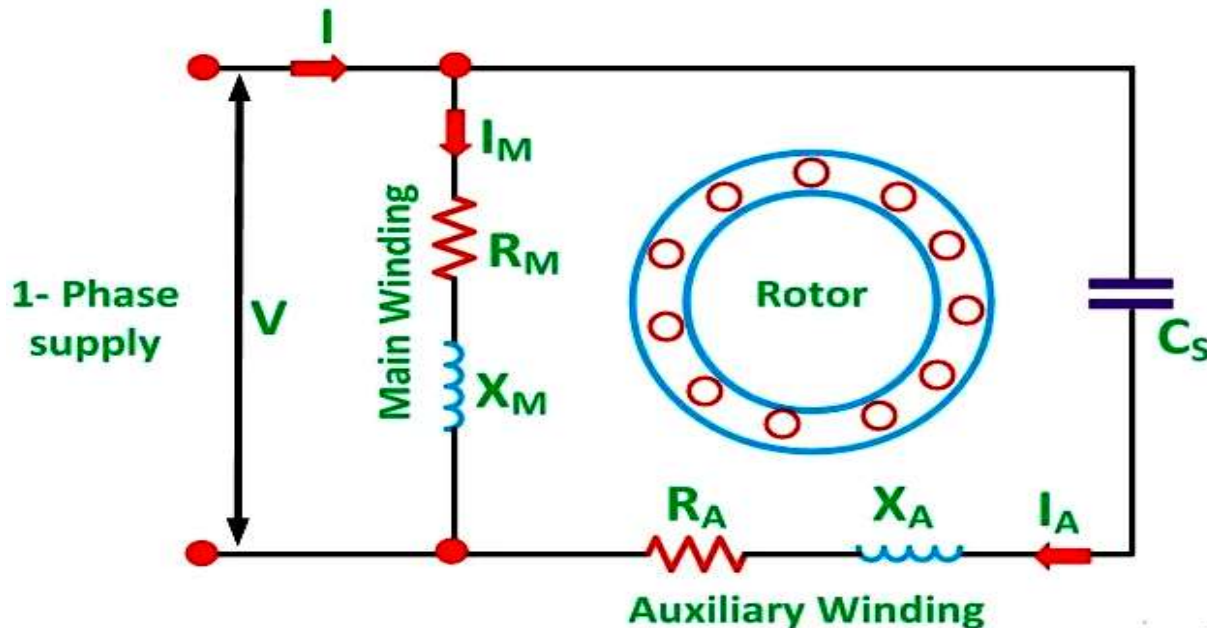

SINGLE PHASE INDUCTION MOTOR

STARTING METHODS OF SINGLE PHASE INDUCTION MOTOR

Permanent Split Capacitor (PSC) Motor

It is also called as a Single Value Capacitor Motor. As the capacitor is always in the circuit and thus this type of motor does not contain any starting switch. The auxiliary winding is always there in the circuit. Therefore, the motor operates as the balanced two-phase motor. The motor produces a uniform torque and has noise free operation.

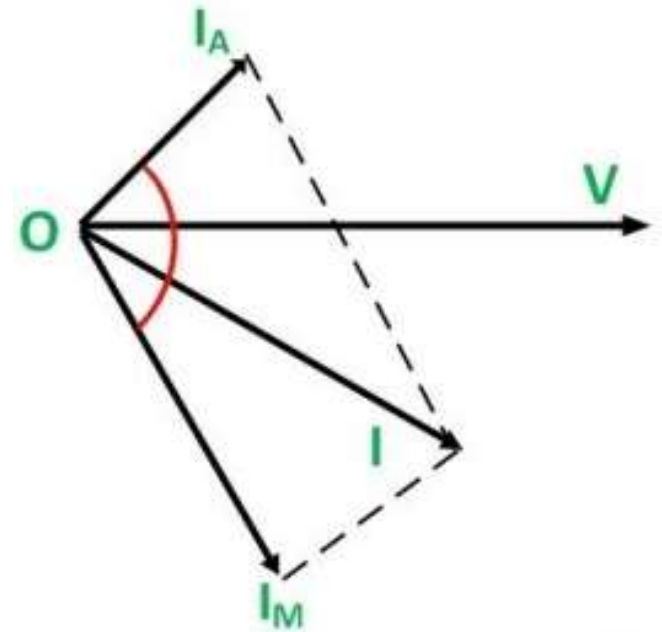
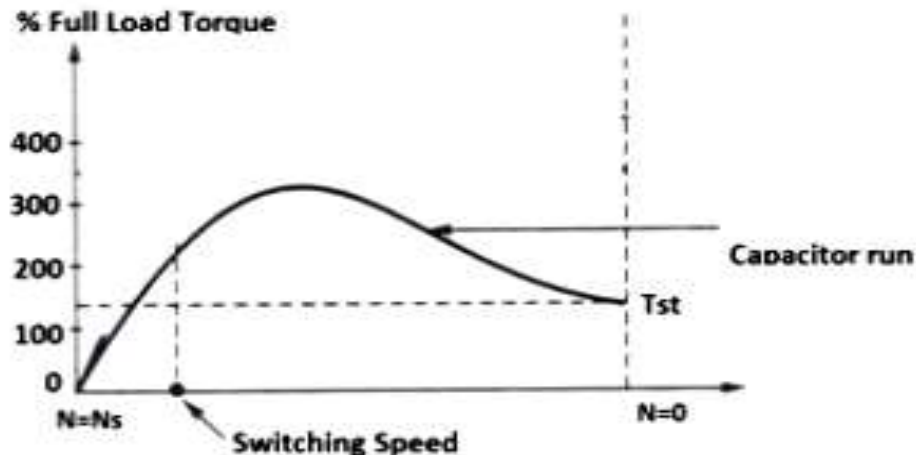

SINGLE PHASE INDUCTION MOTOR

STARTING METHODS OF SINGLE PHASE INDUCTION MOTOR

Permanent Split Capacitor (PSC) Motor

Advantages of Permanent Split Capacitor Motor

The Single Value Capacitor Motor has following advantages.

1. No centrifugal switch is required.
2. Efficiency is high.
3. As the capacitor is connected permanently in the circuit, the power factor is high.
4. It has a higher pullout torque.

Limitations of Permanent Split Capacitor Motor

The limitations of the motor are as follows:-

1. The paper capacitor is used in the motor as an Electrolytic capacitor cannot be used for continuous running. The cost of the paper capacitor is higher, and size is also large as compared to the electrolytic capacitor of the same ratings.
2. It has low starting torque, less than full load torque.



SINGLE PHASE INDUCTION MOTOR

STARTING METHODS OF SINGLE PHASE INDUCTION MOTOR

Permanent Split Capacitor (PSC) Motor

Applications of Permanent Split Capacitor Motor

The various applications of the split motor are as follows:

1. Used in fans and blowers in heaters and air conditioners.
2. Used in refrigerator compressors.
3. Used in office machinery.



Name of the course : Electrical Machines – II

Course Code : EE 501

Semester : 5th

**Lecture:
01**

SL.NO.	TOPIC	LECTURE NO.
1.	Construction, Concept of Pulsating Torque, Double-revolving field theory.	2
2.	Development of equivalent circuit, Determination of equivalent circuit parameters, Solution of problems.	2
3.	Methods of starting using auxiliary winding, Selection of capacitor value during starting and running, Solution of problems.	2
4.	Speed-Torque characteristics, Phasor diagram, Condition of Maximum torque.	2
5.	Constructional features and performance characteristics of Universal Series Motors, Compensated and uncompensated motors.	2
6.	Testing of Single phase motors and Applications.	1

TOPIC:

**□ INTRODUCTION TO SINGLE PHASE
INDUCTION MOTOR**

**□ CONSTRUCTION OF SINGLE PHASE
INDUCTION MOTOR**

**Lecture:
01**

SINGLE PHASE INDUCTION MOTOR

INTRODUCTION

As the power requirements of single load systems are usually small, all our homes, offices are supplied with a single-phase A.C. supply only. To get proper working conditions using this single-phase supply, compatible motors have to be used. Besides being compatible, the motors have to be economical, reliable and easy to repair. One can find all of these characteristics in a single phase induction motor readily. Single-phase induction motors are a great choice for domestic appliances. Their simple design and low cost have attracted many applications.

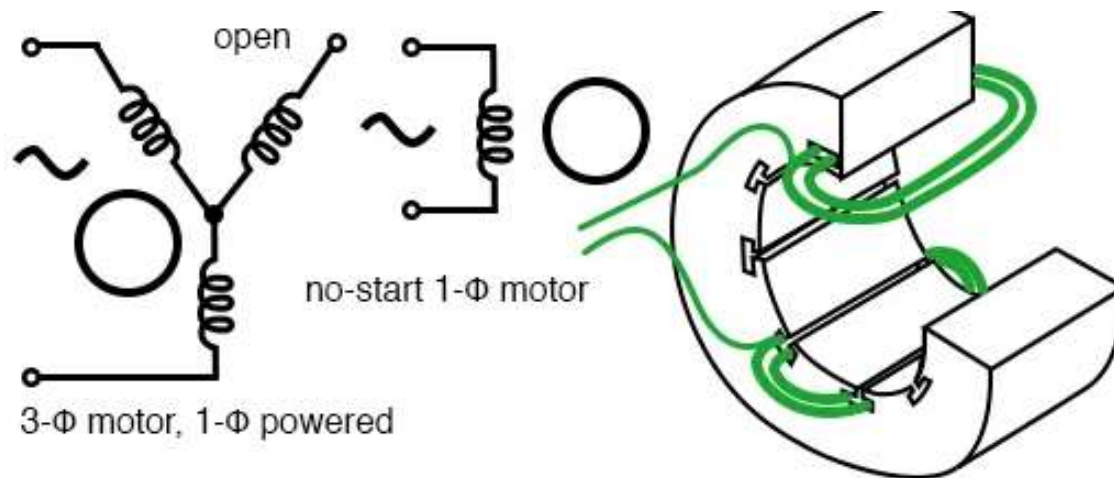

Single-phase induction motors are the simple motors which operate on single -phase A.C. and in which torque is produced due to induction of electricity caused by the alternating magnetic fields. Single phase induction motors are of different types based on their starting conditions and various factors.



SINGLE PHASE INDUCTION MOTOR

INTRODUCTION

We use the single-phase power system more widely than three phase system for domestic purposes, commercial purposes and some extent in industrial uses. Because, the single-phase system is more economical than a three-phase system and the power requirement in most of the houses, shops, offices are small, which can be easily met by a single phase system.

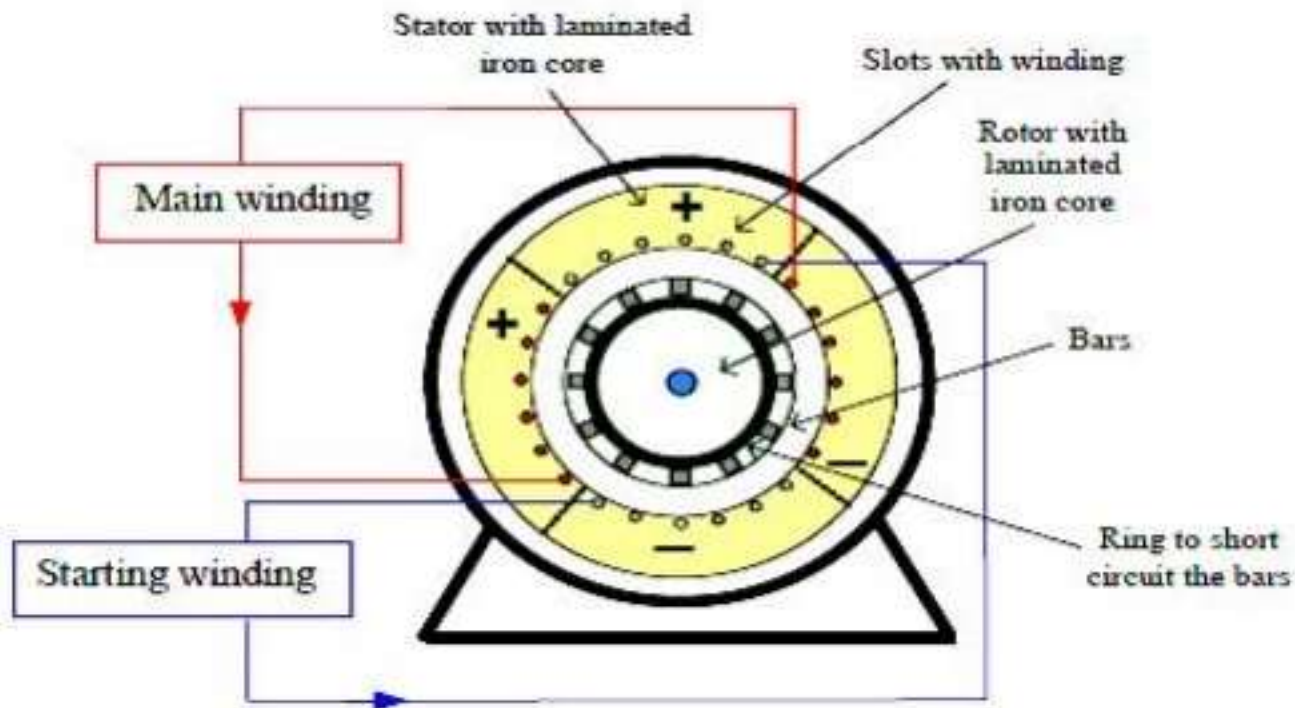

The single phase motors are simple in construction, cheap in cost, reliable and easy to repair and maintain. Due to all these advantages, the single phase motor finds its application in vacuum cleaners, fans, washing machines, centrifugal pumps, blowers, washing machines, etc.



SINGLE PHASE INDUCTION MOTOR

INTRODUCTION

There are two basic reasons for the use of single-phase motors rather than 3-phase motors.

1. For reason of economy, most houses, offices and also rural areas are supplied with single phase A.C, as power requirements of individual load items are rather small.
1. The economics of the motor and its branch circuit.
 - Fixed loads requiring not more than 0.5KW can generally be served most economically with single phase power and a single phase motor.
 - Single phase motors are simple in construction, reliable, easy to repair and comparatively cheaper in cost and therefore, find wide use in fans, refrigerators, vacuum cleaners, washing machines, other kitchen equipment, tools, blowers, centrifugal pumps, small farming appliances etc.

Because of above reasons motors of comparatively small ratings (mostly in fractional KW ratings) are manufactured in large number to operate on single phase ac at standard frequencies. An indication of the number of such motors can be had from the fact that the sum of total of all fractional kilowatt motors in use today far exceeds the total of integral kilowatt motors of all types.



SINGLE PHASE INDUCTION MOTOR

TYPES OF SINGLE-PHASE MOTOR

The Single phase motors may be of the following types:

1. Single-phase Induction Motors:

A. Split-phase motors

(i) Resistance-start motor

(ii) Capacitor-start motor

(iii) Permanent-split (single-value) capacitor motor

(iv) Two-value capacitor motor.

B. Shaded-pole induction motor.

C. Reluctance-start induction motor.

D. Repulsion-start induction motor.

2. Commutator-Type, Single-Phase Motors:

A. Repulsion motor.

B. Repulsion-induction motor.

C. A.C series motor.

D. Universal motor.

3. Single-phase Synchronous Motors:

A. Reluctance motor.

B. Hysteresis motor.

C. Sub-synchronous motor



SINGLE PHASE INDUCTION MOTOR

CONSTRUCTION OF SINGLE PHASE INDUCTION MOTOR

A single phase induction motor is similar to the three phase squirrel cage induction motor except there is single phase two windings (instead of one three phase winding in 3-phase motors) mounted on the stator and the cage winding rotor is placed inside the stator which freely rotates with the help of mounted bearings on the motor shaft.

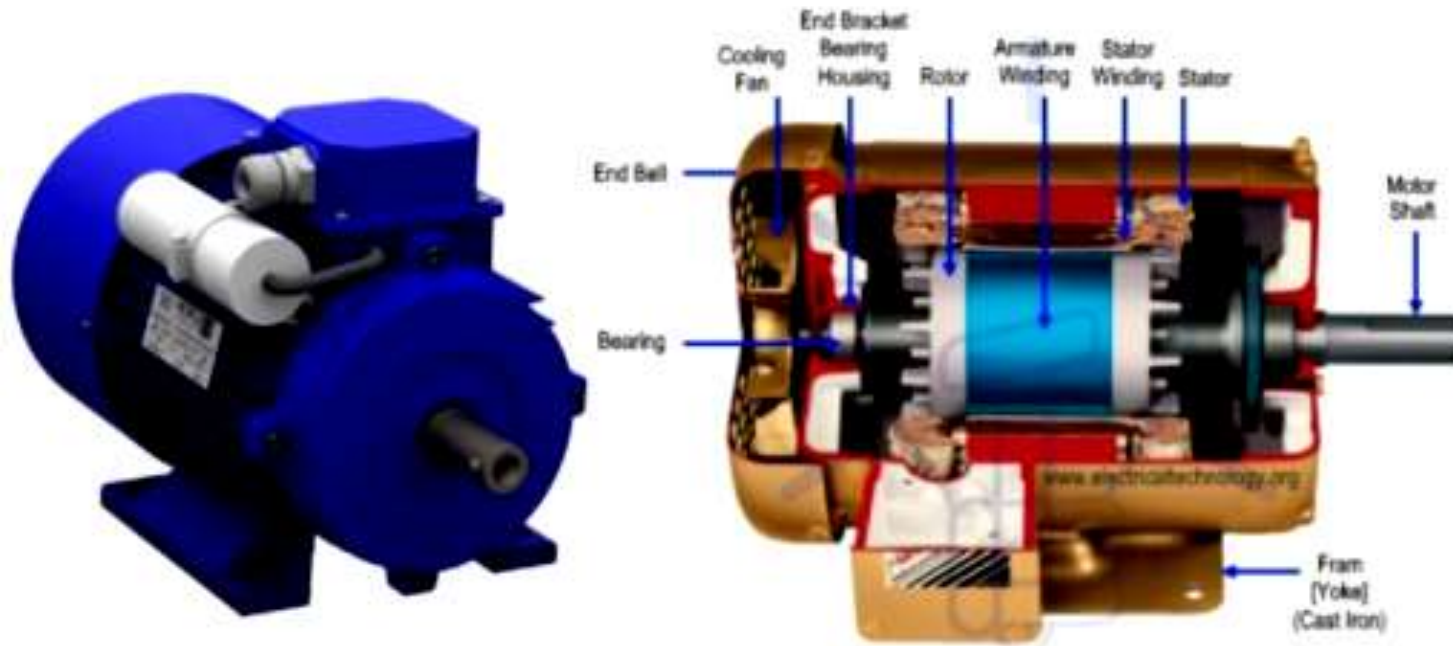

SINGLE PHASE INDUCTION MOTOR

CONSTRUCTION OF SINGLE PHASE INDUCTION MOTOR

Similar to a three-phase induction motor, single-phase induction motor also has two main parts;

1. Stator

2. Rotor

1. Stator

In stator, the only difference is in the stator winding. The stator winding is single-phase winding instead of three-phase winding. The stator core is the same as the core of the three-phase induction motor.

In a single-phase induction motor, there are two windings are used in stator except in shaded-pole induction motor. Out of these two windings, one winding is the main winding and the second is auxiliary winding.

The stator core is laminated to reduce the eddy current loss. The single-phase supply is given to the stator winding (main winding)

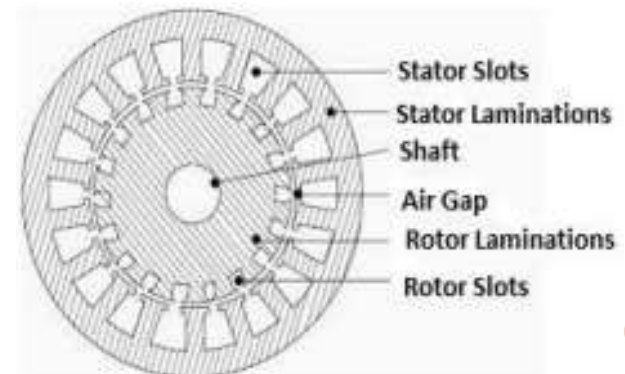

SINGLE PHASE INDUCTION MOTOR

CONSTRUCTION OF SINGLE PHASE INDUCTION MOTOR

The construction of the rotor of the single phase induction motor is similar to the squirrel cage three phase inductions motor. The rotor is cylindrical in shape and has slots all over its periphery. The slots are not made parallel to each other but are bit skewed as the skewing prevents magnetic locking of stator and rotor teeth and makes the working of induction motor more smooth and quieter. The squirrel cage rotor consists of aluminum, brass or copper bars. These aluminum or copper bars are called rotor conductors and are placed in the slots on the periphery of the rotor.



SINGLE PHASE INDUCTION MOTOR

CONSTRUCTION OF SINGLE PHASE INDUCTION MOTOR

The rotor conductors are permanently shorted by the copper or aluminum rings called the end rings. In order to provide mechanical strength these rotor conductor are braced to the end ring and hence form a complete closed circuit resembling like a cage and hence got its name as "squirrel cage induction motor". As the bars are permanently shorted by end rings, the rotor electrical resistance is very small and it is not possible to add external resistance as the bars are permanently shorted. The absence of slip ring and brushes make the construction of single phase induction motor very simple and robust.

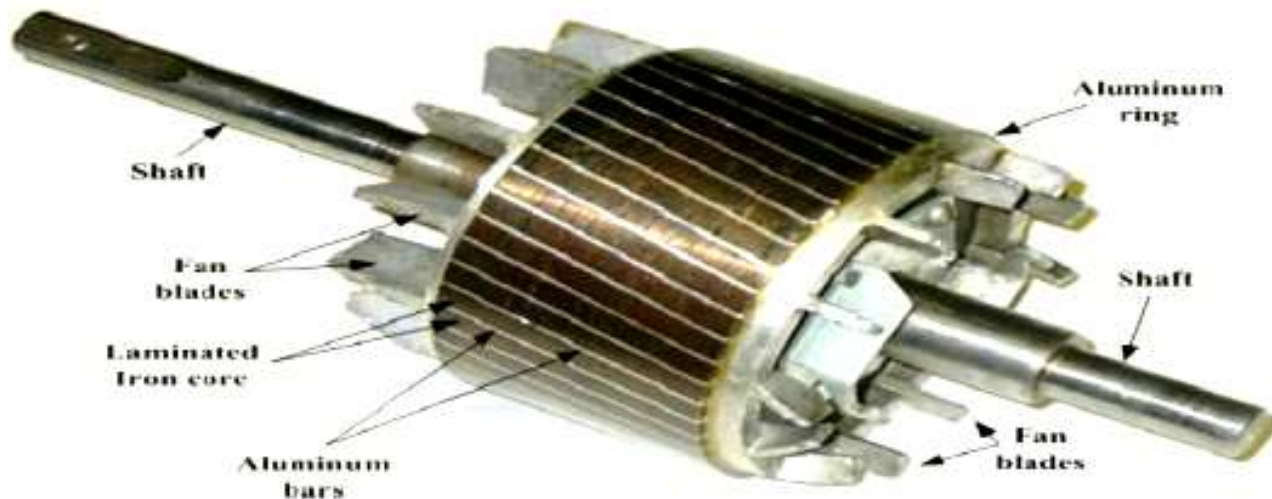

SINGLE PHASE INDUCTION MOTOR

CONSTRUCTION OF SINGLE PHASE INDUCTION MOTOR

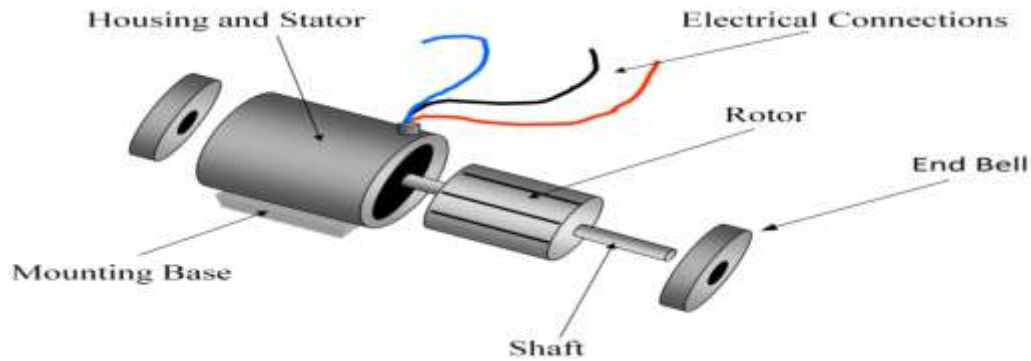

Split-phase motor

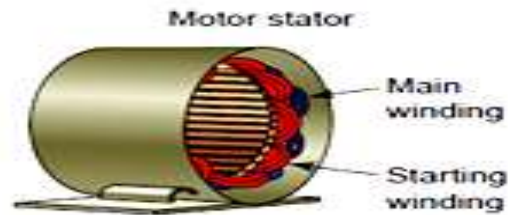

Motor stator

Main winding
Starting winding

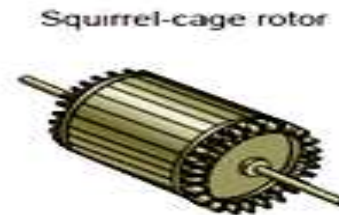

Squirrel-cage rotor

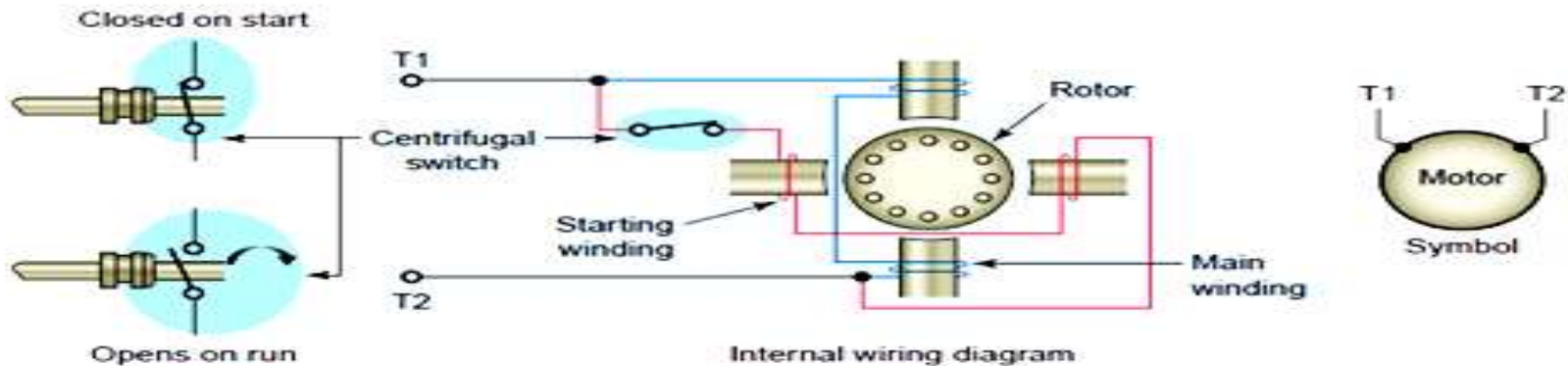

SINGLE PHASE INDUCTION MOTOR

CONSTRUCTION OF SINGLE PHASE INDUCTION MOTOR

Identifying starting and running winding of single phase induction motor

The running winding also called the main winding while the starting winding is better known with name of "auxiliary winding".

If you open the single phase motor , you will find out that your motor have two types of winding in which one is made from thick wire gauge and one thin . the thick wire gauge winding is main winding and thin wire gauge winding is starting winding.

For example is you find out two winding and one winding are made from 21 SWG and 2nd winding is made from 26 Then 21 SWG is greater in size which running winding or main winding and 26 SWG winding is starting or auxiliary winding.

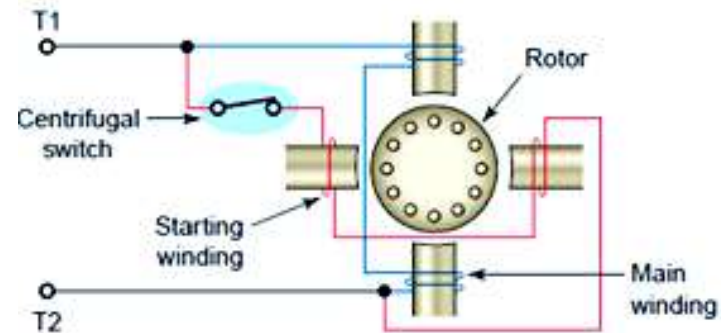
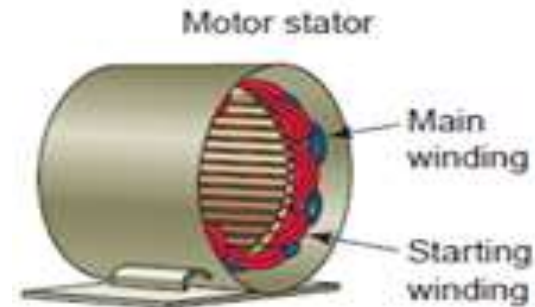
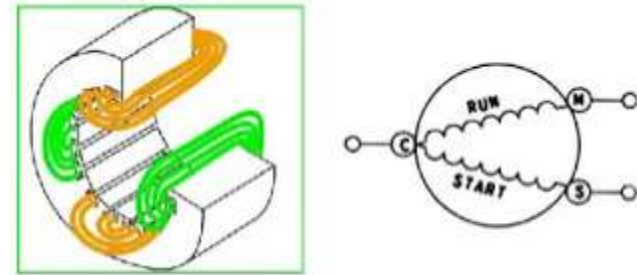

SINGLE PHASE INDUCTION MOTOR

CONSTRUCTION OF SINGLE PHASE INDUCTION MOTOR

Identifying starting and running winding of single phase induction motor

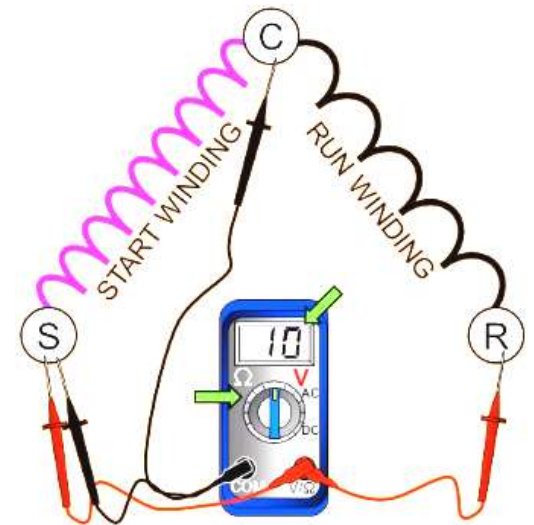
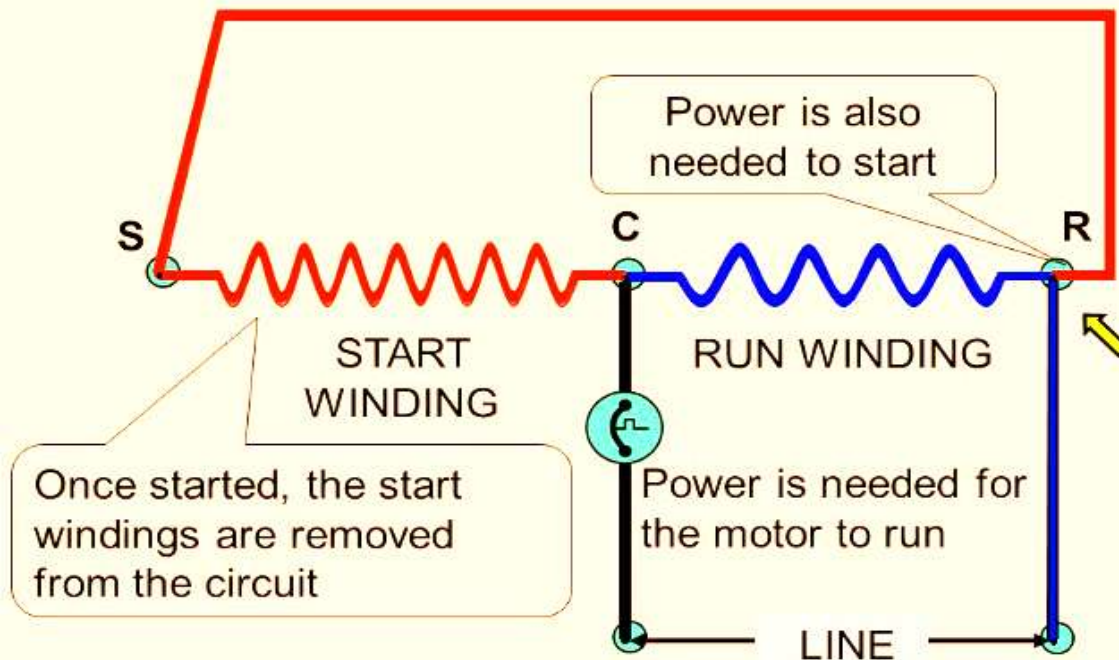

TOPIC:

- ❑ **SWITCHED RELUCTANCE MOTOR**
- ❑ **PERMANENT MAGNET MOTORS**

**Lecture:
21**

SPECIAL MACHINES

SWITCHED RELUCTANCE MOTOR

The Switched Reluctance (SR) motor is very different from the other poly-phase machines described because both the stator and the rotor have salient poles. The motor can only be used in conjunction with its specific power converter and control, and consequently only overall characteristics are relevant.

The SR motor produces torque through the magnetic attraction which occurs between stator electromagnets and a corresponding set of salient poles formed on a simple rotor made only of ferromagnetic material.

The switched reluctance motor (SRM) is a type of motor doubly salient with phase coils mounted around diametrically opposite stator poles. There are no windings or permanent magnets on the rotor. The rotor is basically a piece of (laminated) steel and its shape forms salient poles. The stator has concentrated coils.

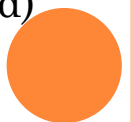
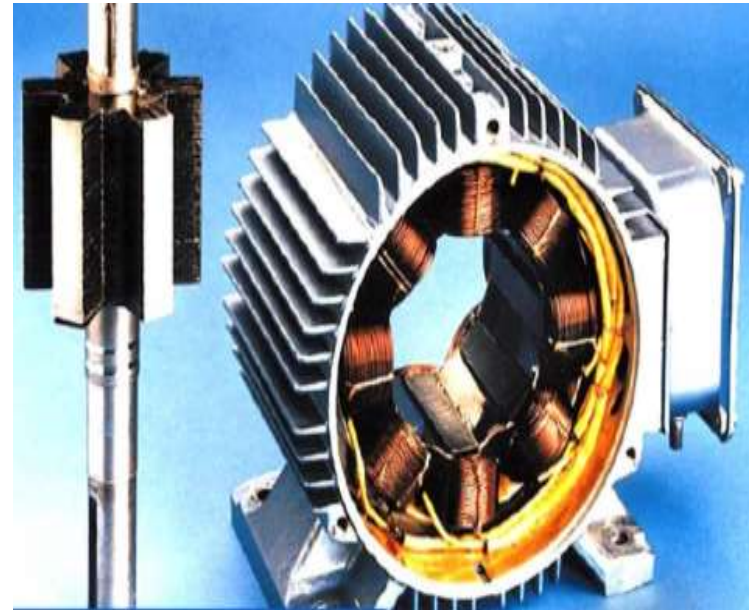

SPECIAL MACHINES

SWITCHED RELUCTANCE MOTOR

Switched reluctance motors (SRM) have a simple and robust structure, thus they are generally suitable for high-speed applications. High-speed motors have the advantage of high power density, which is an important issue of traction motors in electric vehicles (EV). Therefore, high speed SRM seems to be promising candidates for this application.

Switched Reluctance Motor (SRM) is also known as Variable Reluctance Motor. This motor works on the principle of variable reluctance. This means, the rotor always tries to align along the lowest reluctance path. As the name suggests, a switching inverter is required for the operation of Switched Reluctance Motor.

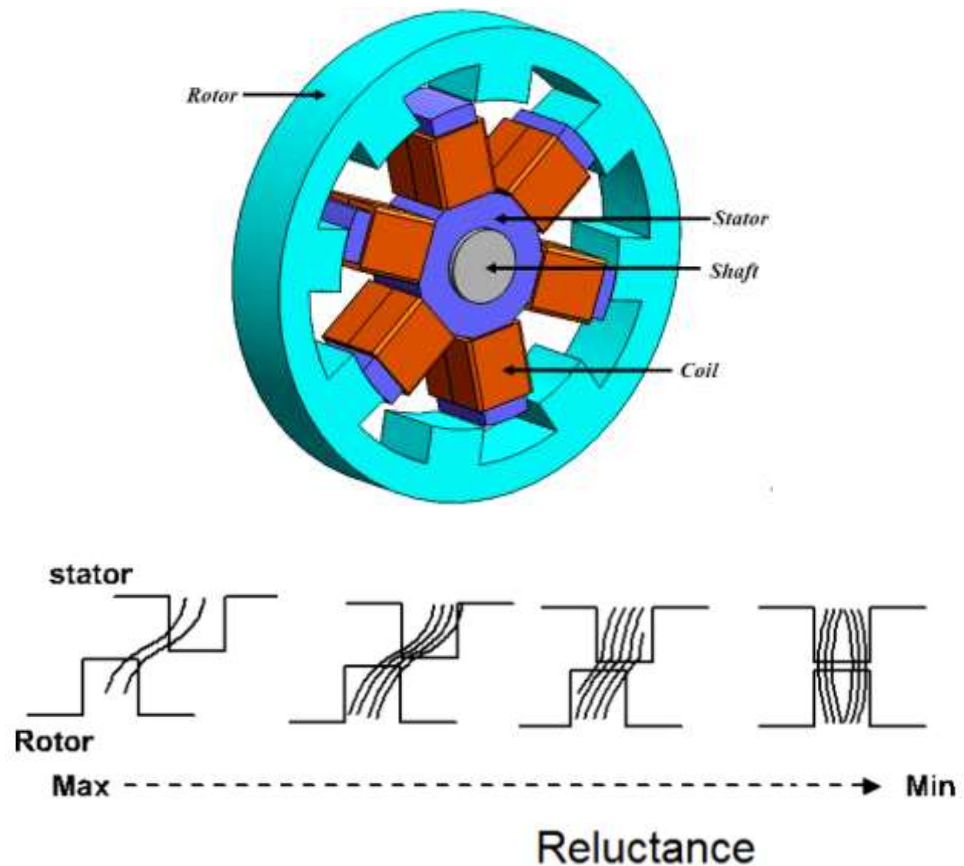

SPECIAL MACHINES

SWITCHED RELUCTANCE MOTOR

Variable Reluctance Motor or Switched Reluctance Motor has two different constructions: Singly Salient Construction and Doubly Salient Construction. Stator and rotor magnetic circuits are laminated to reduce the core losses in both type of SRM.

Singly Salient Construction:

A singly salient construction SRM comprises of a non-salient stator and a salient two pole rotor. The rotor do not have any winding wound over it but the stator have two phase winding. It should be noted that, in actual SRM the number of phase winding on stator may be more than two. Since the rotor is of salient construction, the inductance of stator phase winding varies with the rotor position. The inductance is minimum when the rotor axis and stator phase winding axis coincides whereas it is maximum when both the axis are in Quadrature.

Doubly Salient Construction:

Unlike singly salient type, the stator of doubly salient Switched Reluctance Motor is of salient construction and consists of four poles as shown in figure below. The rotor do not carry any winding and is of salient construction but have two poles. Thus this type of SRM is a heteropolar motor where the numbers of stator and rotor poles are not same.

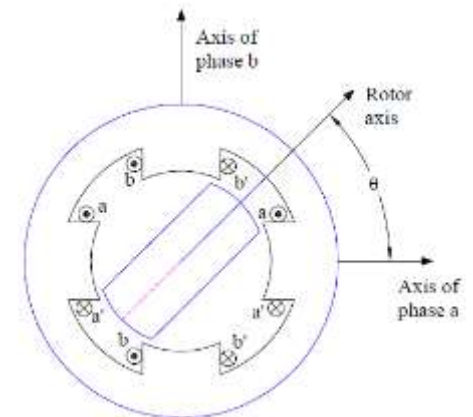
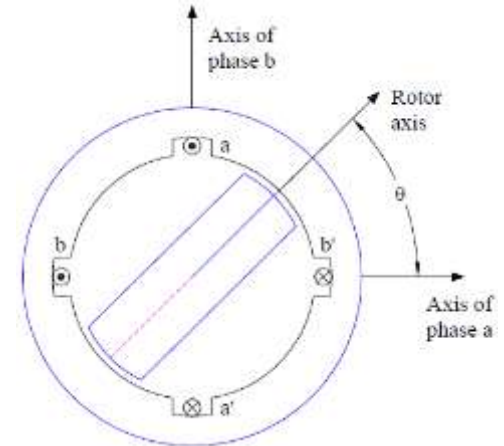

SPECIAL MACHINES

SWITCHED RELUCTANCE MOTOR

TYPES-

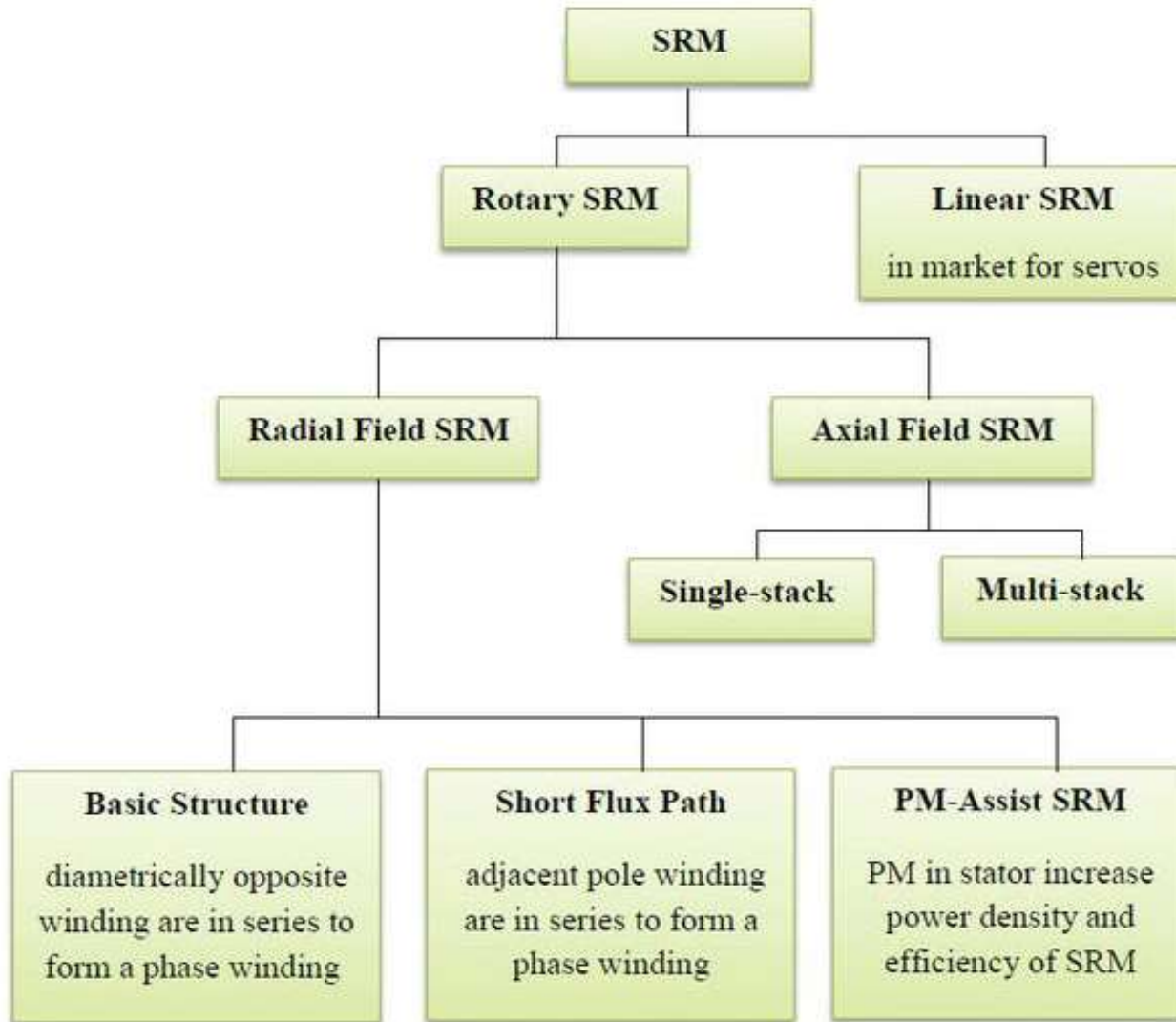

SPECIAL MACHINES

SWITCHED RELUCTANCE MOTOR

APPLICATIONS

Switched Reluctance Motors and Drives can provide an effective alternative to induction motors in many situations where the operating conditions do not suit them. The SRD is well suited to these situations, providing many advantages over the conventional approaches.

Typical applications include:

1. Textile Machinery
2. Oilfield machinery
3. Presses
4. Mining machinery
5. Electric Vehicles



SPECIAL MACHINES

SWITCHED RELUCTANCE MOTOR

APPLICATIONS

6. Miscellaneous Applications

- i. Machine tools: planers, vertical lathes, drilling machines
- ii. General machinery: fans, pumps, compressors
- iii. Food mixing machinery
- iv. Lifting machines: lifts, winches, conveyors
- v. Power generation equipment: wind turbine rotor blade load control
- vi. Plastic manufacturing: extrusion machinery, injection molding machines
- vii. Paper mill machinery
- viii. Metal rolling mill
- ix. Coil winding and unwinding machinery



SPECIAL MACHINES

Permanent Magnet Motors

A permanent magnet (PM) motor is an ac motor that uses magnets imbedded into or attached to the surface of the motor's rotor.

The magnetic field for a synchronous machine may be provided by using permanent magnets made of neodymium-boron-iron, samarium-cobalt, or ferrite on the rotor. In some motors, these magnets are mounted with adhesive on the surface of the rotor core such that the magnetic field is radially directed across the air gap. In other designs, the magnets are inset into the rotor core surface or inserted in slots just below the surface. Another form of permanent-magnet motor has circumferentially directed magnets placed in radial slots that provide magnetic flux to iron poles, which in turn set up a radial field in the air gap.

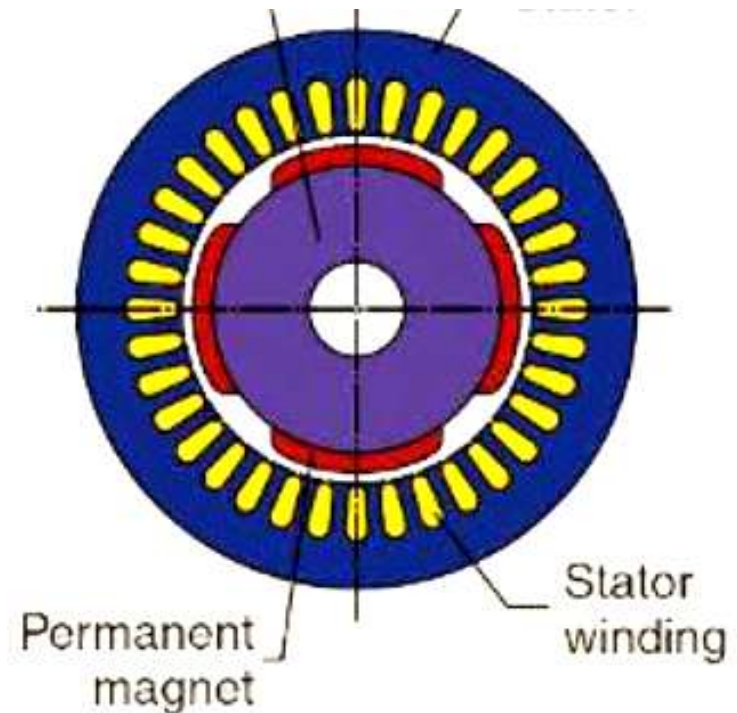

SPECIAL MACHINES

Permanent Magnet Motors

The permanent magnet motor range extends the effective nominal speed range of the rugged industry workhorses down to 100 – 850 r/min. The motors can simplify drive systems by effectively eliminating the need of speed reduction devices. They are designed exclusively for frequency converter supply, where they provide high speed accuracy even without speed sensors because they are synchronous motors without rotor slip.

Features

Torque range 1000 to 50 000 Nm

Construction based on standard induction motor design

Rotor magnetization by permanent magnets

Totally enclosed IP 55 construction

Air- or liquid cooled



TOPIC:

□ BRUSHLESS DC MOTOR

**Lecture:
2**



SYNCHRONOUS MACHINES

Brushless DC motor

A brushless DC motor (known as BLDC) is a permanent magnet synchronous electric motor which is driven by direct current (DC) electricity and it accomplishes electronically controlled commutation system (commutation is the process of producing rotational torque in the motor by changing phase currents through it at appropriate times) instead of a mechanically commutation system. BLDC motors are also referred as trapezoidal permanent magnet motors.

Brushless Direct Current (BLDC) motors are one of the motor types rapidly gaining popularity. BLDC motors are used in industries such as Appliances, Automotive, Aerospace, Consumer, Medical, Industrial Automation Equipment and Instrumentation.

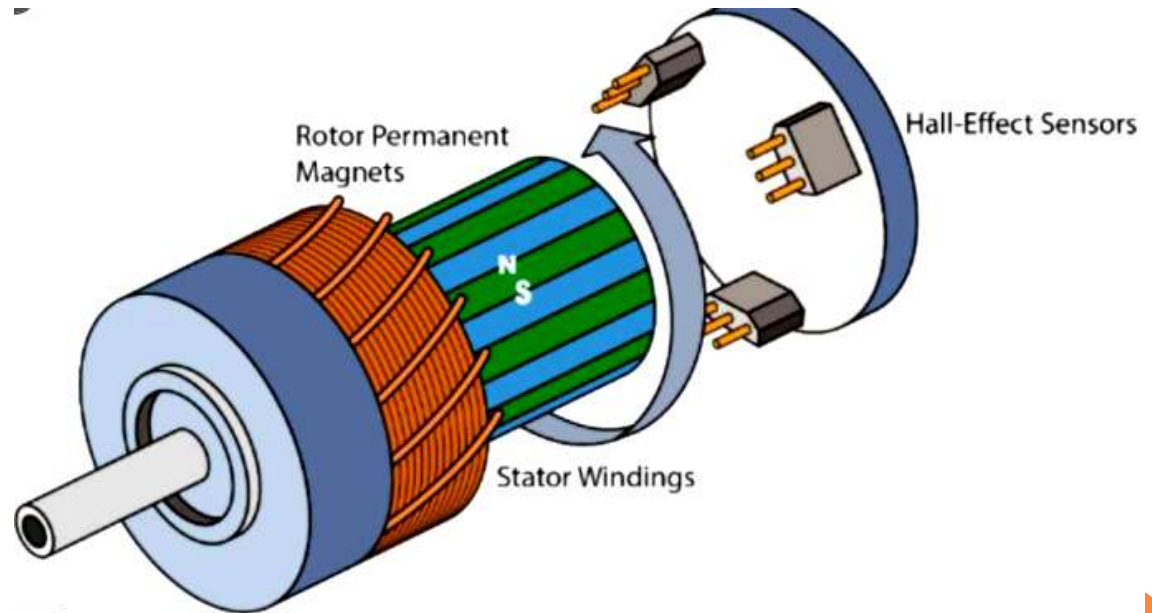

SYNCHRONOUS MACHINES

Brushless DC motor

As the name implies, BLDC motors do not use brushes for commutation; instead, they are electronically commutated.

BLDC motors have many advantages over brushed DC motors and induction motors. A few of these are:

- Better speed versus torque characteristics

- High dynamic response

- High efficiency

- Long operating life

- Noiseless operation

- Higher speed ranges

In addition, the ratio of torque delivered to the size of the motor is higher, making it useful in applications where space and weight are critical factors.



SYNCHRONOUS MACHINES

Brushless DC motor

Unlike conventional brushed type DC motor, wherein the brushes make the mechanical contact with commutator on the rotor so as to form an electric path between a DC electric source and rotor armature windings, BLDC motor employs electrical commutation with permanent magnet rotor and a stator with a sequence of coils. In this motor, permanent magnet (or field poles) rotates and current carrying conductors are fixed.

The armature coils are switched electronically by transistors or silicon controlled rectifiers at the correct rotor position in such a way that armature field is in space Quadrature with the rotor field poles. Hence the force acting on the rotor causes it to rotate. **Hall sensors** or rotary encoders are most commonly used to sense the position of the rotor and are positioned around the stator. The rotor position feedback from the sensor helps to determine when to switch the armature current.

This electronic commutation arrangement eliminates the commutator arrangement and brushes in a DC motor and hence more reliable and less noisy operation is achieved. Due to the absence of brushes BLDC motors are capable to run at high speeds. The efficiency of BLDC motors is typically 85 to 90 percent, whereas as brushed type DC motors are 75 to 80 percent efficient. There are wide varieties of BLDC motors available ranging from small power range to fractional horsepower, integral horsepower and large power ranges.



SYNCHRONOUS MACHINES

Brushless DC motor

CONSTRUCTION AND OPERATING PRINCIPLE

BLDC motors are a type of synchronous motor. This means the magnetic field generated by the stator and the magnetic field generated by the rotor rotate at the same frequency. BLDC motors do not experience the “slip” that is normally seen in induction motors.

BLDC motors come in single-phase, 2-phase and 3-phase configurations. Corresponding to its type, the stator has the same number of windings. Out of these, 3-phase motors are the most popular and widely used. This application note focuses on 3-phase motors.

Stator

The stator of a BLDC motor consists of stacked steel laminations with windings placed in the slots that are axially cut along the inner periphery. Most BLDC motors have three stator windings connected in star fashion. Each of these windings are constructed with numerous coils interconnected to form a winding. One or more coils are placed in the slots and they are interconnected to make a winding. Each of these windings are distributed over the stator periphery to form an even numbers of poles.



SYNCHRONOUS MACHINES

Brushless DC motor

Rotor

The rotor is made of permanent magnet and can vary from two to eight pole pairs with alternate North (N) and South (S) poles.

Based on the required magnetic field density in the rotor, the proper magnetic material is chosen to make the rotor. Ferrite magnets are traditionally used to make permanent magnets. As the technology advances, rare earth alloy magnets are gaining popularity. The ferrite magnets are less expensive but they have the disadvantage of low flux density for a given volume. In contrast, the alloy material has high magnetic density per volume and enables the rotor to compress further for the same torque. Also, these alloy magnets improve the size-to-weight ratio and give higher torque for the same size motor using ferrite magnets.



SYNCHRONOUS MACHINES

Brushless DC motor

Advantages of Brushless DC Motor

The advantages of a BLDC motor are:

1. Brushless motors are more efficient as its velocity is determined by the frequency at which current is supplied, not the voltage.
 2. As brushes are absent, the mechanical energy loss due to friction is less which enhanced efficiency.
 3. BLDC motor can operate at high-speed under any condition.
 4. There is no sparking and much less noise during operation.
 5. More electromagnets could be used on the stator for more precise control.
 6. BLDC motors accelerate and decelerate easily as they are having low rotor inertia.
 7. It is high performance motor that provides large torque per cubic inch over a vast speed range.
 8. BLDC motors do not have brushes which make it more reliable, high life expectancies, and maintenance free operation.
 9. There is no ionizing sparks from the commutator, and electromagnetic interference is also get reduced.
 10. Such motors cooled by conduction and no air flow are required for inside cooling.
- 

SYNCHRONOUS MACHINES

Brushless DC motor

Disadvantages of Brushless DC Motors

1. These motors are costly
2. Electronic controller required control this motor is expensive
3. Not much availability of many integrated electronic control solutions, especially for tiny BLDC motors
4. Requires complex drive circuitry
5. Need of additional sensors



SYNCHRONOUS MACHINES

Brushless DC motor

Applications of Brushless DC Motors (BLDC)

Brushless DC Motors (BLDC) are used for a wide variety of application requirements such as varying loads, constant loads and positioning applications in the fields of industrial control, automotive, aviation, automation systems, health care equipments, etc. Some specific applications of BLDC motors are

1. Computer hard drives and DVD/CD players
2. Electric vehicles, hybrid vehicles, and electric bicycles
3. Industrial robots, CNC machine tools, and simple belt driven systems
4. Washing machines, compressors and dryers
5. Fans, pumps and blowers

