

ELECTRIC DRIVES

(EE701)

Online Courseware (OCW)

B.TECH (4th YEAR – 7th SEM)

(2020-21)

Prepared by: Prof. BARNALI KUNDU

Department of Electrical Engineering



Guru Nanak Institute of Technology

(Affiliated to MAKUT, West Bengal , Approved by AICTE - Accredited by NAAC – ‘A+’ Grade)
157/F Nilgunj road, Panihati, Kolkata-700114, West Bengal

Paper Name: Electrical Drives

Paper Code: EE 701

Contact: 3L:0T:0P

Credit: 3

Prerequisites: Concept of Electrical Machines, and Power Electronics.

Course Outcome: After successful completion of the course students will be able to

CO1: Understand the characteristics of electric motors required for a particular drive.

CO2: Illustrate different types of braking and speed-control of electric motors for various applications.

CO3: Justify power electronic converters for various kinds of drive operations.

Course Content

Module – I: Fundamental Concept of Electric Drive 3L

Definition of electric drive, type of drives; Speed torque characteristic of driven unit/loads, motors, Concept of Multi-quadrant operation, Classification and components of load torque; Equivalent value of drive parameters for loads with rotational and translational motion.

Module – II: Electric Braking 3L

Electric Braking of DC motor during lowering of loads and stopping, Regenerative braking, AC and DC rheostatic braking.

Module – III: Selection of motor power rating 2L

Thermal model of motor for heating and cooling, classes of motor duty, determination of motor rating for continuous, short time and intermittent duty, Load equalization

Module – IV: DC Motor Drives

7L

Ward-Leonard System, Single phase and three phases controlled DC drives, Dual converter control of DC drives. Chopper controlled DC drives, Close loop control of DC drive.

Module – V: Induction Motor Drives

8L

Review of three phase Induction Motor analysis and performance, Stator voltage control, V/f controlled induction motors, Slip power recovery, CSI fed induction motor drives.

Module – VI: Synchronous Motor Drives

10L

Introduction, Sinusoidal SPM machine drives, synchronous reluctance machine drives, wound field synchronous motor drive, Load-commutated Synchronous Motor Drives, Model of PMSM.

Module – VII: Application and Energy conversion Drives 3L

Introduction to Battery Powered Drive for Solar System, Stepper motor Drive, Steel Mills, Paper Mills, Coal Mining, Energy Efficient operation and power factor improvement of drives.

Text Books:

1. G. K. Dubey, "Fundamentals of Electrical Drives", Narosa, 2001.
2. R. Krishnan, "Electric Motor Drives: Modeling, Analysis and Control", PHI-India, 2005.
3. N. K. De and P. K. Sen, "Electric Drives", Prentice Hall of India Private Limited, 2006.
4. S. K. Pillai, "A First Course on Electrical Drives", New Age International.
5. S. B. Dewan, G. R. Slemon and A. Straughen, "Power Semiconductor Drives", John Wiley and Sons, New York 1984.

Reference Books:

1. G. K. Dubey, "Power Semiconductor Controlled Drives", Prentice Hall international, New Jersey, 1989.
2. B. K. Bose, "Modern Power Electronics and AC Drives", Pearson Education Asia, 2003.

CO-PO-PSO Mapping:

COs	POs												PSOs		
	1	2	3	4	5	6	7	8	9	10	11	12	1	2	3
CO.1	3	2	1	2	2	1	2	2	1	2	2	3	2	1	1
CO.2	3	2	2	1	-	2	-	-	2	1	1	-	2	2	1
CO.3	3	3	2	2	2	3	1	2	2	1	2	3	2	2	1
Avg	3	2.3	1.67	1.6	1.3	2	1	1.3	1.6	1.3	1.67	2	2	1.6	1

Module-1: Fundamental Concept of Electric Drive

Introduction to Electrical Drives:

Motion control is required in large number of industrial and domestic applications. Systems employed for getting the required motion and their smooth control are called Drives. Drives require prime movers like Diesel or petrol engines, gas or steam turbines, hydraulic motors or electric motors. These prime movers deliver the required mechanical energy for getting the motion and its control. Drives employing Electric motors as prime movers for motion control are called *Electric Drives*.

Advantages of Electrical Drives:

- The steady state and dynamic performance can be easily shaped to get the desired load characteristics over a wide range of speeds and torques.
- Efficient Starting /Braking is possible with simple control gear.
- With the rapid development in the field of Power Electronics and availability of high speed/high power devices like SCRs, Power MOSFETs, IGBTs etc., design of Efficient Power Converters to feed power to the electric drives has become simple and easy.
- With the rapid development in the computer's HW & SW, PLCs and Microcontrollers which can easily perform the control unit functions have become easily available.
- Electric motors have high efficiency, low losses, and considerable overloading capability. They have longer life, lower noise and lower maintenance requirements.
- They can operate in all the four quadrants of operation in the Torque/Speed plane. The resulting Electric braking capability gives smooth deceleration and hence gives longer life for the equipment. Similarly Regenerative braking results in considerable energy saving.
- They are powered from electrical energy which can be easily transferred,

stored and handled.

Block diagram of an Electrical drive: is shown in the figure below.

Parts of an Electric Drive: The different parts & their functions are explained here.

The load: Can be any one of the systems like pumps, machines etc to carry out a specific task. Usually the load requirements are specified in terms of its speed/torque demands. An electrical motor having the torque speed characteristics compatible to that of the load has to be chosen.

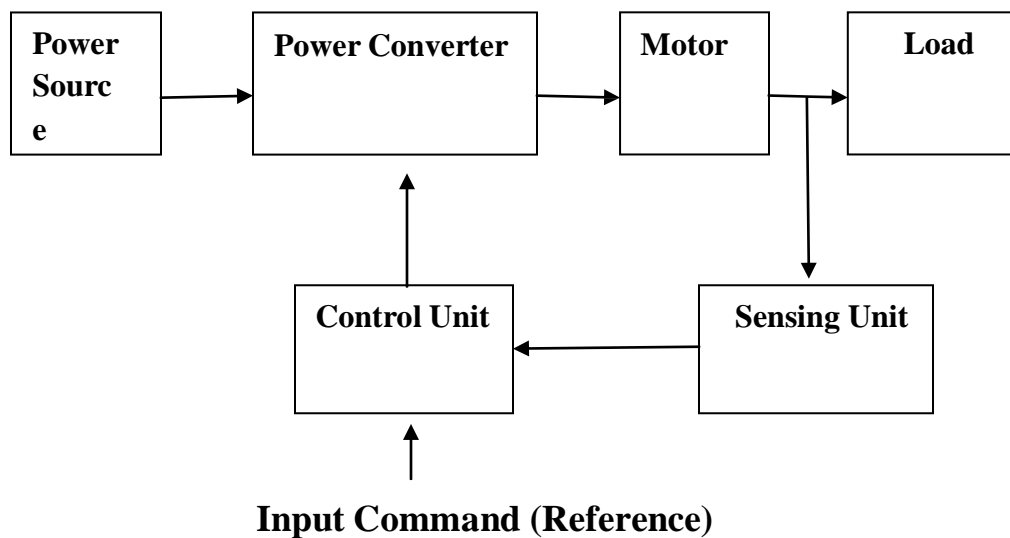

Fig: Block diagram of an Electrical drive

Power Converter: Performs one or more of the following functions.

- Converts Electrical energy from the source into a form suitable to the motor. Say AC to DC for a DC motor and DC to AC for an Induction motor.
- Controls the flow of power to the motor so as to get the Torque Speed characteristics as required by the load.

Module1: Fundamental Concept of Electric Drive

- During transient operations such as Starting, Braking, Speed reversal etc limits the currents to permissible levels to avoid conditions such as Voltage dips, Overloads etc.
- Selects the mode of operation of the Motor i.e Motoring or Braking

Types of Power Converters:

- There are several types of power converters depending upon the type of motor used in a given drive. A brief outline of a few important types is given below.
- AC to DC converters: They convert single phase/Polyphase AC supply into fixed or variable DC supply using either simple rectifier circuits or controlled rectifiers with devices like thyristors, IGBTs, Power MOSFETs etc. depending upon the application.
- AC voltage controllers or AC regulators: They are employed to get a variable AC voltage of the same frequency from a single phase or three phase supply. Some such controllers are Auto transformers, Transformers with various taps and Converters using Power electronics devices.
- DC to DC converters: They are used to get variable DC voltage from a fixed DC voltage source using Power electronics devices. Smooth step less variable voltage can be obtained with such converters.
- Inverters: They are employed to get variable voltage /variable frequency from DC supply using PWM techniques. Inverters also use the same type of Power electronics devices like MOSFETs, IGBTs, SCRs etc.
- Cycloconverters: They convert fixed voltage fixed frequency AC supply into variable voltage variable frequency supply to control AC drives. They are also built using Power electronic devices and by using controllers at lower power level. They are single stage converter devices .

Control unit/Sensing unit: The control unit controls the operation of the Power converter based on the Input command and the feedback signal continuously

Module1: Fundamental Concept of Electric Drive

obtained from a suitable point (In a closed loop operation) at the load end so as to get the desired load performance. The sensor unit gets the feedback on voltage and current also to operate the motor within its safe operating conditions.

Because of the above advantages, in several applications like Diesel locomotives, Ships etc. the mechanical energy already available from a nonelectrical prime mover is first converted into electrical energy by a generator and then An Electric Drive is used as explained above.

Electrical Motors: most commonly used motors are DC motors – Shunt, Series, Compound etc., AC motors- Squirrelcage & Slip ring induction motors, Special motors like Brushless DC motors, stepper motors etc.

DC motors have a number of disadvantages compared to Induction motors due to the presence of commutator and brushes. Squirrel cage motors are less costly than DC motors of the same rating, highly rugged and simple. In the earlier days because of easy speed control DC motors were used in certain applications. But with the development in Power electronics and the advantages of AC motors AC drives have become more popular in several applications in present days.

Concept of Multi-quadrant operation:

For consideration of multi quadrant operation of drives, it is useful to establish suitable conventions about the signs of torque and speed. A motor operates in two modes – Motoring and braking. In motoring, it converts electrical energy into mechanical energy, which supports its motion. In braking it works as a generator converting mechanical energy into electrical energy and thus opposes the motion. Now consider equilibrium point B which is obtained when the same motor drives another load as shown in the figure. A decrease in speed causes the load torque to become greater than the motor torque, electric drive decelerates and operating point moves away from point B. Similarly when working at point B and increase in speed will make motor torque greater than the load torque, which will move the operating point away from point B. Similarly operation in quadrant III and IV can be identified as reverse motoring and reverse braking since speed in these quadrants is negative.

Module1: Fundamental Concept of Electric Drive

For better understanding of the above notations, let us consider operation of hoist in four quadrants as shown in the figure. Direction of motor and load torques and direction of speed are marked by arrows. The figure below represents a DC motor attached to an inertial load. Motor can provide motoring and braking operations for both forward and reverse directions. Figure shows the torque and speed co-ordinates for both forward and reverse motions. Power developed by a motor is given by the product of speed and torque. For motoring operations Power developed is positive and for braking operations power developed is negative.

For better understanding of the above notations, let us consider operation of hoist in four quadrants as shown in the figure. Direction of motor and load torques and direction of speed are marked by arrows.

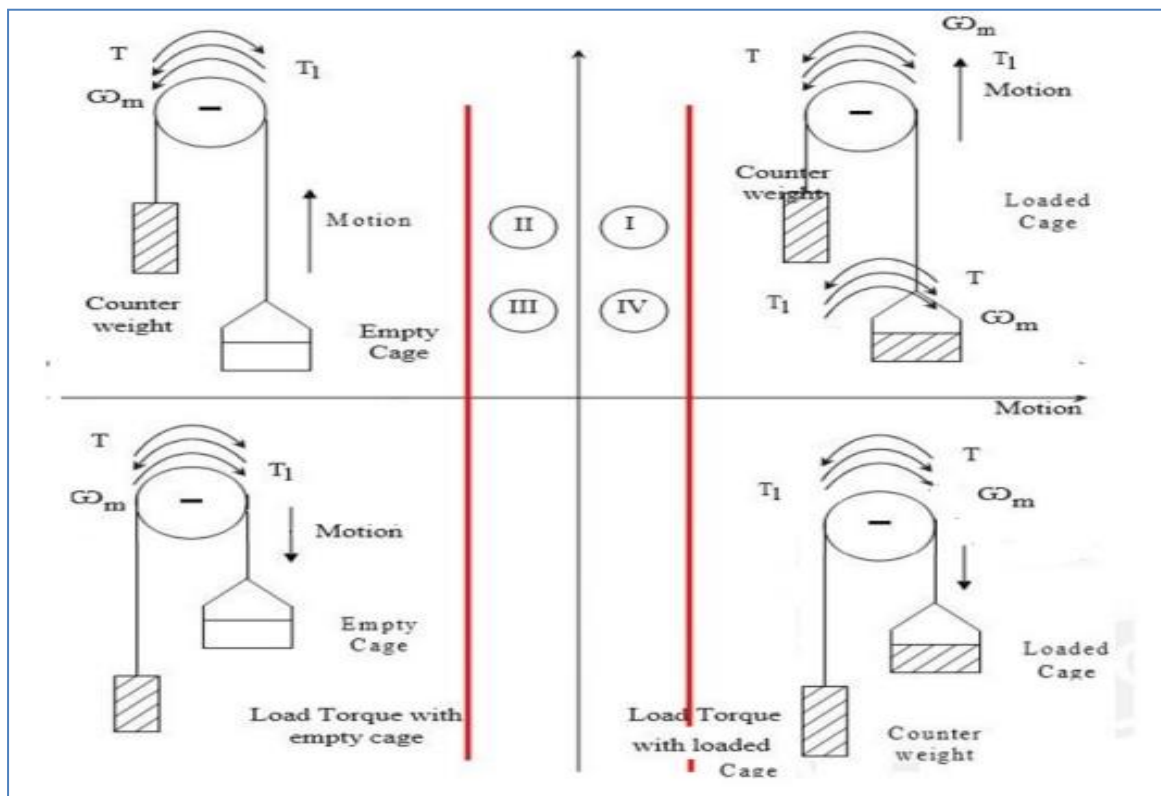

Figure 1: Operation of hoist in four quadrants

(Source: "Fundamentals of Electrical Drives" by G.K.Dubey, page-13)

Module1: Fundamental Concept of Electric Drive

Forward direction of motor speed will be one which gives upward motion of the cage. Load torque line in quadrants I and IV represents speed-torque characteristics of the loaded hoist. This torque is the difference of torques due to loaded hoist and counter weight. The load torque in quadrants II and III is the speed-torque characteristics for an empty hoist.

This torque is the difference of torques due to counter weight and the empty hoist. Its sign is negative because the counter weight is always higher than that of an empty cage. The quadrant I operation of a hoist requires movement of cage upward, which corresponds to the positive motor speed which is in counter clockwise direction here. This motion will be obtained if the motor produces positive torque in CCW direction equal to the magnitude of load torque $TL1$.

Since developed power is positive, this is forward motoring operation. Quadrant IV is obtained when a loaded cage is lowered. Since the weight of the loaded cage is higher than that of the counter weight. It is able to overcome due to gravity itself.

In order to limit the cage within a safe value, motor must produce a positive torque T equal to $TL2$ in anticlockwise direction. As both power and speed are negative, drive is operating in reverse braking operation.

Operation in quadrant II is obtained when an empty cage is moved up. Since a counter weight is heavier than an empty cage, its able to pull it up. In order to limit the speed within a safe value, motor must produce a braking torque equal to $TL2$ in clockwise direction. Since speed is positive and developed power is negative, it's forward braking operation.

Nature of this Components of Load Torques depends on particular application. It may be constant and independent of speed; it may be some function of speed; it may depend on the position or path followed by load; it may be time invariant or time-variant; it may vary cyclically and its nature may also change with the load's mode of operation.

Module1: Fundamental Concept of Electric Drive

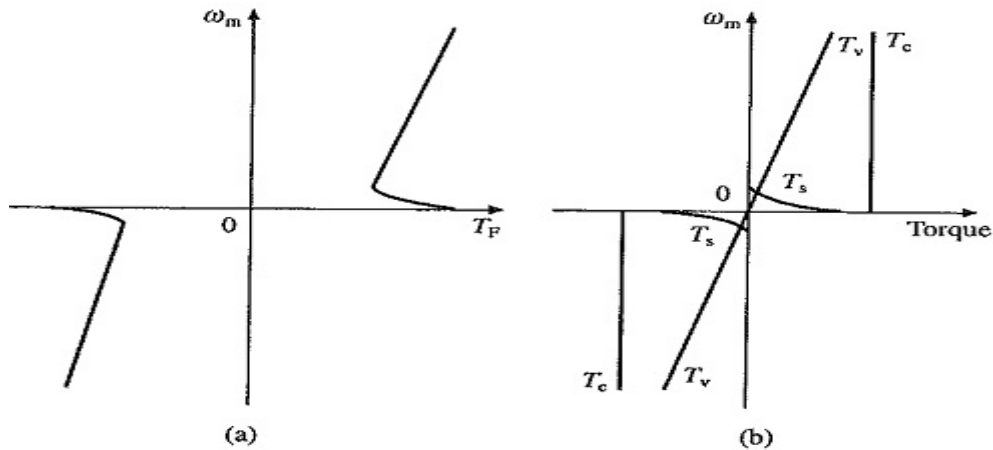

Figure 2: Friction Torque and components

Variation of friction torque with speed is shown in Fig. 2. Its value at standstill is much higher than its value slightly above zero speed. Friction at zero speed is called stiction or static friction. In order for drive to start, the motor torque should at least exceed stiction. Friction torque can be resolved into three components (see Fig. 2b)). Component T_v which varies linearly with speed is called viscous friction and is given by:

$$T = B\omega_m$$

where B is the viscous friction coefficient.

Another component T_c , which is independent of speed, is known as Coulomb friction. Third component T_s accounts for additional torque present at standstill. Since T_s is present only at standstill it is not taken into account in the dynamic analysis.

Windage torque T_w , which is proportional to speed squared, is given by

$$T = C\omega_m^2$$

where C is a constant.

From the above discussion, for finite speeds,

$$T_l = T_L + B\omega_m + T_c + C\omega_m^2$$

In many applications $(T_c + C\omega_m^2)$ is very small compared to $B\omega_m$ and negligible compared to T_L . In order to simplify the analysis, term $(T_c + C\omega_m^2)$ is approximately accounted by updating the value of viscous friction coefficient, B . With this

approximation, from Eq. (2.2)
$$T_l = J \frac{d\omega_m}{dt} + T_L + B\omega_m$$

Module1: Fundamental Concept of Electric Drive

If there is a torsional elasticity in shaft coupling the load to the motor, an additional Component of Load Torques, known as **Coupling Torque**, will be present. Coupling torque (T_e) is given by

$$T_e = k_e \theta_e$$

where θ_e is the torsion angle of coupling (radians) and K_e the rotational stiffness of the shaft (Nm/rad).

Classifications of Various Types of Loads

Most of the industrial loads can be classified into the following two categories :

- (i) Load torques varying with time :
 - Constant continuous type loads: Loads operating continuously for the same loading (same torque) conditions for a long time.
 - Continuous variable loads : Loads varying and having duty cycle.
 - Pulsating loads : Loads of machines with crank shafts.
 - Impact loads : Regular repetitive load peaks such as in rolling mills, forging hammer, etc.
 - Short time loads (e.g. hoists).
- (ii) Load torques varying with speed :
 - Load torques which are independent of speed (e.g. cranes).
 - Load torques proportional to speed (Generator type load) .
 - Load torques proportional to square of the speed (Fan type load).
 - Torque inversely proportional to speed (Constant power type load).

Load Torque-Speed Characteristics

Speed-torque characteristics of the load must be known to calculate the acceleration time and to select the proper type of motor to suit the load. The load speed-torque characteristics of industrial loads are generally non-analytical function $T_L = f(\omega)$. However, some of them may be approximated to an analytic form such as :

I- Constant Torque characteristics: $T_L = k$

Most of the working machines that have mechanical nature of work like shaping, cutting, grinding or shearing, require constant torque irrespective of speed, (See Fig.3(a)). Similarly cranes during the hoisting and conveyors handling constant weight of material per unit time also exhibit this type of characteristics.

2- Torque Proportional to speed: $T_L = k\omega$

Separately-excited d.c. generators connected to a constant resistance load, eddy current brakes have speed-torque characteristics given by $T_L = k\omega$. (See Fig.3(b)).

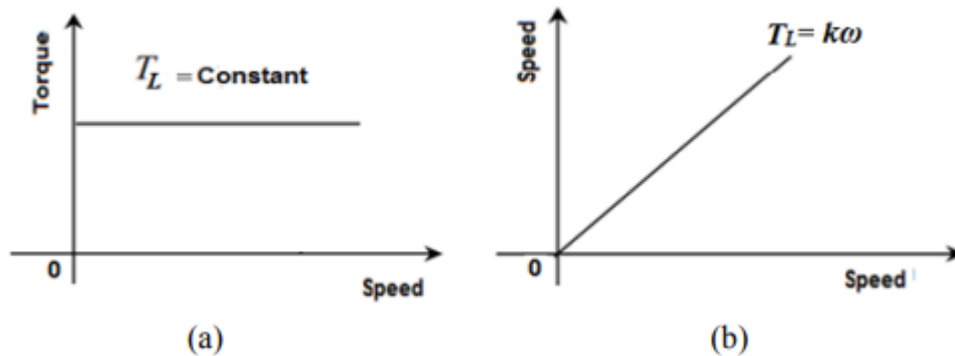

Fig.3 Types of load torque : (a) Constant torque characteristics, (b) Torque proportional to speed.

3- Torque proportional to square of the speed: $T_L = k\omega^2$

Another type of load met in practice is the one in which load torque is proportional to the square of the speed, e.g. : Fans, rotary pumps, compressors and ship propellers. (See Fig.4 (a)).

4. Torque Inversely proportional to speed: $T_L \propto 1/\omega$

Certain types of lathes, boring machines, milling machines, steel mill coiler and electric traction load exhibit hyperbolic speed-torque characteristics as shown in Fig.4(b).

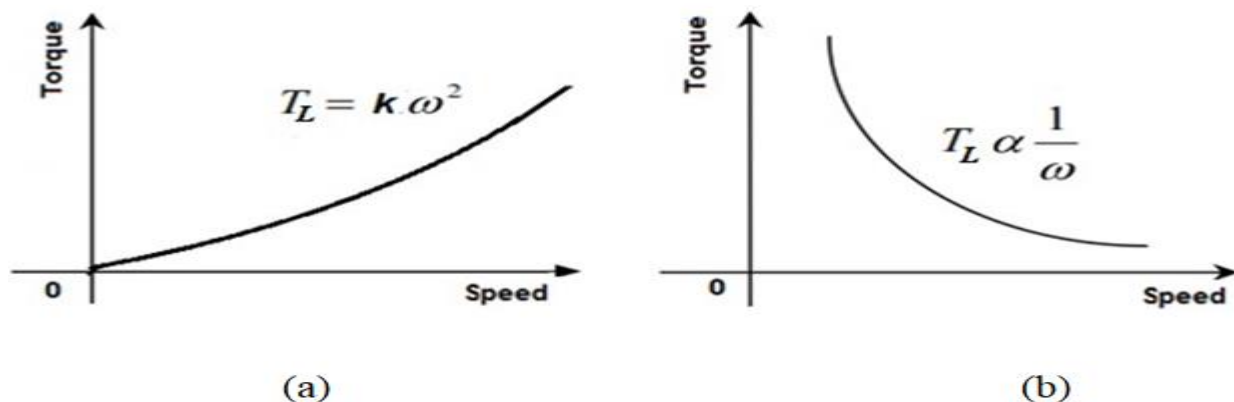

Fig.4 Types of load torque : (a) Torque proportional to square of the speed, (b) Torque inversely proportional to speed .

Dynamic of Motor-Load System:

Fundamental Torque Equations

The dynamic relations applicable to all types of motors and loads. The dynamic or transient condition. These condition appears during starting, braking and speed reversal of the drive.

A motor generally drives a load (machine) through some transmission system. While the motor always rotates, the load may rotate or may undergo a translational motion. It is convenient, however, to represent the motor load system by an equivalent rotational system, as shown in figure .

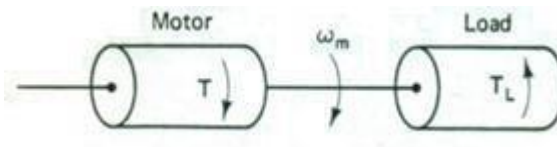

The following notations is adapted:

where :

J = Moment of inertia of motor load system referred to the motor shaft
kg .m².

ω_m = Instantaneous angular velocity of motor shaft, rad /s.

T = Instantaneous value of developed motor torque, Nm.

T_l = Instantaneous value of load torque, referred to the motor shaft, Nm.

Load torque T_l includes *friction* and *windage* torque of motor.

Motor-load system shown in Fig.10.2 can be described by the following fundamental torque equation.

$$T - T_l = \frac{d}{dt}(J\omega_m) = \frac{d\omega_m}{dt} + \omega_m \frac{dJ}{dt} \quad (10.1)$$

Equation (10.1) is applicable to variable inertia drives such as mine winders, reel drives, Industrial robots.

For drives with constant inertia $\frac{dJ}{dt} = 0$

$$T = T_l + \frac{d\omega_m}{dt} \quad (10.2)$$

$J \frac{d\omega_m}{dt}$ = Torque component called dynamic torque because it is present only during the transient operations.

Module1: Fundamental Concept of Electric Drive

$J \frac{d\omega_m}{dt}$ = Torque component called dynamic torque because it is present only during the transient operations.

At steady state operation $J \frac{d\omega_m}{dt} = 0$.

Note: The energy associated with dynamic torque $J \frac{d\omega_m}{dt}$ is stored in the form of kinetic energy given by

$$KE = \frac{1}{2} J \omega^2 \quad (10.3)$$

In the drive systems, depending on the mechanical load, the motor may be subjected to variable operating conditions in its duty cycles. The motor in an electric car can operate in various conditions such as starting, accelerating, steady-state, decelerating and stopping. Fig.10.9 illustrates motor-load torque characteristics, the available starting torque is T_{st} . At this condition, the motor is accelerated and subjected to most severe service. The equation of motion govern the motor in this case is Eq.(10.8).

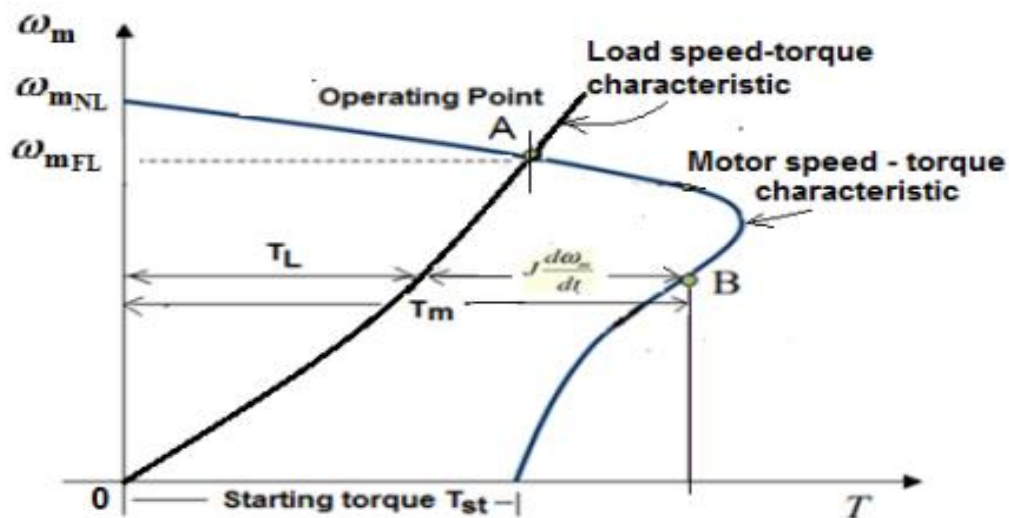

ω_m = Motor speed
 ω_{mNL} = Motor no-load speed
 ω_{mFL} = Motor full-load speed

Example 10.1

A variable speed d.c. drive has rated power of 10 kW, rated speed of 1500 rpm drives a load that comprises a constant load of $T_L = 30$ Nm. The inertia of the drive system is 0.10 kg.m². Calculate the time taken to accelerate the load from zero to 800 rpm, assuming the drive develops rated torque during the acceleration phase.

Solution

$$\text{Rated speed} = 1500 \text{ rpm, in rad/s} = \frac{1500}{60} \times 2\pi = 157 = \omega$$

$$\text{Rated torque} = \frac{P_{\text{rated}}}{\omega} = \frac{10000}{157} = 63.6 \text{ Nm}$$

$$T_a = T_m - T_L = J \frac{d\omega_r}{dt}$$

$$T_a = 63.6 - 30 = 33.6 \text{ Nm}$$

$$T_a = J \frac{\Delta\omega}{\Delta t}$$

$$\Delta t = J \frac{\Delta\omega}{T_a}$$

$$\Delta\omega = (800 \text{ rpm} - 0 \text{ rpm}) \times \frac{2\pi}{60} = 800 \times \frac{2\pi}{60} = 83.73 \text{ rad/s}$$

$$\Delta t = \frac{0.10 \times 83.73}{33.6} = 250 \text{ ms}$$

Example 10.2

An induction motor directly connected to a 400V, 50Hz supply utility has a rated torque of 30Nm that occurs at a speed of 2940 rpm. The motor drives a fan load that can be approximated by: $T_L = B \cdot \omega_m$, where $B = 0.05$ Nm/rad/s, and the rated speed of the motor is 3000 rpm. Stating any assumption made, calculate the speed, in equilibrium position at which the torque developed by the motor is equal to the load torque.

Let ω_{mFl} = speed of the motor at full load.
 ω_{mNl} = speed of the motor at no load.

At full load $T_m = T_{rated} = 30$ Nm

$$\omega_{mFl} = \frac{2940}{60} \times 2\pi = 307.72 \text{ rad/s}$$

At no-load T_m at $\omega_{mNl} = 0$ Nm

$$\omega_{mNl} = \frac{3000}{60} \times 2\pi = 314.15 \text{ rad/s}$$

For the linear region (only)

$$T_m = K (\omega_{mNl} - \omega_m)$$

$$\therefore K = \frac{30}{(314.15 - 307.72)} = 4.66$$

For the load

$$T_L = B\omega_m = 0.05 \omega_m$$

For the equilibrium position

$$4.66 \times (\omega_{mNl} - \omega_m) = 0.05 \omega_m$$

$$4.66 \omega_{mNl} = 4.71 \omega_m$$

$$\omega_m = \frac{4.66 \times 314.15}{4.71} = 310.8 \text{ rad/s} \quad \rightarrow 2967\text{rpm}$$

Load Torque and Load Power

At steady state $T_m = T_L$.

The output power from a motor running at speed ω_m is

$$P_m = T_m \omega_m$$

The power required by the load is

$$P_L = T_L \omega_L$$

If the motor is connected directly to the load as shown in Fig.10.8, then

$$\omega_m = \omega_L$$

Hence $P_m = P_L$

If η is the efficiency of the motor on full load, then

$$T_m = T_L = \frac{\text{Watts Output}}{\eta \omega_m}$$

In some applications, the motor is connected to the load through a set of gears. The gears have a teeth ratio and can be treated as speed or torque transformers. The motor-gear-load connection is shown in Fig.5.

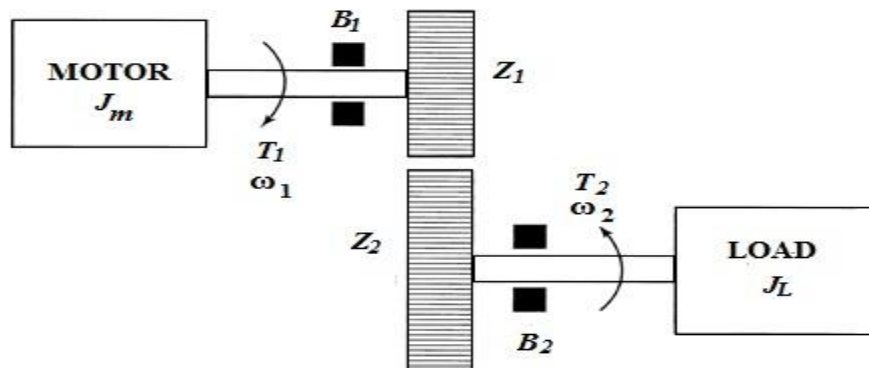

Fig.5 Motor connected to the load through a gear.

[**Module 1: Fundamental Concept of Electric Drive**]

In Fig.5,

Z_1, Z_2 = Teeth number in the gear

B_1, B_2 = Bearings and their coefficients

J_m, J_L = Moment of inertia of the motor and load

The gears can be modelled from the following facts:

(i) The power handled by the gear is the same on both sides.

(ii) Speed on each side is inversely proportional to its tooth number.

Hence

$$T_1 \omega_1 = T_2 \omega_2 \quad (10.12)$$

$$T_2 = \frac{\omega_1}{\omega_2} T_1 \quad (10.13)$$

and

$$\frac{\omega_1}{\omega_2} = \frac{Z_2}{Z_1} = g_r = \text{gears ratio} \quad (10.14)$$

Substituting Eq.(10.14) into Eq.(10.13) yields

$$T_2 = \frac{Z_2}{Z_1} T_1 = g_r T_1 \quad (10.15)$$

At steady-state $T_m = T_L$.

If η is the efficiency of the motor on full load, then

$$T_m = T_L = \frac{\text{Watts input}}{\omega} \times \eta \quad \text{Nm} \quad (10.16)$$

and

$$\text{kW required by the load} = \frac{\text{Watts input}}{1000} \cdot \eta \quad (10.17)$$

Now if the motor is geared to the load, then the torque seen by the load is increased or decreased by the ratio: $\frac{\omega(\text{motor})}{\omega(\text{load})} = \frac{\omega_1}{\omega_2}$.

the translational motion in terms of referred load torque and moment of inertia referred to motor shaft.

Fig.10.12 shows a hoist load lift, wound on drum driven through gears by a motor. If F is the force required due to gravitational pull to lift the moving weight W , η is the efficiency of transmission, v (m/s) is the velocity of the moving mass, and ω_m (rad/s) is the angular velocity of the motor shaft, the referred load torque is obtained by equating the power.

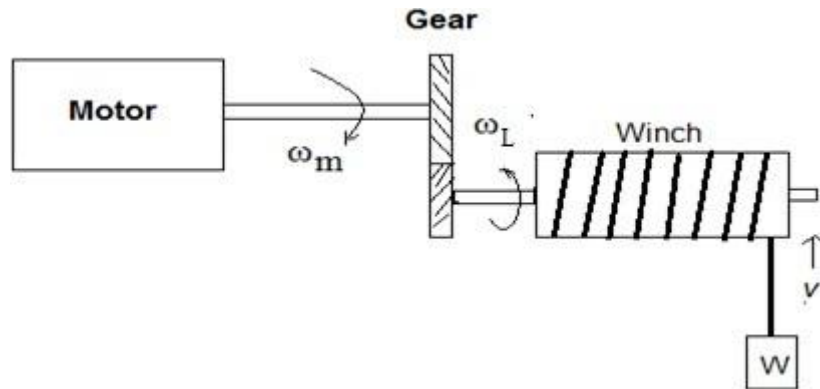

Fig.10.12 Motor-hoist load system.

The referred load torque T'_L :

$$T'_L = \frac{F \cdot v}{\eta \cdot \omega_m} \quad (10.22)$$

The moment of inertia referred to the motor shaft is obtained by equating kinetic energy:

$$\frac{1}{2} m v^2 = \frac{1}{2} J' \omega_m^2$$

$$\text{or } J' = m \left(\frac{v^2}{\omega_m^2} \right) = \frac{W}{g} \left(\frac{v^2}{\omega_m^2} \right) \quad (10.23)$$

where $m = \frac{W}{g}$ kg weight, $g =$ gravitational acceleration = 9.81 .

Example 10.5

A drive used in a hoist to raise and lower weights up to 400 kg at velocities up to ± 2 m/s. The weight hangs from a cable that is wound on

a drum of radius of 0.4 m . The drum is driven by the drive motor through a gearbox that has an efficiency of 85% . The maximum speed of the motor is ± 1300 rpm. It is required to:

- Sketch the system and find the nearest integer gearbox ratio that will match the maximum speed of the motor to the maximum velocity of the hoist.
- Determine the torque and power provided by the motor when lifting the maximum weight at the maximum velocity.
- Calculate the torque and power provided by the motor when lowering the maximum weight at the maximum velocity.

Solution

(a) The system is shown in Fig. 10.13.

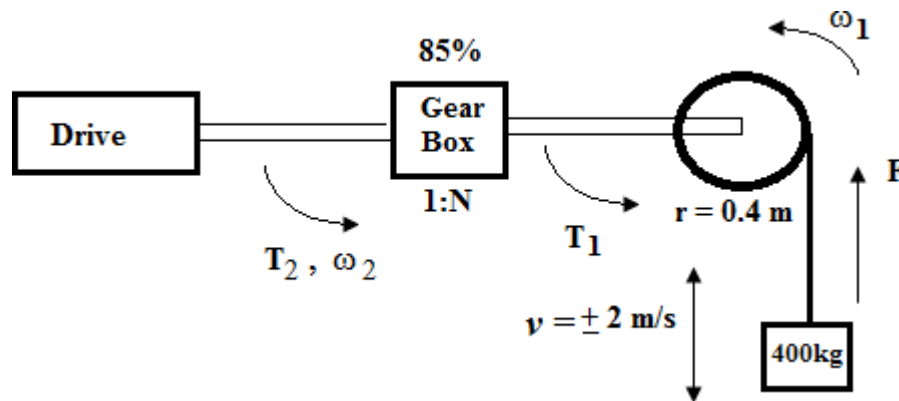

Fig.10.13 System diagram of Example 10.5.

The speed of the weight is given as: $v = 2 \text{ m/s}$

$$\omega_1 = \frac{v}{r} = \frac{2}{0.4} = 5 \text{ rad/s}$$

The motor speed in rad /s is given by

$$\omega_2 = 1300 \times \frac{2\pi}{60} = 136.06 \text{ rad/s}$$

$$N = \frac{\omega_2}{\omega_1} = \frac{136.0}{6} = 22.67 \rightarrow \text{use } 27$$

$$\frac{\omega_2}{27} = 5$$

$$\therefore \omega_2 = 135 \text{ rad/s} \quad \frac{135 \times 60}{2\pi} = 1290 \text{ rpm}$$

(b) Now, when lifting and lowering F is upwards, T_1 is in the direction shown (here anticlockwise)

$$T_1 = \text{Force} \times \text{radius} = 400 \times 9.81 \times 0.4 = 1569.6 \text{ Nm}$$

(Since Force = mass \times gravity)

When lifting, motor drive supplies the losses in the gearbox :

$$T_2 = \frac{T_1}{N.5} = \frac{1569.6}{27 \times 0.85} = 68.4 \text{ Nm}$$

$$T_2 \times \omega_2 \times 5 = T_1 \times \omega_1$$

$$P_{drive} = T_2 \times \omega_2 = 68.4 \times 135 = 9.234 \text{ kW}$$

**DETERMINATION OF MOTOR RATING FOR
CONTINUOUS, SHORT TIME AND
INTERMITTENT DUTY THROUGH,
EQUIVALENT CURRENT METHODS**

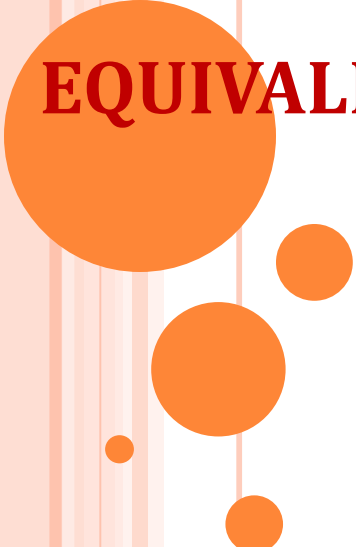

OBJECTIVES OF SELECTION OF MOTOR

POWER RATING

For loads which operate at a constant power and speed, determination of motor power rating is simple and straightforward. But only a few loads operate at a constant speed and power. Most loads operate at variable power and speed, and the patterns of these variations are different for different applications.

This Selection of Motor Power Rating has three objectives:

- ✓ To obtain a suitable thermal model for the machine which can be utilized in calculation of motor ratings for various **Classes of Motor Duty**.
- ✓ Categorization of load variation with time into certain standard categories which are termed as **Classes of Duty** of motor.



Classes of Motor Duty in Electrical Drives

1. **Continuous Duty** : It denotes the motor operation at a constant load torque for a duration long enough for the motor temperature to reach steady-state value. This duty is characterized by a constant motor loss. **Paper mill drives, compressors, conveyers, centrifugal pumps and fans are some examples of Classes of Motor Duty in Electrical Drives. Fig (a)**

2. **Short Time Duty** : In this, time of drive operation is considerably less than the heating time constant and machine is allowed to cool off to ambient temperature before the motor is required to operate again. In this operation, the machine can be overloaded until temperature at the end of loading time reaches the permissible limit. **Some examples are: crane drives, drives for household appliances, turning bridges, sluice-gate drives, valve drives, and many machine tool drives for position control. Fig (b)**



3. Intermittent Periodic Duty : It consists of periodic duty cycles consisting of a period of running at a constant load and a rest period. Neither the duration of running period is sufficient to raise the temperature to a steady-state value, nor the rest period is long enough for the machine to cool off to ambient temperature. In this Classes of Motor Duty in Electrical Drives, heating of machine during starting and braking operations is negligible. **Some examples are pressing, cutting and drilling machine drives. Fig (c)**

4. Intermittent Period Duty with Starting: This is intermittent periodic duty where heat losses during starting cannot be ignored. Thus, it consists of a period of starting, a period of operation at a constant load and a rest period; with operating and rest periods, being too short for the respective steady-state temperatures to be attained. In this duty, heating of machine during braking is considered to be negligible, because mechanical brakes are used for stopping or motor is allowed to stop due to its own friction. **Few examples are metal cutting and drilling tool drives, drives for fork lift trucks, mine hoist etc. Fig (d)**

5. Intermittent Periodic duty with Starting and Braking : This is the intermittent periodic duty where heat losses during starting and braking cannot be ignored. Thus, it consists of a period of starting, a period of operation with a constant load, a braking period with electrical braking and a rest period; with operating and rest periods being too short for the respective steady state temperatures to be attained. **Billet mill drive, manipulator drive, ingot buggy drive, screw down mechanism of blooming mill, several machine tool drives, drives for electric suburban trains and mine hoist are some examples of this duty.** Fig (e)

6. Continuous Duty with Intermittent Periodic Loading : It consists of periodic duty cycles, each consisting of a period of running at a constant load and a period of running at no load, with normal voltage across the excitation winding. Again the load period and no load period being too short for the respective temperatures to be attained. **This Class of Motor Duty in Electrical Drives is distinguished from the intermittent periodic duty by the fact that a period of running at a constant load is followed by a period of running at no load instead of rest. Pressing, cutting, shearing and drilling machine drives are the examples.**

7. Continuous Duty with Starting and Braking: Consists of periodic duty cycle, each having a period of starting, a period of running at a constant load and a period of electrical braking; there is no period of rest. **The main drive of a blooming mill is an example.**
8. Continuous Duty with Periodic Speed Changes : Consists of periodic duty cycle, each having a period of running at one load and speed, and another period of running at different speed and load; again both operating periods are too short for respective steady-state temperatures to be attained. Further there is no period of rest



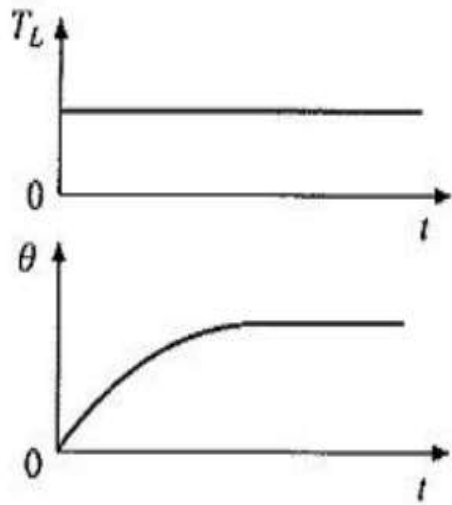

(a)

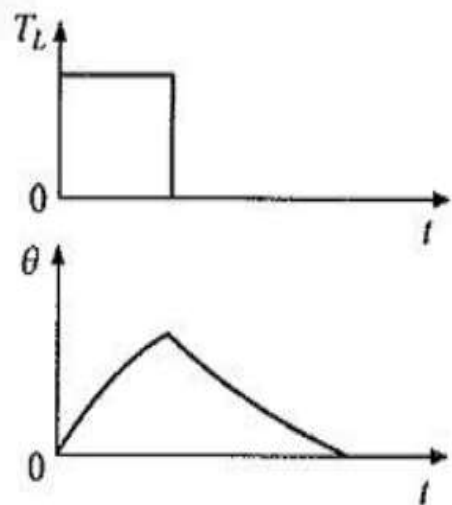

(b)

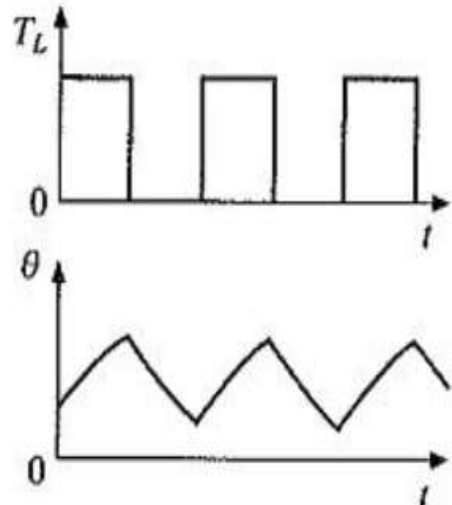

(c)

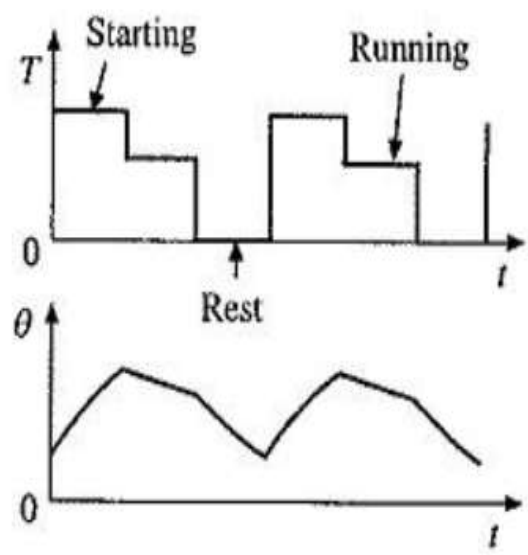

(d)

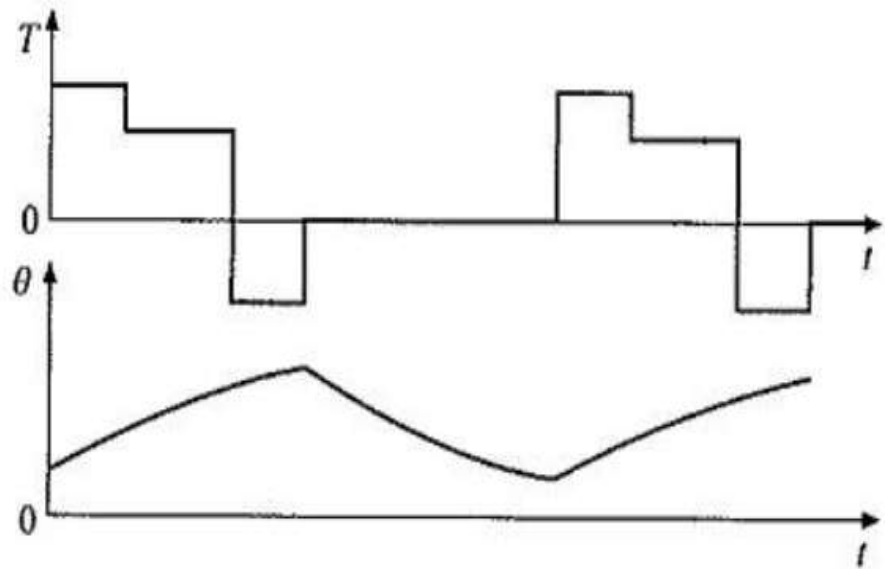

(e)

1. Continuous duty and constant load

✓ If the motor has load torque of T N-m and it is running at w radians/seconds, if efficiency in η , then power (W) rating of the motor is

$$P = \frac{2\pi}{60} * \frac{TN}{\eta}$$

✓ Power rating is calculated and then a motor with next higher power rating from commercially available rating is selected.

✓ Obviously, motor speed should also match load's speed requirement. It is also necessary to check whether the motor can fulfill starting torque requirement also.



Summary

- ✓ While starting a motor for this type it is not necessary to give importance to the heating caused by losses at the starting even though they are more than the losses at the rated load.
- ✓ This is because the motor does not require frequent starting.
- ✓ It is started only once in its duty cycle and the losses during starting do not have much influence on heating .
- ✓ Selection of there type motors is simple and straight forward.
- ✓ These type of motors need not be checked for thermal capacities rather it take care during the design .



2. Continuous duty and variable load

- ❖ The operating temperature of a motor should never exceed the maximum permissible temperature, because it will result in deterioration and breakdown of insulation and will shorten the service life of motors.
 - ❖ It is general practice to base the motor power ratings on a standard value of temperature, say 35°C .
 - ❖ Accordingly, the power given on the name plate of a motor corresponds to the power which the motor is capable of delivering without overheating at an ambient temperature of 35°C .
 - ❖ The rating of a machine can be determined from heating considerations.
- 

- ✓ Load is not constant, in one cycle it has several steps
- ✓ If a motor is selected accordingly to the lowest load, it may not be able to drive the load satisfactorily as the temperature rise of the motor will be exceedingly high and it may not have sufficient capacity to drive the highest load.
- ✓ If a motor is selected accordingly to the highest load, it becomes overheated and may have poor efficiency.
- ✓ For ac drive, power factor is poor which makes the motor unutilized.
- ✓ So, the choice of the motor based on the average power or average current.
- ✓ **Disadvantage:** It is a satisfactory method if the load fluctuations are relatively small.

❖ Therefore it becomes extremely difficult to select the motor capacity through analysis of the load diagram due to select the motor capacity through analysis of the load diagram due to lack of accuracy of this method.

On the other hand it is not correct to select the motor according to the lowest or highest load because the motor would be overloaded in the first case and under loaded in the second case. Therefore it becomes necessary to adopt suitable methods for the determination of motor ratings.

Methods used

The four commonly used methods are:

- 1 Methods of average losses
- 2 Equivalent current method
- 3 Equivalent torque method
- 4 Equivalent power method

1. Methods of average losses

∅ The method consists of finding average losses Q_{av} in the motor when it operates according to the given load diagram.

∅ These losses are then compared with the Q , the losses corresponding to the continuous duty of the machine when operated at its normal rating.

∅ The method of average losses presupposes that when $Q_{av} = Q_{nom}$, the motor will operate without temperature rise going above the maximum permissible for the particular class of insulation.



The figure shows a simple power load diagram and loss diagram for variable load conditions.

The losses of the motor are calculated for each portion of the load diagram by referring to the efficiency curve of the motor.

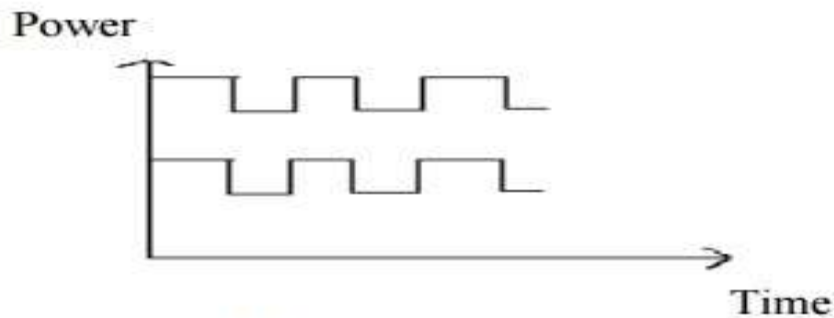

Fig 1.4 Average Load Losses

The average losses are given by

$$Q_{av} = \frac{Q_1 t_1 + Q_2 t_2 + Q_3 t_3 + \dots + Q_n t_n}{t_1 + t_2 + \dots + t_n}$$



- ❖ In case ,the two losses are equal or differ by a small amount ,the motor is selected .if the losses differ considerably ,another motor is selected and the calculations repeated till a motor having almost the same losses as the average losses is found.
- ❖ It should be checked that the motor selected has a sufficient overload capacity and starting torque.

- ❖ The method of average losses does not take into account, the maximum temperature rise under variable load conditions However, this method is accurate and reliable for determining the average temperature rise of the motor during one work cycle.

- ✓ The disadvantage of this method is that it is tedious to work with and also many a times the efficiency curve is not readily available and the efficiency has to be calculated by means of empirical formula which may not be accurate.

2. Equivalent Current Method

The equivalent current method is based on the assumption that the actual variable current may be replaced by an equivalent current I_{eq} which produces the same losses in the motor as the actual current.

$$I_{eq} = \sqrt{\frac{I_1^2 t_1 + I_2^2 t_2 + I_3^2 t_3 + \dots + I_n^2 t_n}{t_1 + t_2 + t_3 + \dots + t_n}}$$

The equivalent current is compared with the rated current of the motor selected and the conditions $I_{eq} \leq I_{nom}$ should be met. I_{nom} is the rated current of the machine.



Load diagram of Intermittent load

$$I_{eq} = \sqrt{\frac{I_1^2 t_1 + I_2^2 t_2 + \dots + I_n^2 t_n}{t_1 + t_2 + \dots + t_n}}$$

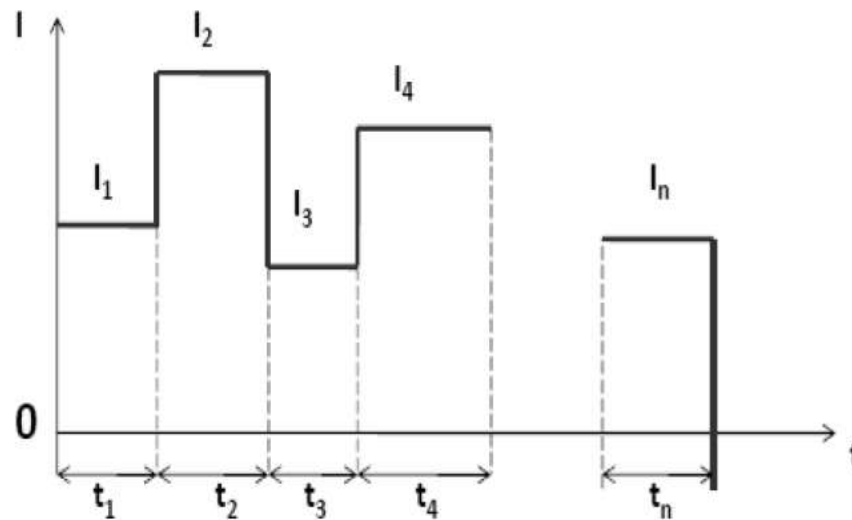

If the current varies smoothly over a period T, I_{eq} is: -

$$I_{eq} = \sqrt{\frac{1}{T} \int_0^T i^2 dt}$$

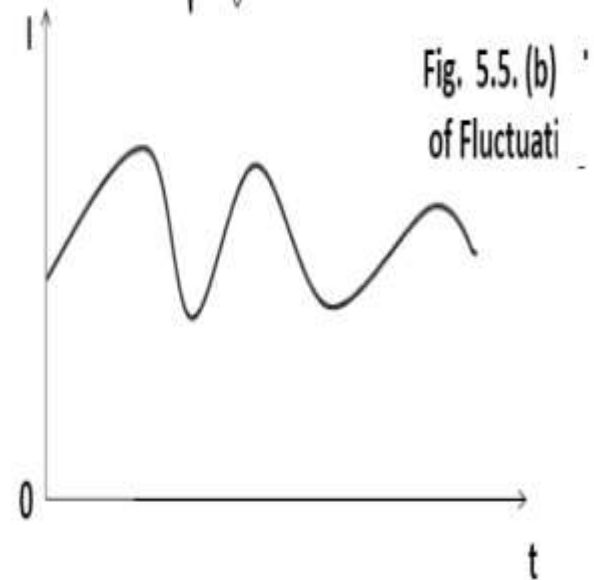

The machine selected should also be checked for its overload capacity,

For DC Motors:

$$\frac{I_{\max}}{I_{\text{nom}}} \leq 2 \text{ to } 2.5$$

For Induction Motors:

$$\frac{I_{\max}}{I_{\text{nom}}} \leq 1.65 \text{ to } 2.75$$

$$\frac{T_{\max}}{T_{\text{nom}}} \leq 1.65 \text{ to } 2.75$$

I_{\max} = Maximum current during work cycle

T_{\max} = Maximum load torque

T_{nom} = Torque of the motor at rated power and speed



3. Equivalent torque method

Assuming constant flux and power factor, torque is directly proportional to current.

$$T = \sqrt{\frac{T_1^2 t_1 + T_2^2 t_2 + \dots + T_n^2 t_n}{t_1 + t_2 + \dots + t_n}}$$

4. Equivalent power method

The equation for equivalent power method, power is directly proportional to torque.

At constant speed or where the changes in speed are small, the equivalent power is given by the following relationship,

$$P_{eq} = \sqrt{\frac{P_1^2 t_1 + P_2^2 t_2 + \dots + P_n^2 t_n}{t_1 + t_2 + \dots + t_n}}$$



Numerical

EXAMPLE 4.2

A rolling mill driven by thyristor converter-fed dc motor operates on a speed reversing duty cycle. Motor field current is maintained constant at the rated value. Moment of inertia referred to the motor shaft is $10,000 \text{ kg-m}^2$. Duty cycle consists of the following intervals:

- (i) Rolling at full speed (200 rpm) and at a constant torque of 25,000 N-m for 10 sec.
- (ii) No load operation for 1 sec at full speed.
- (iii) Speed reversal from 200 to -200 rpm in 5 sec.
- (iv) No load operation for 1 sec at full speed.
- (v) Rolling at full speed and at a torque of 20,000 N-m for 15 sec.
- (vi) No load operation at full speed for 1 sec.
- (vii) Speed reversal from -200 to 200 rpm in 5 sec.
- (viii) No load operation at full speed for 1 sec.

Determine the torque and power ratings of the motor.

Solution

Since in a dc motor, at constant field current the torque is proportional to armature current, torque rating can be evaluated by determining the rms value of torque.

$$\begin{aligned} \text{Torque during reversal} &= J \frac{d\omega}{dt} = 10000 \frac{[200 - (-200)] \times (2\pi/60)}{5} \\ &= 83776 \text{ N-m} \end{aligned}$$

$$T_{\text{rms}} = \sqrt{\frac{25000^2 \times 10 + (83776^2 \times 5) \times 2 + 20000^2 \times 15}{39}} = 47,686 \text{ N-m}$$

Continue.....

Maximum torque 83776 N-m is only 1.76 times T_{rms} . If motor rating is chosen to be 47686 N-m, the maximum current will be only 1.76 times the rated current. In a dc motor twice the rated current can always be allowed during transient operation. Therefore, motor can be rated equal to T_{rms} . Thus, motor torque rating

$$T_{rated} = 47686 \text{ N-m}$$

$$\text{Power rating} = 47686 \times \frac{200}{60} \times 2\pi = 998.7 \text{ kW}$$

EXAMPLE 4.3

A constant speed drive has the following duty cycle:

- (i) Load rising from 0 to 400 kW : 5 min
- (ii) Uniform load of 500 kW : 5 min
- (iii) Regenerative power of 400 kW returned to the supply : 4 min
- (iv) Remains idle for : 2 min

Estimate power rating of the motor. Assume losses to be proportional to (power)².

Solution

Rated power = rms value of power P_{rms} . Now the rms value of the power in interval (i)

$$P_1 = \sqrt{\frac{1}{5} \int_0^5 \left(\frac{400}{5} x \right)^2 dx} = \frac{400}{\sqrt{3}} \text{ kW}$$

$$P_{rms} = \sqrt{\frac{\left(\frac{400}{\sqrt{3}} \right)^2 \times 5 + 500^2 \times 5 + 400^2 \times 4}{16}} = 367 \text{ kW}$$

Since $P_{max} = 500 \text{ kW}$ is less than two times P_{rms} , motor rating = 367 kW.

Equivalent torque and power methods of determination of rating for intermittent loads.

3. Short time rating of motor

An electric motor of rated power P_r subjected to its rated load continuously reaches its permissible temperature rise after due to time. If the same motor is to be used for short time duty, it can take up more load for a short period without increasing the maximum permissible temperature of the motor during this period.

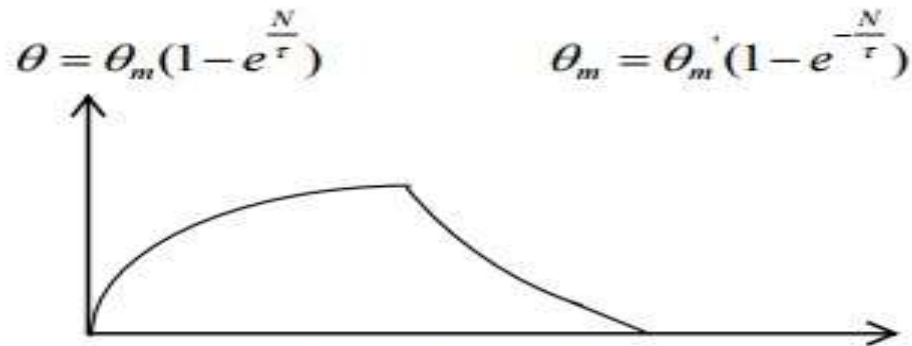

Fig 1.6 Short time motor rating

Using the temperature rise curve the short time rating of the given motor can be determined.

Referring to the fig. , the motor having a continuous rating of P_r is used to drive the load P so that it reaches θ_{\max} (θ_{per}) at the end of t_r .

$$\theta_{\text{per}} = \theta_{ss} (1 - e^{-t_r/\tau}) \dots\dots\dots(1)$$

$$\frac{\theta_{ss}}{\theta_{\text{per}}} = \frac{1}{(1 - e^{-t_r/\tau})} \dots\dots\dots(2)$$

$$\theta_{ss} = \frac{Q}{A} \dots\dots\dots(3)$$

Qdt = The heat in calories produced in motor in time

$A\tau dt$ = The amount of heat dissipated into the atmosphere in t time for a temperature τ and emissivity A (cal per sec per $^{\circ}\text{C}$)

Qdt = The heat in calories produced in motor in time

$A\tau dt$ = The amount of heat dissipated into the atmosphere in t time for a temperature τ and emissivity A (cal per sec per $^{\circ}\text{C}$)

θ_{ss} is the steady state temperature rise which will be attained if motor delivers a power P_r on continuous basis, whereas the permissible temperature rise θ_{per} is also the steady state temperature rise attained when motor operates with a power P_r on continuous basis. If the motor losses for powers P_r and P_r be P_{lr} and P_{ls} respectively, then from (3),

$$\frac{\theta_{ss}}{\theta_{per}} = \frac{P_{ls}}{P_{lr}} = \frac{1}{(1 - e^{-t/\tau})} \dots\dots\dots(4)$$

$$P_{lr} = P_c + P_{cu} = P_{cu}(\alpha + 1) \dots\dots\dots(5)$$

Where $\frac{P_c}{P_{cu}} = \alpha$, P_c is the constant loss (load independent) and P_{cu} the load dependent loss.

$$P_{1s} = P_c + P_{cu} \left(\frac{P_r'}{P_r} \right)^2 \dots\dots\dots(6)$$

Let $k = \left(\frac{P_r'}{P_r} \right)$ = overloading factor, and putting in (6), $P_{1s} = P_c + k^2 P_{cu} \dots\dots\dots(7)$

Substituting (5) and (7) into (4) gives

$$\frac{\alpha + k^2}{\alpha + 1} = \frac{1}{(1 - e^{-t/\tau})} \dots\dots\dots(8)$$

$$k = \sqrt{\frac{1 + \alpha}{1 - e^{-t/\tau}} - \alpha} \dots\dots\dots(9)$$

Overloading factor (k) can be calculated when constant and copper losses are known separately. When losses are separately not known, total loss is assumed to be only proportional to (power)².

While speed varies in wide limits during the operation of motor, changes occur in heating and cooling phenomenon of the motors. In those cases, method equivalent current, torque or power cannot be employed.

Let us consider a simple intermittent load, where the motor is alternately subjected to a fixed magnitude load P_f of duration t_f and standstill condition of duration t_s .

As the motor is subjected to a periodic load, after thermal steady state is reached the temperature rise will fluctuate between a maximum value θ_{\max} and a minimum value θ_{\min} . For this load, the motor rating should be selected such that $\theta_{\max} \leq \theta_{ps}$,

Temperature at the end of working interval is given by

$$\theta_{\max} = \theta_{ss} (1 - e^{-t_f/\tau_f}) + \theta_{\min} e^{-t_f/\tau_f} \quad \dots\dots\dots(10)$$

And fall the temperature rise at the end of standstill interval t_s will be

$$\theta_{\min} = \theta_{\max} e^{-t_s/\tau_s} \quad \dots\dots\dots(11)$$

Where τ_f and τ_s are the thermal time constants of motor for working and standstill intervals.

Combining (1) and (2),

$$\frac{\theta_{ss}}{\theta_{\max}} = \frac{1 - e^{\{(-t_f/\tau_f) + (t_s/\tau_s)\}}}{1 - e^{-t_f/\tau_f}} \quad \dots\dots\dots(12)$$

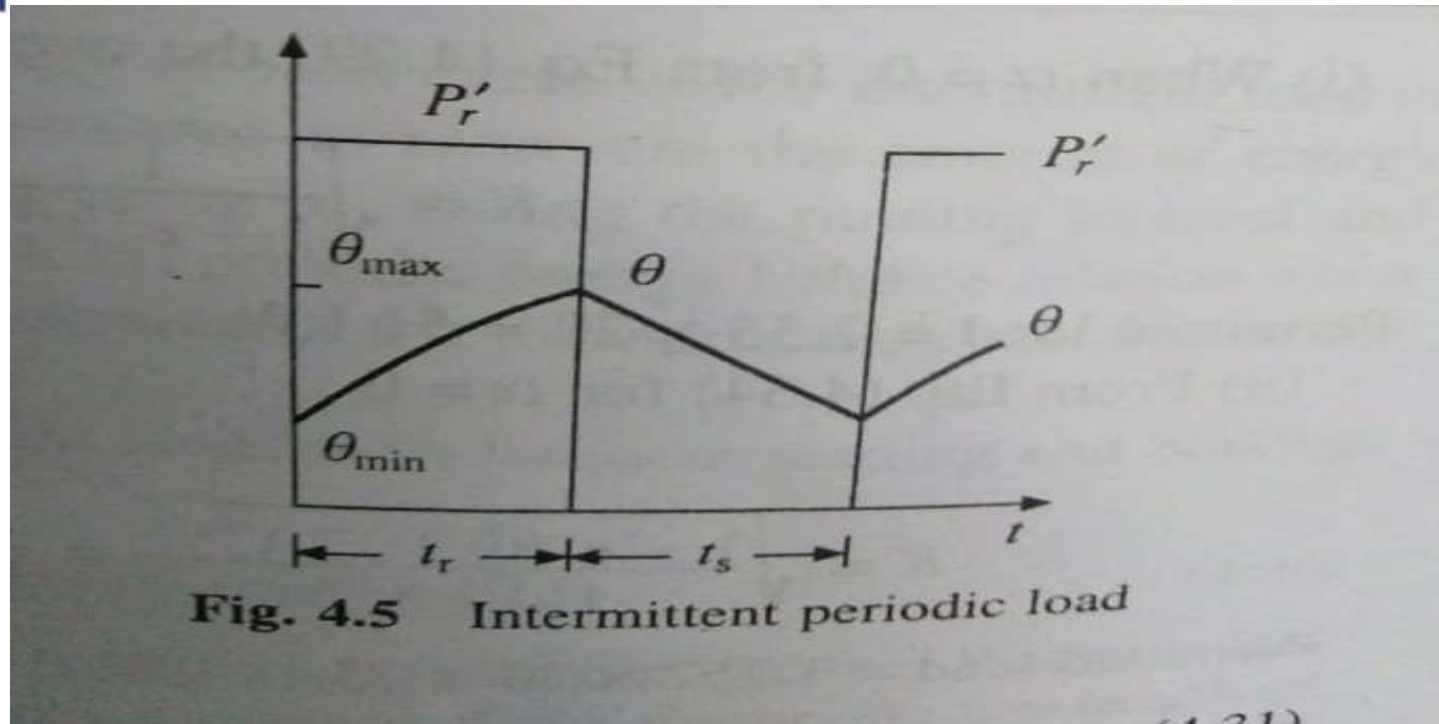

Fig. 4.5 Intermittent periodic load

We know,

$$\frac{\theta_{ss}}{\theta_{per}} = \frac{P_{lr}}{P_{lr}} \dots\dots\dots(13)$$

From (6), (8), (12) and (13) overloading factor can be written as

$$k = \sqrt{(\alpha + 1) \frac{1 - e^{-\{(-t_r/\tau_r) + (t_r/\tau_r)\}}}{1 - e^{-t_r/\tau}} - \alpha} \dots\dots\dots(14)$$

Numerical

EXAMPLE 4.4

A motor has a heating time constant of 60 min and cooling time constant of 90 min. When run continuously on full load of 20 kW, the final temperature rise is 40°C.

- (i) What load motor can deliver for 10 min if this is followed by a shunt down period long enough for it to cool?
- (ii) If it is on an intermittent load of 10 min followed by 10 min shut down, what is the maximum value of load it can supply during the on load period?

Solution

As the constant and copper losses are not available separately, they are assumed proportional to $(\text{power})^2$ and therefore α is assumed to be zero.

(i) When $\alpha = 0$, from Eq. (4.29) the overloading factor is

$$K = \sqrt{\frac{1}{1 - e^{-t_r/\tau}}} = \sqrt{\frac{1}{1 - e^{-10/60}}} = 2.55$$

Permitted load = $2.55 \times 20 = 51$ kW.

(ii) From Eq. (4.34) for $\alpha = 0$

$$K = \sqrt{\frac{1 - e^{-((t_r/\tau_r) + (t_s/\tau_s))}}{1 - e^{-t_r/\tau_r}}} = \sqrt{\frac{1 - e^{-\left(\frac{10}{60} + \frac{10}{90}\right)}}{1 - e^{-10/60}}} = \sqrt{\frac{0.2425}{0.1535}} = 1.257$$

Permitted load = $1.257 \times 20 = 25.14$ kW.

EXAMPLE 4.5

Half hour rating of a motor is 100 kW. Heating time constant is 80 min and the maximum efficiency occurs at 70% full load. Determine the continuous rating of the motor.

Solution

Let P kW be the continuous rating of motor and p_c the constant loss.

Then at $0.7P$, copper loss = constant loss p_c

$$\text{At } P \text{ copper loss} = \left(\frac{P}{0.7P}\right)^2 p_c = \frac{P_c}{0.49}$$

$$\alpha = \frac{P_c}{P_{cu}} = \frac{P_c}{P_c/0.49} = 0.49$$

Substituting in Eq. (4.29)

$$K = \sqrt{\frac{1 + 0.49}{1 - e^{-30/80}}} - 0.49 = 2.0676$$

Therefore, the continuous rating = $\frac{100}{2.0676} = 48.37$ kW

5.2 A motor has a heating time constant of 90 minutes. If the temperature rise of the motor is 100°C when it is continuously loaded with its rated load determine the temperature rise of the motor after 2 hours of its rated load. If the temperature after 2 hours reaches the maximum permissible temperature (final steady-state temperature with rated load applied continuously) after it is overloaded, determine the permissible overloading. Assume constant losses = 0.5 of full load copper losses.

Solution

Temperature rise after 2 hours of continuous loading

$$= 100 \left(1 - e^{-\frac{2}{1.5}} \right) = 73.64^{\circ}\text{C}$$

$$100 = \theta_m \left(1 - e^{-\frac{2}{1.5}} \right) = \theta_m \times 0.7364$$

$$\theta_m = 135.8^{\circ} \frac{W_c}{W_{cu}} = \alpha$$

$$\frac{135.8}{100} = \frac{W_c + x^2 W_{cu}}{W_c + W_{cu}} = \frac{\alpha + x^2}{\alpha + 1}$$

$$1.358(\alpha + 1) = \alpha + x^2$$

$$0.358\alpha + 1.358 = x^2$$

$$\alpha = 0.5$$

$$x = 1.24$$

An overloading of 24% can be allowed

5.3 The heating and cooling time constants of an electric motor are 100 and 150 minutes respectively. The rating of the motor is 125 kW. If it is working on duty cycle of 15 minutes on load and 30 minutes on no-load determine the permissible overloading of the motor. Assume the losses are $P_c + x^2 P_{cu}$ and $P_c/P_{cu} = \alpha = 0.4$.

Solution

The ratio

$$\frac{P_x}{P_r} = \sqrt{\frac{(\alpha + 1)(1 - e^{-z} \cdot e^{-y})}{1 - e^{-z}}} - \alpha$$

$$e^{-z} = e^{-\frac{15}{100}} = 0.861$$

$$e^{-y} = e^{-\frac{30}{150}} = 0.819$$

$$\frac{P_x}{P_r} = \sqrt{\frac{(1.4)(0.295)}{1 - 0.86}} - 0.4 = 1.596$$

It can be overloaded by 0.596

The intermittent rating = 199.55 kW

MULTIPLE CHOICE QUESTIONS

- 5.1 The heating time constant of an electrical machine gives an indication of its
(a) cooling (b) rating
(c) overload capacity (d) short time rating
- 5.2 Short time rating of an electrical machine
(a) is equal to name plate rating
(b) is less than the name plate rating
(c) is greater than the name plate rating
(d) has no bearing to its name plate rating
- 5.3 All the physical dimensions of two electric machines are in the ratio K . The iron losses of the machines are in the ratio (assuming constant flux density in both the cases)
(a) K (b) K^2 (c) K^3 (d) K^4
- 5.4 Class B insulation can withstand a maximum temperature of
(a) 145°C (b) 105°C (c) 135°C (d) 120°C
- 5.5 The rating of a motor for a given industrial load cycle should have
(a) sufficient thermal capacity (b) sufficient over load capacity
(c) both of the above (d) sufficient starting torque
- 5.6 A machine driving pulsed torque load is equipped with a flywheel in order to
(a) equalise the current demand during the operation
(b) equalise the torque requirement
(c) reduce the mechanical overload
(d) make the motor thermally suitable to drive the load
- 5.7 Two motors of the same name plate details have different thermal time constants.
(a) The short time ratings of the two motors are the same
(b) The short time rating of the motor with large time constant is large
(c) The short time rating of the motor with large time constant is small
(d) Overload capacity of the motor with large time constant is large.

Load Equalization, Calculation of time and Energy loss in transient operations

Load Equalisation in Electrical Drives

Definition: Load equalisation is the process of smoothing the fluctuating load. The fluctuate load draws heavy current from the supply during the peak interval and also cause a large voltage drop in the system due to which the equipment may get damage.

In load equalisation, the energy is stored at light load, and this energy is utilised when the peak load occurs. Thus, the electrical power from the supply remains constant.

Necessity of load Equalization

The load fluctuation mostly occurs in some of the drives. For example, in a pressing machine, a large torque is required for a short duration. Otherwise, the torque is zero. Some of the other examples are a rolling mill, reciprocating pump, planing machines, electrical hammer, etc.

In electrical drives, the load fluctuation occurs in the wide range. For supplying the peak torque demand to electrical drives the motor should have high ratings, and also the motor will draw pulse current from the supply.

The amplitude of pulse current gives rise to a line voltage fluctuation which affected the other load connected to the line.

Role of Flywheel in load Equalization

The problem of load fluctuation can be overcome by using the flywheel. The flying wheel is mounted on a motor shaft in non-reversible drives.

In variable speed and reversible drive, a flywheel cannot be mounted on the motor shaft as it will increase the transient time of the drive.

If the motor is fed from the motor generator set, then flywheel mounted on the motor generator shaft and hence equalises the load on the source but not load on the motor.

Method of Load Equalisation

- ✓ When the load is light, the flywheel accelerated and stored the excess energy drawn from the supply.
- ✓ During the peak load, the flying wheel decelerates and supply the stored energy to the load along with the supply energy.
- ✓ Hence the power remains constant, and the load demand is reduced

Moment of inertia of the flying wheel required for load equalisation is calculated as follows. Consider the linear motor speed torque curve as shown in the figure below.

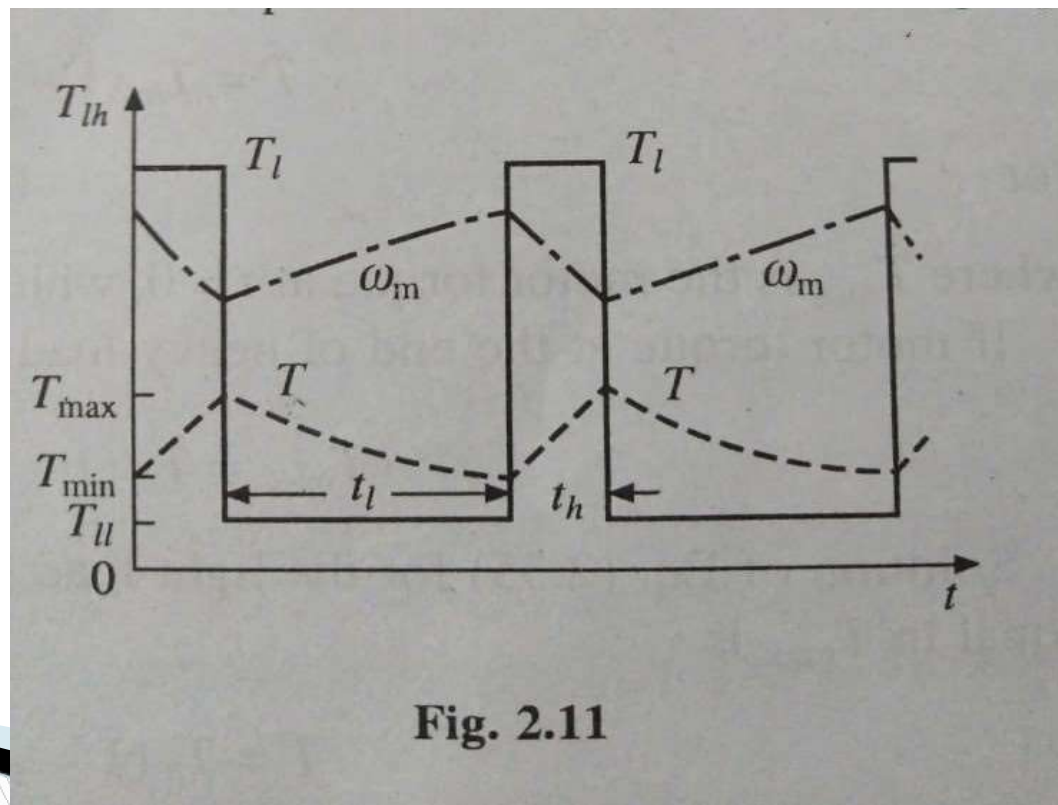
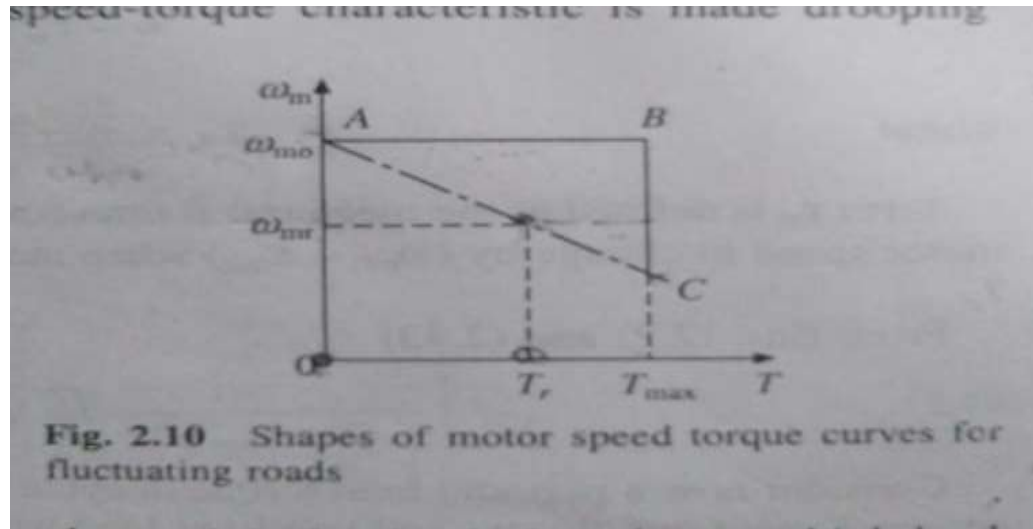

$$\omega_m = \omega_{m0} - \frac{\omega_{m0} - \omega_{mr}}{T_r} \times T \dots \dots \dots \text{equ(1)}$$

Assumed the response of the motor is slow due to large inertia and hence applicable for transient operation. Differentiate the equation (1) and multiply both sides by J (moment of inertia).

$$J \frac{d\omega_m}{dt} = \frac{J(\omega_{m0} - \omega_{mr})}{T_r} \frac{dT}{dt} \dots \dots \dots \text{equ(2)}$$

$$J \frac{d\omega_m}{dt} = -T_m \frac{dT}{dt} \dots \dots \dots \text{equ(3)}$$

$$T_m = \frac{(\omega_{m0} - \omega_{mr})}{T_r} \dots \dots \dots \text{equ(4)}$$

Where T_m is the mechanical time constant of the motor. It is the time required for the motor speed to change by $(\omega_{m0} - \omega_{mr})$ when motor torque is maintained constant at rated value T_r . From equation(2) and (3)

$$T_m \frac{dT}{dt} + T = T_l \dots \dots \dots \text{equ(5)}$$

Consider a periodic load torque a cycle which consists of one high load period with torque T_1 and duration t_1 , and one light load period with torque T_2 and duration t_2 .

$$T = T_{lh} \left(1 - e^{-t/\tau_m}\right) + T_{max} e^{-t/\tau_m} \dots \dots \dots \text{equ}(6)$$

$$\text{for } 0 \leq t \leq t_h$$

Where T_{min} is the motor torque at $t = 0$ which is also the instant when heavy load T_{lh} is applied. If motor torque at the end of heavy load period is T_{max} , then from the equation (6)

Solution of equation (5) for the light load period with the initial motor torque equal to T_{max} is

$$T_{max} = T_{lh} \left(1 - e^{-t/\tau_m}\right) + T_{max} e^{-t/\tau_m} \dots \dots \dots \text{equ}(7)$$

$$T = T_{ll} \left(1 - e^{-t'/\tau_m}\right) + T_{max} e^{-t'/\tau_m} \dots \dots \dots \text{equ}(8)$$

$$\text{for } 0 \leq t' \leq t_h$$

where $t' = t - t_h$. When operating at steady state the motor torque at the end of a cycle will be the same as at the beginning of a cycle. Hence at $t' = t_h$, $T = T_{min}$. Substituting in equation (8) give

$$T_{min} = T_{ll} \left(1 - e^{-t_h/\tau_m}\right) + T_{max} e^{-t_h/\tau_m} \dots \dots \dots \text{equ}(9)$$

From equ (7)

$$\tau_m = \frac{t_h}{\log_e \left(\frac{T_{lh} - T_{min}}{T_{lh} - T_{max}} \right)} \dots \dots \dots \text{equ(10)}$$

From equ (4) and (10)

$$J = \frac{T_r}{(\omega_{m0} - \omega_{mr})} \times \frac{t_h}{\log_e \left(\frac{T_{lh} - T_{min}}{T_{lh} - T_{max}} \right)} \dots \dots \dots \text{equ(11)}$$

From equ (9)

$$\tau_m = \frac{t_1}{\log_e \left(\frac{T_{lh} - T_{min}}{T_{lh} - T_{max}} \right)} \dots \dots \dots \text{equ(12)}$$

From equ (4) and (11)

$$J = \frac{T_r}{(\omega_{m0} - \omega_{mr})} \times \frac{t_1}{\log_e \left(\frac{T_{lh} - T_{min}}{T_{lh} - T_{max}} \right)} \dots \dots \dots \text{equ(13)}$$

Moment of inertia of the flywheel required can be calculated either from equation(11) and (12)

Calculation of time and energy loss in transient operations

Transient time and energy loss can be computed with satisfactory accuracy using steady state speed-torque and speed current curves of motor and speed-torque curve of load.

$$dt = \frac{J}{T(\omega_m) - T_l(\omega_m)}$$

$T(\omega_m)$ and $T_l(\omega_m)$ indicate that the motor and load torques are functions of drive speed ω_m

Time taken for speed to change from ω_{m1} to ω_{m2} is obtained by integrating the above equation

$$t = J \int_{\omega_{m1}}^{\omega_{m2}} \frac{d\omega_m}{T(\omega_m) - T_l(\omega_m)}$$

Calculation of time and energy loss in transient operations

❖ The transient time can be evaluated by measuring this area

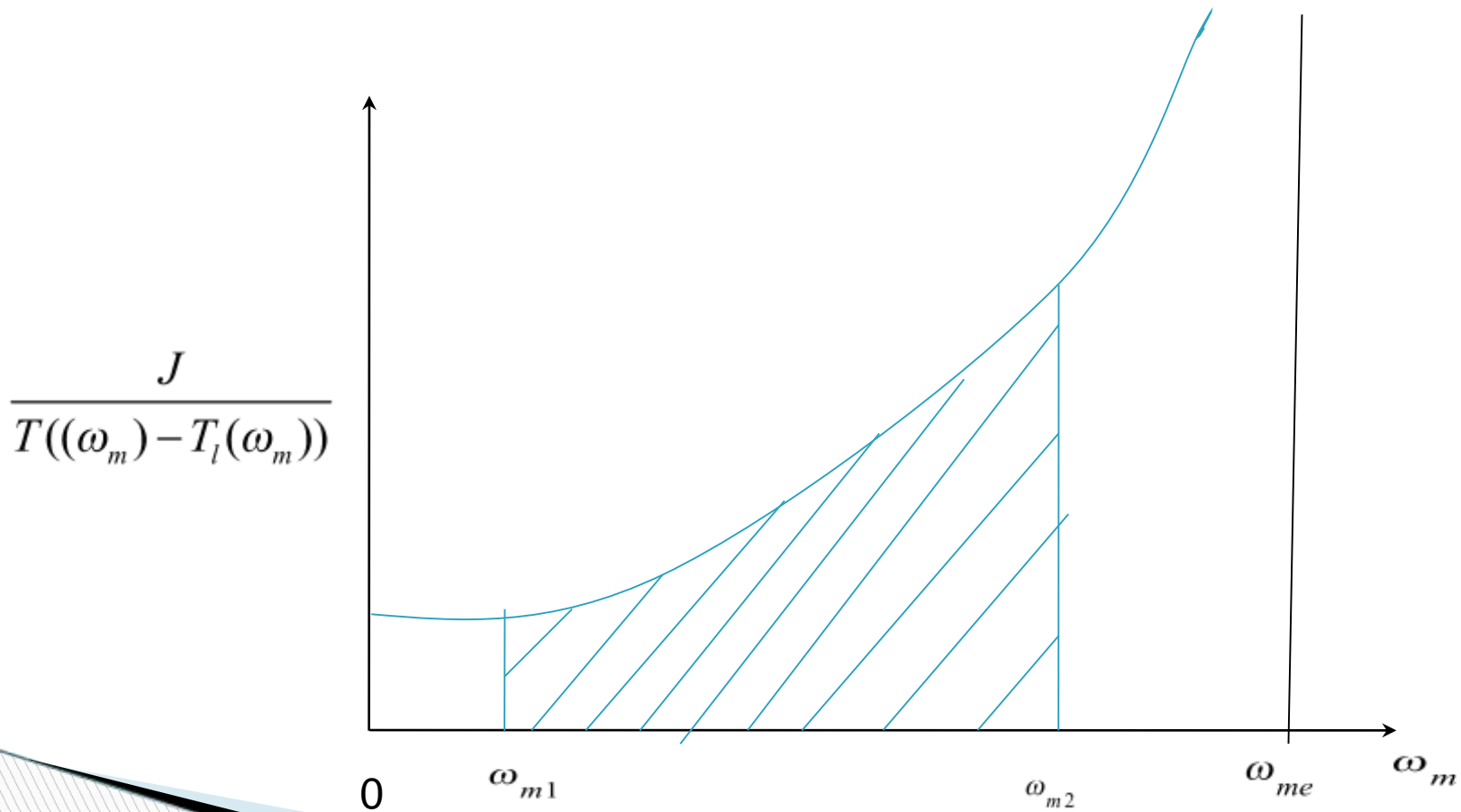

Energy Required in a motor winding during a transient operation is given by

$$E = \int_0^t Ri^2 dt$$

Where R is the motor winding resistance and i is the current flowing through it

EXAMPLE 2.2

A drive has following parameters:

$J = 10 \text{ kg-m}^2$, $T = 100 - 0.1N$, N-m, Passive load torque $T_l = 0.05N$, N-m,
 where N is the speed in rpm.

Initially the drive is operating in steady-state. Now it is to be reversed. For this motor characteristic is changed to $T = -100 - 0.1N$, N-m. Calculate the time of reversal.

Solution

For steady-state speed

$$T - T_l = 0$$

or

$$100 - 0.1N - 0.05N = 0$$

or

$$0.15N = 100 \quad \text{or} \quad N = 666.7 \text{ rpm}$$

After reversal, for steady-state speed, noting that the load is passive

$$-100 - 0.1N - 0.05N = 0$$

or

$$N = -666.7 \text{ rpm}$$

When reversing, from Eq. (2.2)

$$J \frac{d\omega_m}{dt} = -100 - 0.1N - 0.05N$$

$$\frac{dN}{dt} = \frac{30}{J\pi} (-100 - 0.15N) = -95.49 - 0.143N$$

$$t = \int dt = \int_{N_1}^{N_2} \frac{dN}{-95.49 - 0.143N}$$

where $N_1 = 666.7$ rpm and $N_2 = 0.95 \times -666.7 = -633.4$ rpm*.

Integrating Eq. (1) yields $t = 25.58$ S.

2.7 STEADY STATE STABILITY

Equilibrium speed of a motor-load system is obtained when motor torque eq Drive will operate in steady-state at this speed, provided it is the speed of Concept of steady-state stability has been developed to readily evaluate equilibrium point from the steady-state speed-torque curves of the motor and solution of differential equations valid for transient operation of the drive.

In most drives, the electrical time constant of the motor is negligible compared to the mechanical time constant. Therefore, during transient operation, motor can be assumed

EXAMPLE 2.5

A motor equipped with a flywheel is to supply a load torque of 1000 N-m for 10 sec followed by a light load period of 200 N-m long enough for the flywheel to regain its steady-state speed. It is desired to limit the motor torque to 700 N-m. What should be the moment of inertia of flywheel? Motor has an inertia of 10 kg-m². Its no load speed is 500 rpm and the slip at a torque of 500 N-m is 5%. Assume speed-torque characteristic of motor to be a straight line in the region of interest.

Solution

From Eq. (2.42)

$$J = \frac{T_r}{(\omega_{m0} - \omega_{mr})} \left[\frac{t_h}{\log_e \left(\frac{T_{lh} - T_{min}}{T_{lh} - T_{max}} \right)} \right] \quad (1)$$

$$\text{Here no load speed} = \frac{500 \times 2\pi}{60} = 52.36 \text{ rad/sec}$$

$$\text{Speed at 500 N-m} = (1 - 0.05) 52.36 = 49.74 \text{ rad/sec}$$

28 *Fundamentals of Electrical Drives*

$$\frac{T_r}{(\omega_{m0} - \omega_{mr})} = \frac{500}{52.36 - 49.74} = 190.84$$

$$T_{th} = 1000 \text{ N-m}, T_{max} = 700 \text{ N-m}, T_{min} = T_{ll} = 200 \text{ N-m}, t_h = 10 \text{ S.}$$

Substituting in Eq. (1)

$$J = 190.84 \left[\frac{10}{\log_e \left(\frac{1000 - 200}{1000 - 700} \right)} \right] = 1871.8 \text{ kg-m}^2$$

Moment of inertia of the flywheel = $1871.8 - 10 = 1861.8 \text{ kg-m}^2$.

PROBLEMS

2.1 A drive has the following parameters:

$T = 150 - 0.1N$, N-m, where N is the speed in rpm.

Load torque $T_l = 100$, N-m

Initially the drive is operating in steady-state. The characteristics of the

$T = 100$ N-m

METHODS OF STARTING OF ELECTRIC MOTORS, DETERMINATION OF ACCELERATION TIME

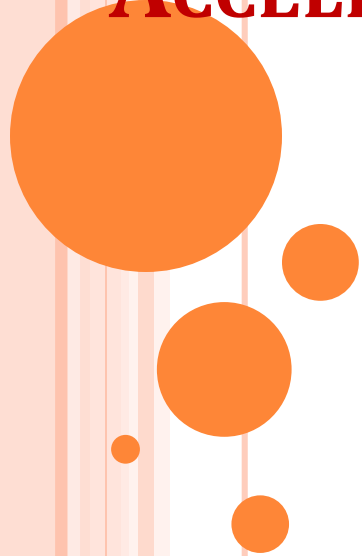

METHODS OF STARTING OF ELECTRIC MOTORS

An induction motor is similar to a poly-phase transformer whose secondary is short circuited. Thus, at normal supply voltage, like in transformers, the initial current taken by the primary is very large for a short while.

Unlike in DC motors, large current at starting is due to the absence of back emf. If an induction motor is directly switched on from the supply, it takes 5 to 7 times its full load current and develops a torque which is only 1.5 to 2.5 times the full load torque. This large starting current produces a large voltage drop in the line, which may affect the operation of other devices connected to the same line.

Hence, it is not advisable to start induction motors of higher ratings (generally above 25kW) directly from the mains supply. Various **starting methods of induction motors** are described below.

Effect of starting on Power supply, motor and load.

Transient processes involved with the starting of the (drive) motor in a variable speed drive require a detailed study. The electric motor and connected load accelerates to the rated speed from rest under the influence of the starting torque.

The transient operation during is satisfactory if a sufficiently good starting torque is developed with a reduced value of starting current, to accelerate the rotor in the desired amount of time.

The need to limit the starting current arises due to heavy dips of the voltage of the motor following starting peaks of current. The starting equipment used should be capable of minimizing these dips in the voltage to a tolerable value, so that the other equipment on the network is not affected.

The starting current affects the motor also. High starting currents heat up the rotor. If starting is frequent, the heating needs to be reduced or limited. In dc machines high starting currents produce sparking at the brushes. For good commutation the starting currents must be limited. .

DIRECT-ON-LINE (DOL) STARTERS

Small three phase induction motors can be started direct-on-line, which means that the rated supply is directly applied to the motor.

Induction motors can be started directly on-line using a DOL starter which generally consists of a contactor and a motor protection equipment such as a circuit breaker.

A DOL starter consists of a coil operated contactor which can be controlled by start and stop push buttons. When the start push button is pressed, the contactor gets energized and it closes all the three phases of the motor to the supply phases at a time. The stop push button de-energizes the contactor and disconnects all the three phases to stop the motor.

In order to avoid excessive voltage drop in the supply line due to large starting current, a DOL starter is generally used for motors that are rated below 5kW.

STARTING OF SQUIRREL CAGE MOTORS

Starting in-rush current in squirrel cage motors is controlled by applying reduced voltage to the stator. These methods are sometimes called as **reduced voltage methods for starting of squirrel cage induction motors.**

For this purpose, following methods are used:

By using primary resistors

- Autotransformer
- Star-delta switches



Using primary resistors:

Obviously, the purpose of primary resistors is to drop some voltage and apply a reduced voltage to the stator. Consider, the starting voltage is reduced by 50%.

This method is generally used for a **smooth starting of small induction motors**. It is not recommended to use primary resistors type of starting method for motors with high starting torque requirements. At the time of starting, full resistance is connected in the series with the stator winding and it is gradually decreased as the motor speeds up. When the motor reaches an appropriate speed, the resistances are disconnected from the circuit and the stator phases are directly connected to the supply lines.

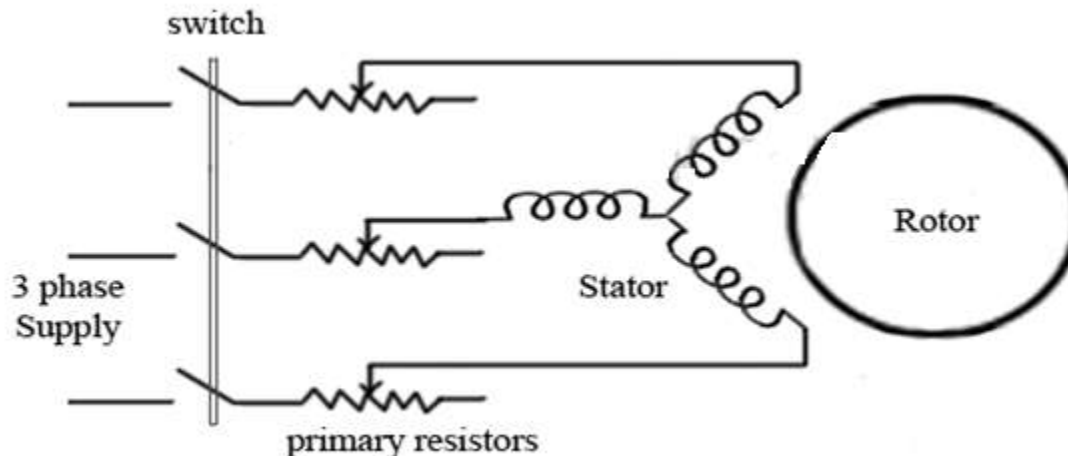

2. Auto-transformers

Auto-transformers are also known as auto-starters. They can be used for both star connected or delta connected squirrel cage motors.

With auto-transformer starting, the current drawn from supply line is always less than the motor current by an amount equal to the transformation ratio

The internal connections of an auto-starter are as shown in the figure. At starting, switch is at "start" position, and a reduced voltage (which is selected using a tap) is applied across the stator.

When the motor gathers an appropriate speed, say upto 80% of its rated speed, the auto-transformer automatically gets disconnected from the circuit as the switch goes to "run" position.

The switch changing the connection from start to run position may be air-break (small motors) or oil-immersed (large motors) type. There are also provisions for no-voltage and overload, with time delay circuits on an autostarter.

2. Auto-transformers

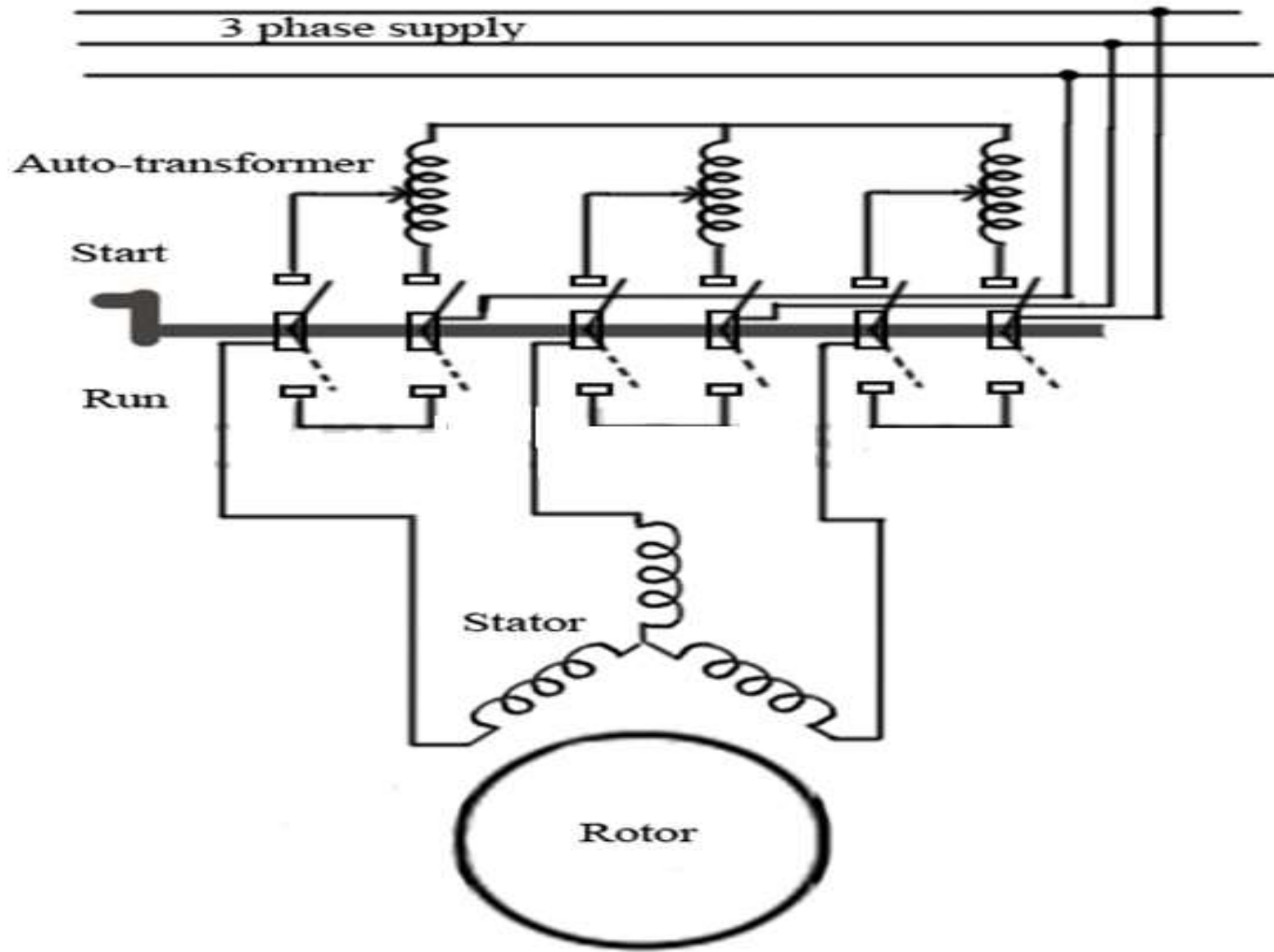

3. Star-delta starter

This method is used in the motors, which are designed to run on delta connected stator. A two way switch is used to connect the stator winding in star while starting and in delta while running at normal speed.

When the stator winding is star connected, voltage over each phase in motor will be reduced by a factor $1/(\text{sqrt. } 3)$ of that would be for delta connected winding. The starting torque will $1/3$ times that it will be for delta connected winding.

Hence a star-delta starter is equivalent to an auto-transformer of ratio $1/(\text{sqrt. } 3)$ or 58% reduced voltage.



Starting of slip-ring motors

Slip-ring motors are started with full line voltage, as external resistance can be easily added in the rotor circuit with the help of slip-rings.

A star connected rheostat is connected in series with the rotor via slip-rings as shown in the fig. Introducing resistance in rotor current will decrease the starting current in rotor (and, hence, in stator).

Also, it improves power factor and the torque is increased. The connected rheostat may be hand-operated or automatic

As, introduction of additional resistance in rotor improves the starting torque, slip-ring motors can be started on load. The external resistance introduced is only for starting purposes, and is gradually cut out as the motor gathers the speed.



Starting of slip-ring motors

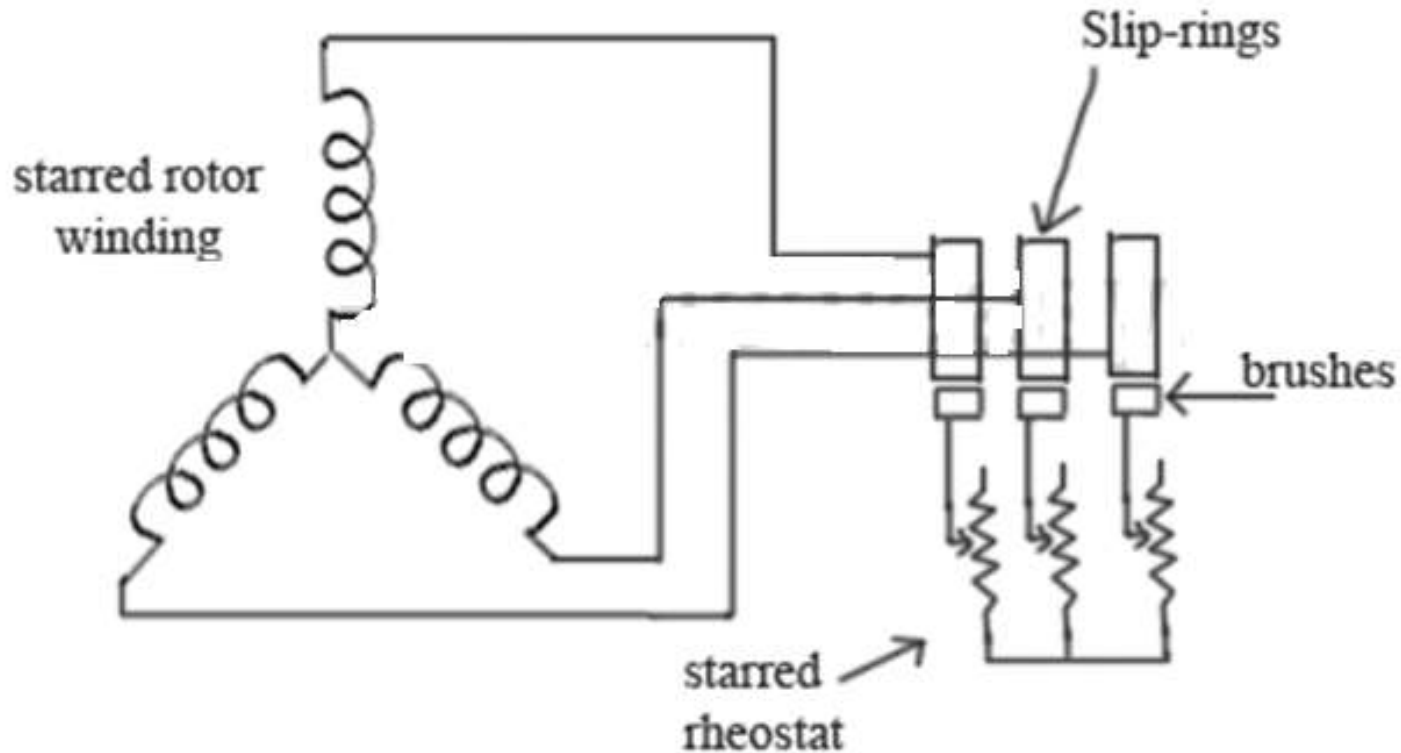

Phase wound rotor connections



MOTOR STARTING ELEMENTS

Motor Starting Time:

Motor starting time refers to when the electric supply is hooked to the time the motor accelerates to its full speed. The motor starting time length depends on both the mechanical and electrical load the system carries. It can range from just less than a second to half a minute or longer.

Starting Current:

During the motor start-up, a particularly high amount of current is needed. However, this could spell trouble for the electrical system supplying the motor and other equipment attached to it.

Starting Transients:

The transients refer to the duration of time it takes for the motor to run up to its designed speed after motor starting. This is dependent on the characteristic of load, both mechanical and electrical.



The starting torque must produce uniform acceleration. Acceleration time must be reduced with a view to improving the productivity and to reduce the energy lost during starting.

The purpose of starting equipment in an electric motor is to limit the starting current and to provide a reasonably good starting torque, if possible, so that the motor accelerates in the desired period to the rated speed. For dc motors the starting current is limited by using an additional resistance in series with the armature. The motor is switched on with full field. This is effectively reduced voltage starting. Thyristor power converters used for speed control may also be used for the purpose of starting, since the voltage is smoothly variable and starting losses are absent.

Induction motors are started by any of the following methods:

1. Direct on line starting
2. Low voltage starting
3. Rotor resistance starting
4. Low frequency starting
5. Special rotor construction.



Energy lost during starting of DC shunt Motor



Starting of Electric Drives.

Energy losses occur in motor during periods of changing speed, like starting, breaking and sudden changes in applied voltage, load etc.

DC shunt Motor : (separately excited d.c. motor)

The voltage equation of the DC Motor,

$$V = E_b + I_a R_a$$

$$I_a R_a = V - E_b \quad \text{--- (1)}$$

For shunt motor, $I_a R_a = V - k\omega$ --- (2)

$$\left[\begin{array}{l} \because E_b = \text{back emf} = \frac{\phi Z N P}{60 A} \\ \therefore E_b \propto N \quad (\because N \text{ is speed in rpm}) \end{array} \right.$$

$$E_b = k \phi N = k \omega \quad \left[\omega = 2\pi N \text{ (rad/s)} \right]$$

The equation of motor at no load

$$T_M = K I_a \quad (\because T_M \propto I_a \phi)$$

$$= J \frac{d\omega}{dt} \quad \text{--- (3)} \quad \left(T_M = K I_a \right)$$

where $k = \text{const}$

Multiplying eqⁿ (2) & (3)

$$K I_a^2 R_a = V J \frac{d\omega}{dt} - J k \omega \frac{d\omega}{dt}$$

$$I_a^2 R_a = \frac{V J}{K} \frac{d\omega}{dt} - J \cdot \omega \frac{d\omega}{dt}$$

At no load, $I_a R_a$ will be negligibly small.
So from eqⁿ (2)

$$V - k\omega = 0 \quad \text{--- (5)}$$

at ~~no~~ no load, $\omega = \omega_0 = \text{no load speed}$

$$V = k\omega_0 \quad \text{--- (6)}$$

So, from eqⁿ (6) & eqⁿ (4)

$$I_a^2 R_a = \frac{\omega_0 J}{K} \frac{d\omega}{dt} - J \omega \frac{d\omega}{dt}$$

$$I_a^2 R_a dt = \frac{\omega_0 J}{K} d\omega - J \omega d\omega$$

If the motor starts with constant Load torque

$$I_a R_a = v - k\omega \quad (1)$$

at no load, $v = k\omega_0$ ($\omega_0 =$ no load speed)

$$v, \quad T_M = kI_a \quad \& \quad \text{also, } T_M = T_L + J \frac{d\omega}{dt}$$

$$\text{or } kI_a = T_L + J \frac{d\omega}{dt} \quad (2)$$

Multiply eqⁿ (1) & (2)

$$kI_a R_a = v T_L - k\omega T_L + v J \frac{d\omega}{dt} - kJ\omega \frac{d\omega}{dt}$$

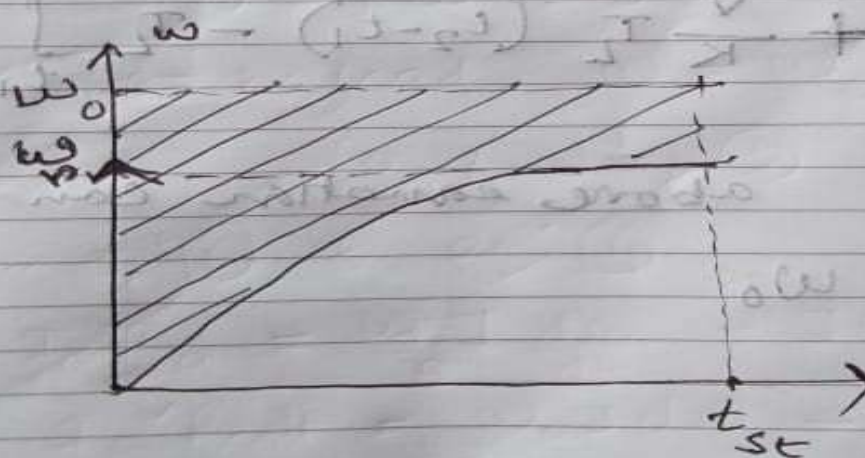

If the motor speed were to change from ω_1 to ω_2 from t_1 to t_2 , energy dissipated in armature circuit

$$W = \int_{t_1}^{t_2} I_a^2 R_a dt$$

$$= \int_{\omega_1}^{\omega_2} J \omega_0 d\omega = \int_{\omega_1}^{\omega_2} J \omega d\omega$$

$$= J \omega_0 (\omega_2 - \omega_1) - \frac{J}{2} (\omega_2^2 - \omega_1^2)$$

Energy loss during starting, when the motor changes its speed from zero to no load speed ω_0 will be

$$W_{st} = J \omega_0 - \frac{J}{2} \omega_0^2$$

as, $\omega_2 = \omega_0$ & $\omega_1 = 0$

Therefore energy lost during starting on load, when the speed ω changes from zero to ω_n , will be .

$$W_{st} = J\omega_0\omega_n - \frac{J}{2}\omega_n^2 + \omega_0 T_L t_{st} - T_L \int_0^t \omega(t) dt .$$

where t_{st} = accelerating time .

If the motor starts with constant Load torque

$$I_a R_a = v - k\omega \quad (1)$$

at no load, $v = k\omega_0$ ($\omega_0 =$ no load speed)

$$v, \quad T_M = kI_a \quad \& \quad \text{also, } T_M = T_L + J \frac{d\omega}{dt}$$

$$\text{or } kI_a = T_L + J \frac{d\omega}{dt} \quad (2)$$

Multiply eqⁿ (1) & (2)

$$kI_a R_a = vT_L - k\omega T_L + vJ \frac{d\omega}{dt} - kJ\omega \frac{d\omega}{dt}$$

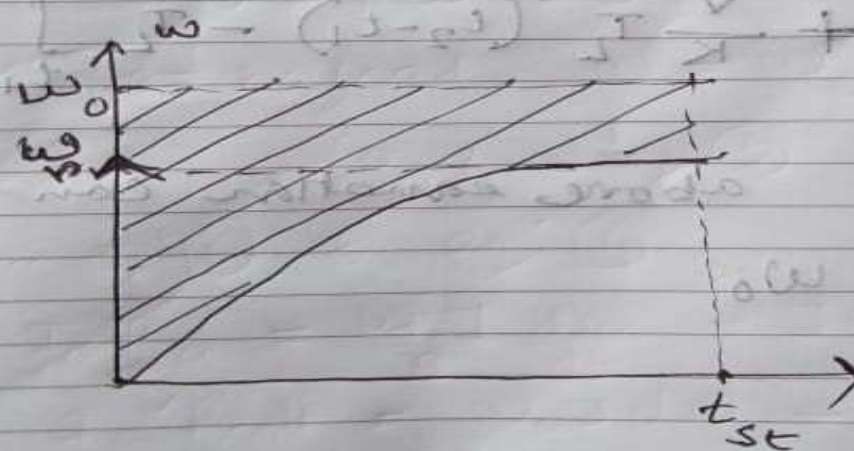

Energy lost during starting of DC series Motor

08am Energy loss during starting of

09am DC Series Motor:

10am

11am Since a dc series motor should not
 be started on no load, let us assume
 a constant load torque T_L to be present,
 Noon while determining the energy loss during
 starting.

01pm

The equation of torque will be

02pm

$$T_M = K I_a^2 = J \frac{d\omega}{dt} + T_L$$

03pm

Total energy dissipated in the armature
 circuit resistance is

04pm

05pm

$$W = \int_{t_1}^{t_2} I_a^2 R_a dt$$

Sunday 19

Even

07pm

$$= \int_{\omega_1}^{\omega_2} \frac{J R_a d\omega}{K} + \int_{t_1}^{t_2} T_L R_a$$

Work to do

$$W = \frac{J R_a (\omega_2 - \omega_1)}{K} + \frac{T_L R_a (t_2 - t_1)}{K} \text{ Joules}$$

Energy lost during starting of Three Phase Induction Motor

Energy loss during starting of
Three phase Induction Motor :

In a three phase induction motor,

$$\text{torque } (T) = \frac{3}{\omega_c} I_2^2 \frac{R_2}{s} \quad \text{--- (1)}$$

Neglecting load and friction torques in motor

$$T = J \frac{d\omega}{dt} = -J \omega_c \frac{ds}{dt} \quad \left[\because \frac{d\omega_c}{dt} = 0 \right] \quad \text{--- (2)}$$

$$\left[\text{as } \omega = \omega_c (1-s) \right]$$

$\omega_c =$ Synchronous speed in rps and it is constant.

So, total energy loss in the rotor resistance of induction motor, when its slip changes from s_1 to s_2 given as

$$W = 3 \int_{t_1}^{t_2} I_2^2 R_2 dt \quad \text{--- (3)}$$

$t_1 \rightarrow s_1$ & $t_2 \rightarrow s_2$

So, ~~W~~ = Equating eqⁿ (1) & eqⁿ (2)

08am $3I_2^2 R_2 = -j\omega_s \frac{ds}{dt}$ (4)

09am

10am So, substituting eqⁿ (4) in eqⁿ (3)

11am

$$W = -j\omega_s \int_{s_1}^{s_2} ds$$

Noon

01pm

$$= \frac{1}{2} j\omega_s^2 (s_1^2 - s_2^2) \text{ Joules}$$

02pm

03pm

During starting, the slip of IM changes from 1 to 0 and hence energy lost in the rotor circuit is

04pm

05pm

$$W_{st} = \frac{1}{2} j\omega_s^2 \text{ Joules} \quad (5)$$

Even

07pm

Although energy lost in the rotor circuit is independent of R_2 , the energy lost in the stator will be decreased by an increase in R_2 , so that the total energy lost in the motor can be decreased by an increase in R_2 .

During the change of speed, the total energy can be obtained

$$W_m = 3 \int_{t_1}^{t_2} I_2^2 (R_1 + R_2) dt \quad \text{--- (5)}$$

$$\left[\text{as } I_2 \approx I_1 \right]$$

$$\left[\& I_1 R_1 = I_2 R_2 \right]$$

$$\therefore \left[\frac{R_1}{R_2} = \frac{I_2}{I_1} \right]$$

So, ~~W_m =~~ $\frac{1}{2} J \omega_s^2$

Put $3 I_2^2$ value from eq. (4) in eq. (5) --- (6)

$$W_m = \int_{t_1}^{t_2} \left(\frac{J \omega_s^2 s}{R_2} \frac{ds}{dt} \right) (R_1 + R_2) dt$$

$$= \left(1 + \frac{R_1}{R_2} \right) \int_{s_1}^{s_2} J \omega_s^2 (s ds)$$

$$W_m = \frac{1}{2} J \omega_s^2 \left(1 + \frac{R_1}{R_2} \right) (s_1^2 - s_2^2)$$

During starting, Energy lost is given by

$$W_{st} = \frac{1}{2} J \omega_s^2 \left(1 + \frac{R_1}{R_2} \right)$$

[as at starting $s_1 = 1$
 $s_2 = 0$]
 $\therefore s = \text{slip}$

Methods of reduction of Energy loss

1. Reducing the moment of inertia of the motor
2. Starting of dc shunt motor by smooth adjustment of applied voltage
3. Starting of multispeed induction motor in discrete steps of speed
4. Starting of induction motor by smooth variation of supply frequency (v/f control)

1.Reducing the moment of inertia of the motor

The total Energy loss in motors during transient operation can be reduced

By reducing the moment of inertia of the drive system.

A single motor of certain power rating can be replaced by two motors of one half rating

As a consequence of such a change, motors with a smaller diameter and hence reduced moment of inertia will be employed.

Use specially designed motors having large axial length.

For the same power rating and speed of rotation , these motors will have smaller diameter than the general purpose motors

Starting of dc shunt motor by smooth adjustment of applied voltage

Since the speed of DC shunt motor directly proportional to the applied voltage, the steps will be of equal magnitude, if the voltage is varied in equal steps. Therefore the loss of energy during starting with m equal steps of voltage can be expressed as

$$W_{st} = \frac{1}{m} \left[\frac{1}{2} J (\omega_0)^2 \right]$$

It is obvious that larger the steps in voltage, less will be the energy loss during starting.

Starting of Multispeed Induction motor in discrete steps

Pole changing motors of two or more ratios of speeds can be started in discrete steps of speed.

Since there is no changes in the expression for energy loss during starting of an induction motor from that of DC shunt motor, it can be easily interpret that this method of starting will also involve only less energy loss during starting.

Starting of induction motor by smooth variation of supply frequency (v/f control)

Just as in the case of DC shunt motor being started by smooth adjustment of applied voltage, this method will involve changes in speed in a very large number of steps

If the speed steps are equal in magnitude and a large number of steps in frequency are effected, the loss in energy during starting will be given by the expression

$$W_{st} = \frac{1}{m} \left[\frac{1}{2} J \omega_0^2 \right]$$

Review of DC Motor Drives:

DC drives are widely used in applications requiring adjustable speed, good speed regulation and frequent starting, braking, and reversing. Although since late sixties, it is being predicted that AC drives would replace DC drives, even today the variable speed applications are dominated by DC drives because of lower cost, reliability and simple control.

DC motors and their performance:

Basic schematic diagrams of DC separately excited, shunt and Series motors are shown in the figure below.

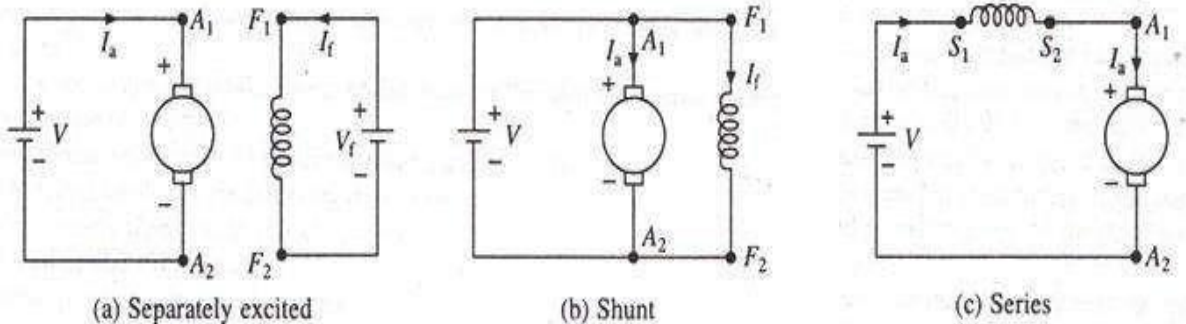

Fig: Basic Schematic digarams of DC motors

- In a separately excited DC motor the field and armature are connected to separate voltage sources and can be controlled independently.
- In a shunt motor the field and the armature are connected to the same source and cannot be controlled independently.
- In a series motor the field current and armature current are same and hence the field flux is dependent on armature current.

The Steady state equivalent circuit of a DC motor Armature is shown in the figure below.

From the above three equations we get the Basic general relation between Torque and speed as:

$$\begin{aligned}\omega &= (E_a / K_a \cdot \Phi) - (R_a / K_a \cdot \Phi) \cdot I_a \\ &= (E_a / K_a \cdot \Phi) - [R_a / (K_a \cdot \Phi)^2] \tau.\end{aligned}$$

Shunt and Separately excited motors:

In their case with a constant field current the field flux can be assumed to be constant and then $(K_a \cdot \Phi)$ would be another constant K . Then the above Torque speed relations would become :

$$\begin{aligned}\omega &= (E_a / K) - (R_a / K) \cdot I_a \\ &= [E_a / K] - [R_a / K^2] \cdot \tau\end{aligned}$$

The Speed/ Torque Characteristics of a DC Separately Excited Motor for rated terminal voltage and full field current are shown in the figure below. It is a drooping straight line.

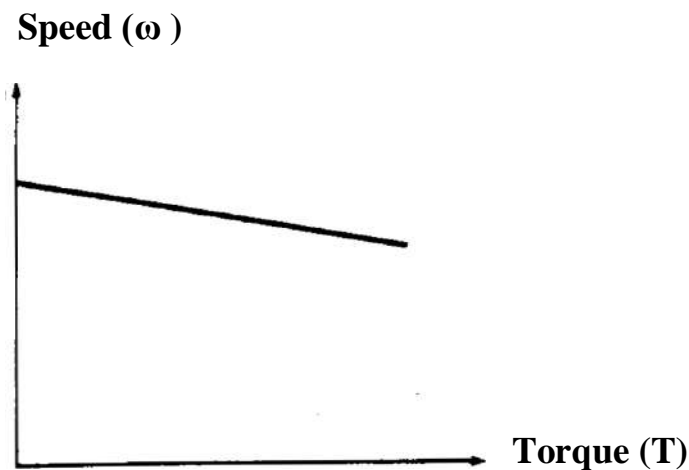

Fig: Speed/ Torque Characteristics of a DC Separately Excited Motor

The no load speed is given by the Applied armature terminal voltage and the field current. Speed falls with increasing load torque. The speed regulation depends on

the Armature circuit resistance. The usual drop from no load to full load in the case of a medium sized motor will be around 5%. Separately excited motors are mostly used in applications where good speed regulation and adjustable speed are required.

Series Motor: In series motors the field flux Φ is dependent on the armature current I_a and can be assumed to be proportional to the armature current in the unsaturated region of the magnetization characteristic. Then

$$\Phi = K_f \cdot I_a$$

And using this value in the three general motor relations given earlier we get

$$T = K_a \cdot \Phi \cdot I_a = K_a \cdot K_f \cdot I_a^2 \text{ and}$$

$$\omega = E_a / K_a \cdot K_f \cdot I_a - (R_{af} / K_a \cdot$$

$$K_f) \omega = *E_a / \sqrt{(K_{af} \cdot \tau)} - -$$

$$[R_a / (K_{af})]$$

Where R_{af} is now the sum of armature and field winding resistances and $K_{af} = K_a \cdot K_f$ is the total motor constant. The Speed-Torque characteristics of a DC series motor are shown in the figure below.

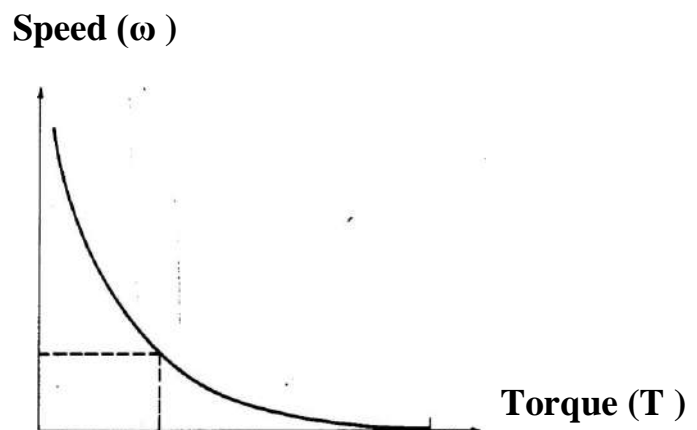

Rated speed and Rated Torque

Fig: Speed-Torque characteristics of a DC series

motor

- Series motors are suitable for applications requiring high starting torque and heavy overloads. Since Torque is proportional to square of the armature current, for a given increase in load torque the increase in armature current is less in case of series motor as compared to a separately excited motor where torque is proportional to only armature current. Thus during heavy overloads power overload on the source and thermal overload on the motor are kept limited to reasonable small values.
- According to the above Speed torque equation, as speed varies inversely to the square root of the Load torque, the motor runs at a large speed at light load. Generally the electrical machines' mechanical strength permits their operation up to about twice their rated speed. Hence the series motors should not be used in such drives where there is a possibility for the torque to drop down to such an extent that the speed exceeds twice the rated speed.

DC Motor speed control:

There are two basic methods of control

- Armature Voltage Control (AVC) and
- Flux control

Torque speed curves of both SE (separately Excited) motors and series motors using these methods are shown in the figure below.

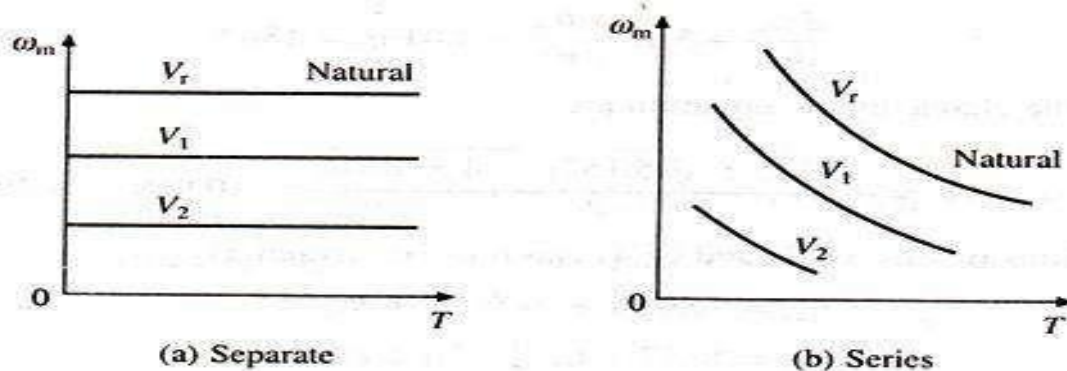

Fig: Torque speed curves with AVC : $V_r (V \text{ rated}) > V_1 > V_2$

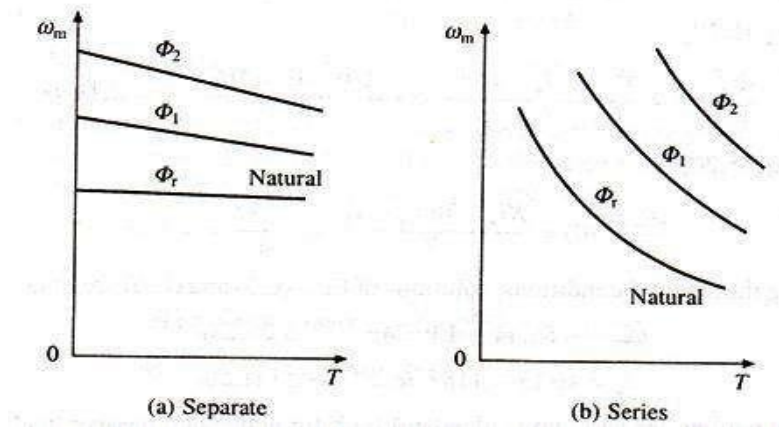

Fig: Torque speed curves with FC : Φ_r (Φ rated)

> $\Phi_1 > \Phi_2$) Important features of DC Motor speed control:

- AVC is preferred because of high efficiency, good transient response, and good speed regulation. But it can provide speed control below base speed only because armature voltage cannot exceed the rated value.
- For speeds above Base speed Field Flux Control is employed. In a normally designed motor the maximum speed can be twice the rated speed and in specially designed motors it can be up to six times the rated speed.
- AVC is achieved by Single and Three phase Semi & Full converters.
- FC in separately excited motors is obtained by varying the voltage across the field winding and in series motors by varying the number of turns in the field winding or by connecting a diverting resistance across the field winding.
- Due to the maximum torque and power limitations , DC Drives operating
 - With full field, AVC below base speed can deliver a constant maximum torque. This is because in AVC with full field, the Torque is proportional to I_a and consequently the torque that the motor can deliver has a maximum value.
 - With rated Armature Voltage, Flux control above base speed can deliver a constant maximum power. This is because at rated armature voltage, P_m is proportional to I_a and consequently the maximum power that can be developed by the motor has a constant value.

These limitations are shown in the figure below.

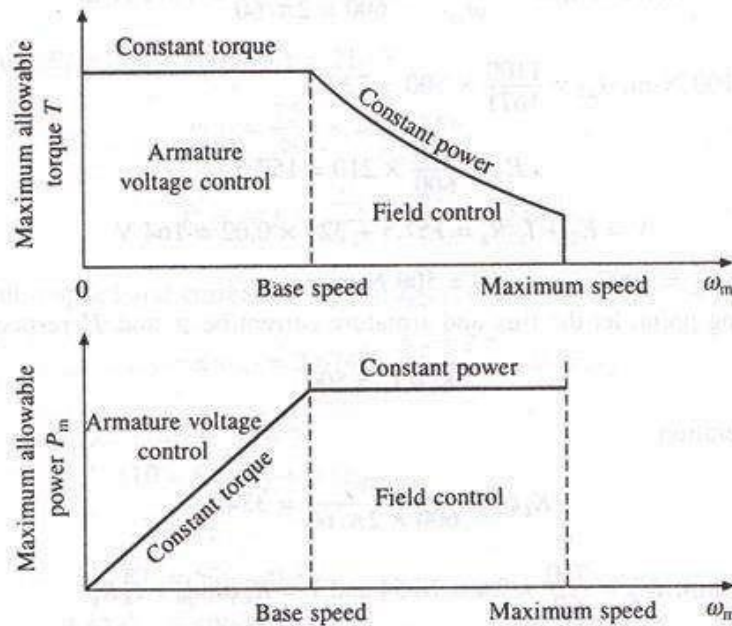

Fig: Torque and Power limitations in Combined Armature Voltage and Flux controls

Single phase Semi converter drives feeding a separately excited DC motor:

Semi converters are one quadrant converters. i.e. they have one polarity of voltage and current at the DC terminals. The circuit diagram of Semi converter feeding a DC separately excited motor is shown in the figure below. It consists of Two controlled rectifiers (Thyristors T1 and T2) in the upper limbs and two Diodes D1 and D2 in the lower limbs in a bridge configuration along with a freewheeling diode as shown in the figure below. The armature voltage is controlled by a 1ϕ semi converter and the field circuit is fed from a separate DC source. The motor current cannot reverse since current cannot flow in the reverse direction in the thyristors. In Semi converters the DC output voltage and current

are always positive. Therefore in drive systems using semi converters reverse power flow from motor to AC supply side is not possible. The armature current may be continuous or discontinuous depending on the operating conditions and circuit parameters. The torque speed characteristics would be different in the two modes of conduction. We will limit our study to Continuous conduction mode in this chapter.

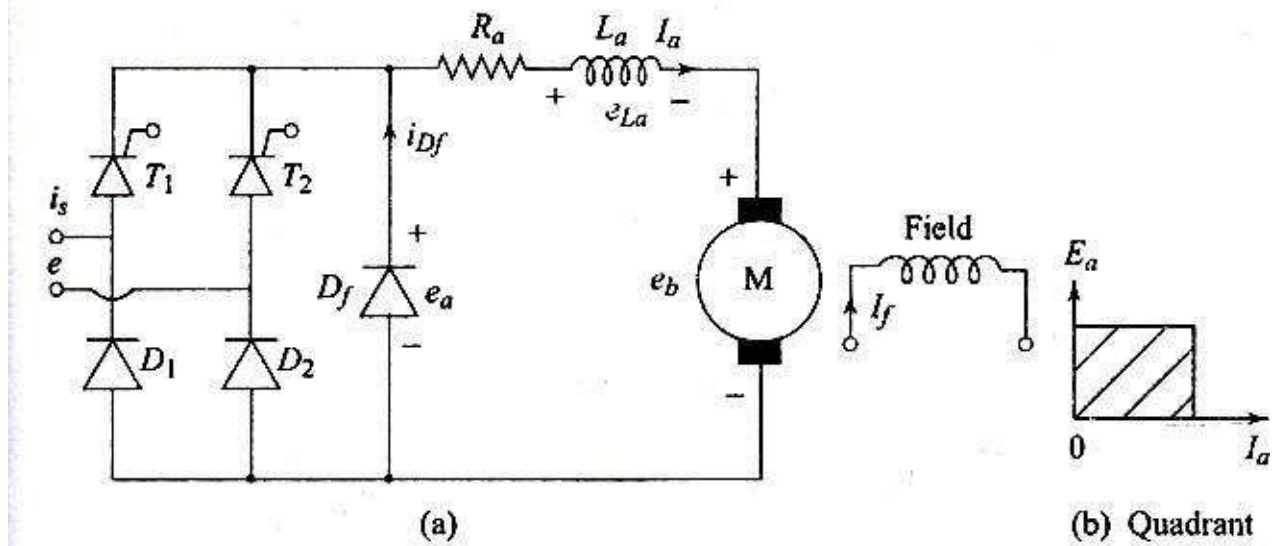

Fig: Single Phase Semi converter feeding a Separately Excited DC Motor

Performance of Semi Converter in Continuous Current Operation:

The voltage and current waveforms are shown in the figure below for operation in continuous current mode over the whole range of operation. SCR T1 is triggered at a firing angle α and T2 at the firing angle $(\pi + \alpha)$. During the period $\alpha < \omega t < \pi$ the motor is connected to the input supply through T1 and D2 and the motor terminal voltage e_a is the same as the input supply voltage 'e'. Beyond period π , e_a tends to reverse as the input voltage changes polarity. This will forward bias the freewheeling diode D_F and it starts conducting. The motor current i_a which was flowing from the supply through T1 is transferred to D_F (T1 gets commutated). Therefore during the period $\pi < \omega t < (\pi + \alpha)$ the motor terminals are shorted through D_F making e_a zero.

As explained above, when the thyristor conducts during the period $\alpha < \omega t < \pi$, energy from the supply is delivered to the armature circuit. This energy is partially stored in the Inductance, partially stored as kinetic energy in the moving system and partially used up in the load. During the freewheeling period $\pi < \omega t < (\pi + \alpha)$ energy is recovered from the Inductance and is converted to mechanical form to supplement the Kinetic energy required to run the load. The freewheeling armature current continues to produce the torque in the motor. During this period no energy is feedback to the supply.

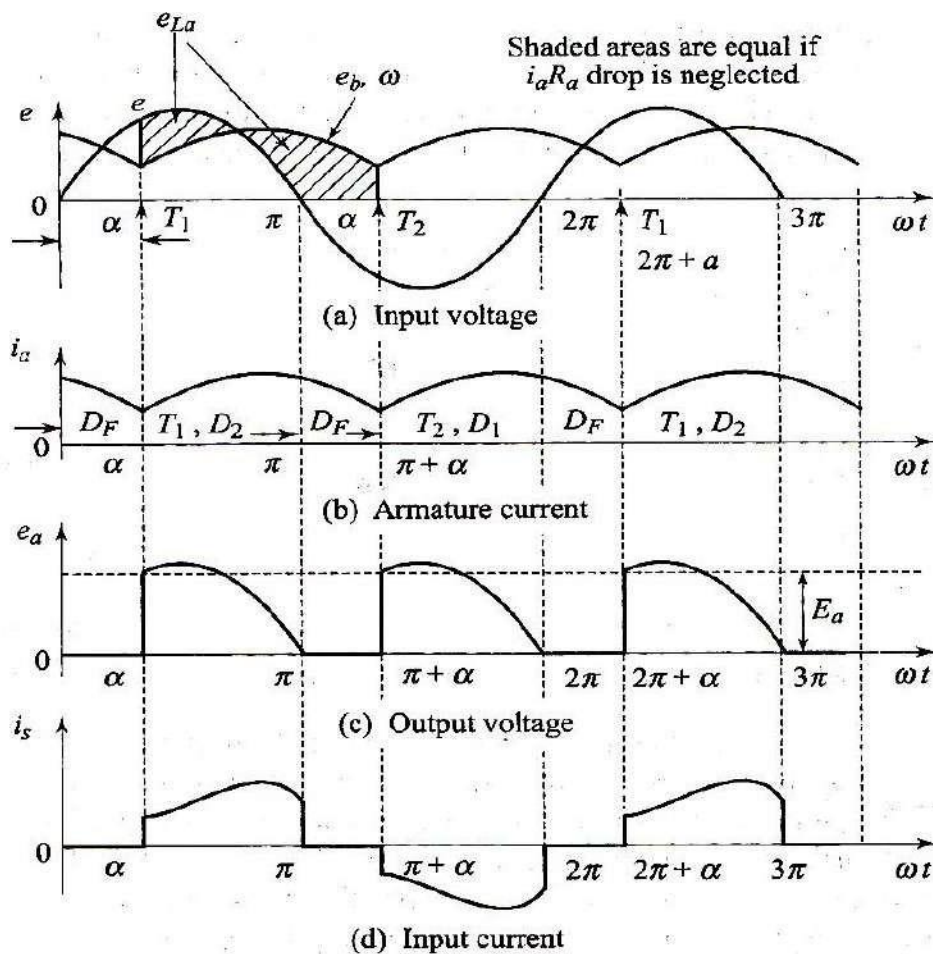

Fig: Voltage and Current waveforms for Continuous current operation in a single Phase semi controlled drive connected to a separately excited DC motor.

Torque Speed Characteristics of a Single phase Semi Converter connected to DC separately excited motor:

In terms of average voltages, KVL around the motor armature gives

$$E_a(\alpha) = E_b + I_a R_a = K_a \phi \cdot \omega + I_a R_a$$

Therefore

$$\omega = [E_a(\alpha) - I_a R_a] / K_a \phi$$

Assuming motor current to be continuous, the motor armature voltage as derived above for the single phase semi converter is given by:

$$E_{dc} = \frac{1}{\pi} \int_{\alpha}^{\pi} E_m \sin \omega t d(\omega t) = \frac{E_m}{\pi} [1 + \cos \alpha]$$

i.e. $E_a(\alpha) = (E_m/\pi)(1 + \cos \alpha)$

Using this in the above expression for speed ω we get

$$\omega = [(E_m/\pi)(1 + \cos \alpha) - I_a R_a] / K_a \phi$$

$$\omega = [(E_m/\pi)(1 + \cos \alpha) / K_a \phi] - [I_a R_a /$$

$$K_a \phi + \omega = [(E_m/\pi)(1 + \cos \alpha) / K_a \phi] - [R_a /$$

$$(K_a \phi)^2] \tau$$

The resulting torque speed characteristics are shown in the figure below.

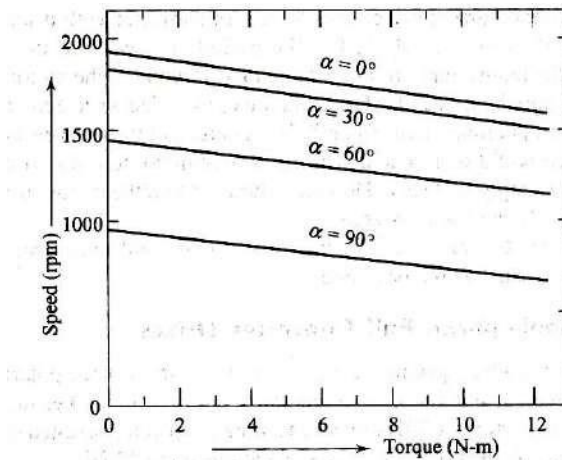

Fig: Torque Speed characteristics of a separately excited DC motor Connected to a single Phase semi controlled drive

Single Phase Full Converter Drive feeding a Separately Excited DC Motor:

A full converter is a two quadrant converter in which the output voltage can be bipolar but the current will be unidirectional since the Thyristors are unidirectional. A full converter feeding a separately excited DC motor is shown in the figure below.

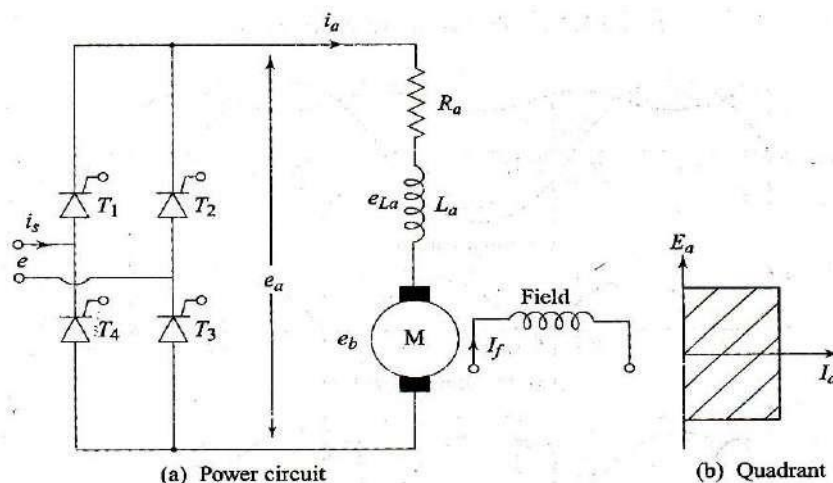

Fig: Single Phase full converter feeding a separately excited DC motor

In this all the four devices are thyristors (T1 to T4) connected in a bridge configuration as shown in the figure.

The operation of the Full converter shown in the figure above is explained with the help of the waveforms shown below.

Thyristors T1 and T3 are simultaneously triggered at a firing angle of α and thyristors T2 and T4 are triggered at firing angle $(\pi + \alpha)$. The voltage and current waveforms under continuous current mode are shown in the figure below. Figure shows the input voltage e and the voltage e_{La} across the inductance (shaded area). The triggering points of the thyristors are also shown in the figure.

As can be seen from the waveforms, the motor is always connected through the thyristors to the input supply. Thyristors T1 and T3 conduct during the interval $\alpha < \omega t < (\pi + \alpha)$ and connect the supply to the motor. From $(\pi + \alpha)$ to α thyristors T2 and T4 conduct and connect the supply to the motor. At $(\pi + \alpha)$ when the thyristors T2 and T4 are triggered, immediately the supply voltage which is negative appears across the Thyristors T1 and T3 as reverse bias and switches them off. This is called natural or line commutation. The motor current i_a which was flowing from the supply through T1 and T3 is now transferred to T2 and T4. During α to π energy flows from the input supply to the motor (both e & i_s and e_a & i_a are positive signifying positive power flow). However during the period π to $(\pi + \alpha)$ some of the motor energy is fed back to the input system. (e & i_s and similarly e_a & i_a have opposite polarities signifying reverse power flow)

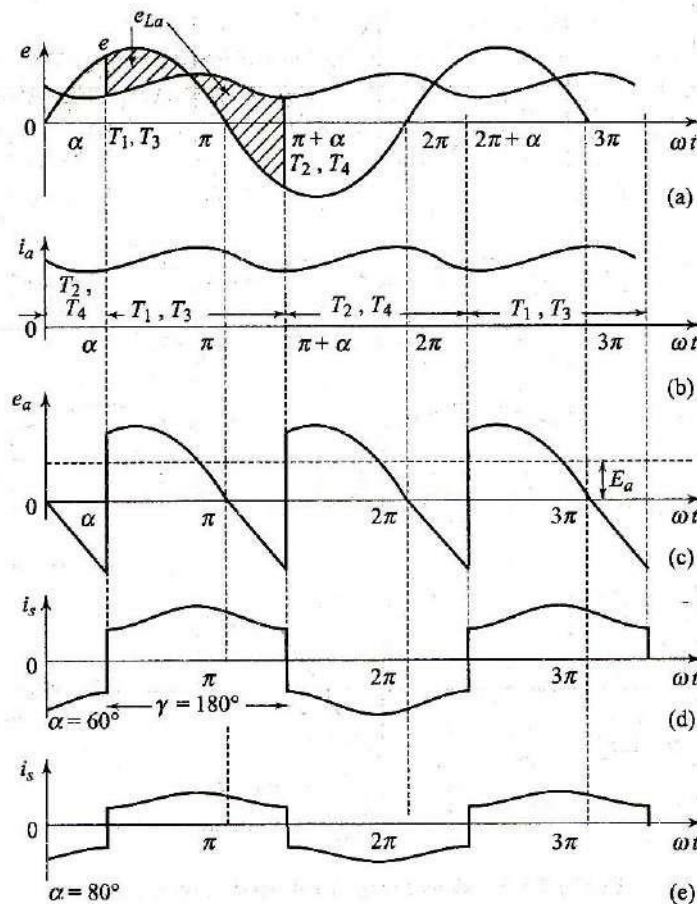

Fig: Voltage and Current waveforms for Continuous current operation in a single Phase fully controlled drive connected to a separately excited DC motor.

Torque Speed Characteristics of a DC separately excited motor connected to a Single phase Full converter:

Assuming motor current to be continuous, the motor armature voltage as derived above for the single phase full converter is given by:

$$E_{dc} = \frac{1}{\pi} \int_{\alpha}^{\pi+\alpha} E_m \sin \omega t \, d(\omega t) = \frac{E_m}{\pi} [-\cos \omega t]_{\alpha}^{\pi+\alpha}$$

$$= \frac{E_m}{\pi} [\cos \alpha - \cos (\pi + \alpha)] \quad E_{dc} = \frac{2 E_m}{\pi} \cos \alpha$$

i.e. $E_a(\alpha) = (2E_m/\pi)(\cos \alpha)$

In terms of average voltages, KVL around the motor armature gives

$$E_a(\alpha) = E_b + I_a R_a = K_a \phi \cdot N + I_a R_a$$

And therefore the average speed is given by :

$$\omega = [E_a(\alpha) - I_a R_a] / K_a \phi.$$

In a separately excited DC motor:

$$T = I_a \cdot K_a \cdot \phi.$$

And applying this relationship along with the above value of $E_a(\alpha)$ for the full converter in the above expression for the speed we get :

$$\omega = [(2E_m/\pi)(\cos \alpha) - I_a R_a] / K_a \phi.$$

$$\omega = [(2E_m/\pi)(\cos \alpha) / K_a \phi] - [I_a R_a / K_a \phi]$$

$$\omega = [(2E_m/\pi)(\cos \alpha) / K_a \phi] - [T \cdot R_a / (K_a \phi)^2]$$

The no-load speed of the motor is given by :

$$\omega_{NL} = [(2E_m/\pi)(\cos \alpha) / K_a \phi] \text{ where the torque } T = 0$$

The resulting torque speed characteristics are shown in the figure below.

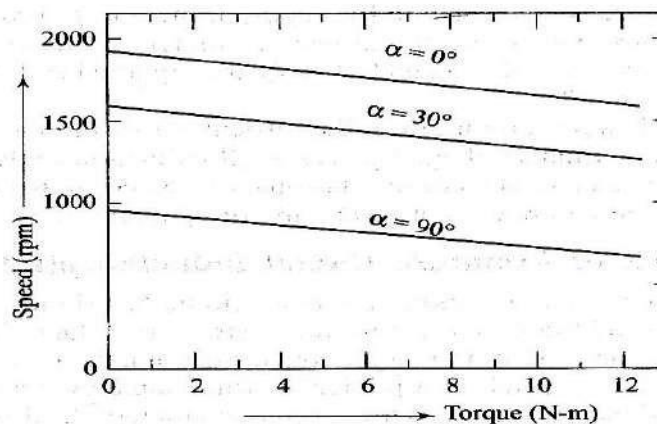

**Fig: Torque Speed characteristics of separately excited DC motor
Connected to a single Phase fully controlled drive at different firing
angles.**

Single Phase Converter Drives for DC Series Motors:

Figure below shows the scheme of a basic single phase speed control circuit connected to a DC series motor. As shown the field circuit is connected in series with the armature and the motor terminal voltage is controlled by a semi or a full converter.

- *Series motors are particularly suitable for applications that require a high starting torque such as cranes hoists, elevators, vehicles etc.*
- *Inherently series motors can provide constant power and are therefore particularly suitable for traction drives.*
- *Speed control is very difficult with the series motor because any change in load current will immediately reflect in the speed change and hence for all speed control requirements separately excited motors will be used.*

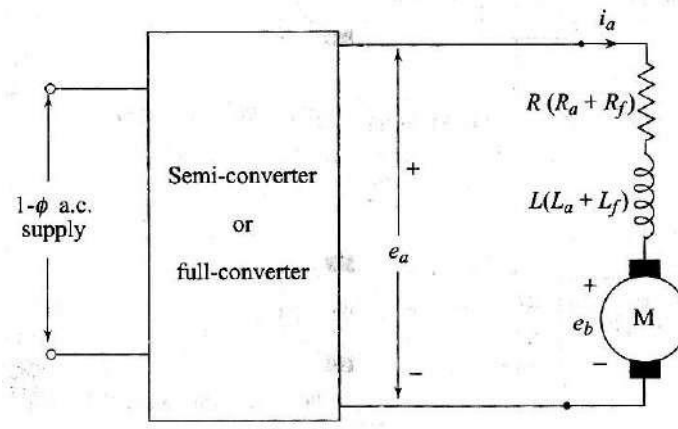

Fig: DC Series motor Power circuit

In the figure the armature resistance R_a and Inductance L_a are shown along with the field resistance and inductance. The basic DC series motor equations are given below again for ease of reference

- $E_b = K_a \cdot \Phi \cdot \omega = K_a \cdot K_f \cdot I_a \cdot \omega$ (since $\Phi = K_f \cdot I_f = K_f \cdot I_a$)
= $K_{af} \cdot I_a \cdot \omega$ (where $K_{af} = K_a \cdot K_f$)

- $T = K_a \cdot \Phi \cdot I_a = K_{af} K_f \cdot I^2 = K_{af} I^2$
- $E_a = E_b + I_a \cdot R_a$
- $\omega = E_a / (K_{af} \cdot I_a) \text{ -- } (R_a / K_{af})$
- $\omega = \sqrt{E_a / (K_{af} \cdot T)} \text{ -- } [R_a / (K_{af})]$

Single Phase Semi Converter Drive connected to DC Series Motors:

The figure below shows the power circuit of a single phase semi converter controlled DC series motor.

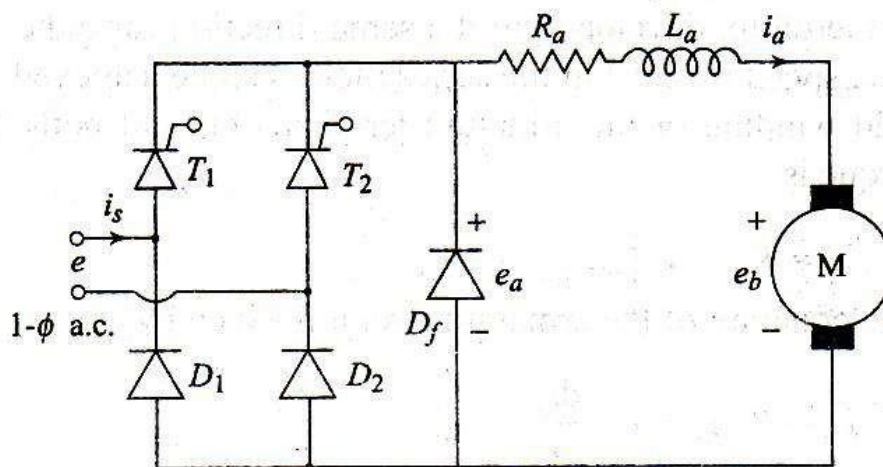

Fig: Power circuit of a Series motor connected to a Semi Controlled converter

Current and voltage waveforms for continuous motor armature current are shown in the figure below. When SCR is triggered at a firing angle α the current flows during the period α to $(\pi + \alpha)$ for continuous conduction.

In separately excited motors a large Back EMF is always present even when the armature current is absent. This back EMF E_b tends to oppose the motor current and so the motor current decays rapidly. This leads to discontinuous motor current over a wide range of operations. Whereas in series motors the back EMF is proportional to the armature current and so E_b decreases as I_a decreases. So the motor current tends to be continuous over a wide range of operations. Only at

high speed and low current is the motor current is likely to become discontinuous. Like in earlier semi converters Freewheeling diode is connected across the converter output as shown in the figure above. Freewheeling action takes place during the interval π to $(\pi + \alpha)$ in continuous current operation.

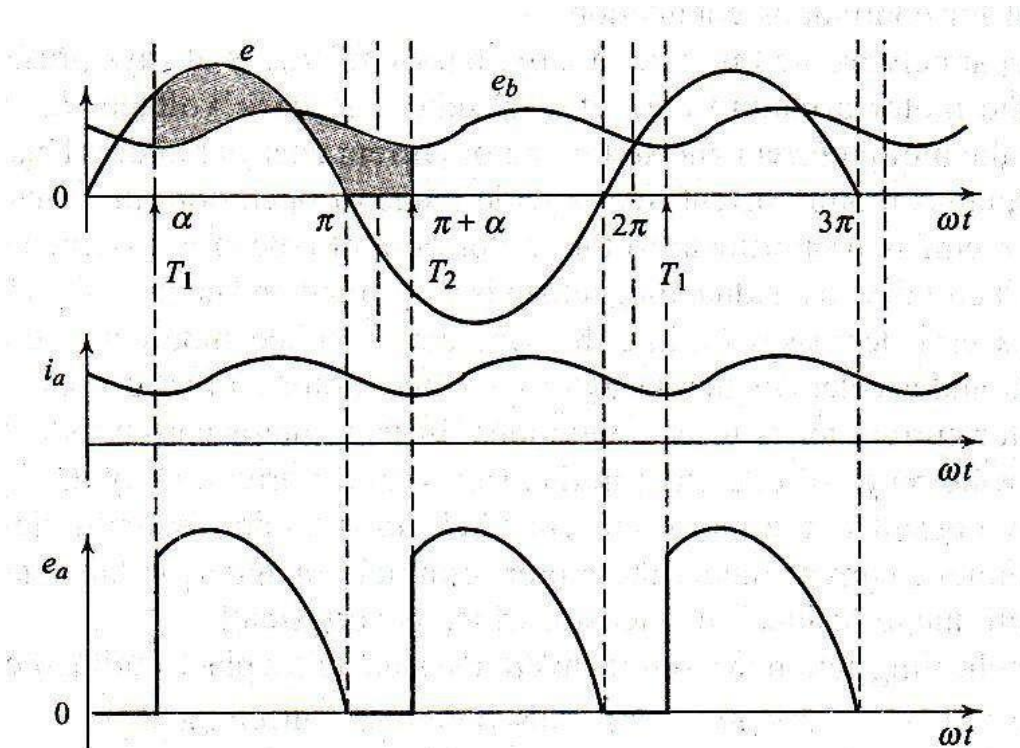

Fig: DC Series motor Semi Converter waveforms in continuous current operation.

In phase controlled converters for Series motors, the current is mostly continuous and the motor terminal voltage can be written as

$$\begin{aligned} E_a &= E_m/\pi (1 + \cos \alpha) = I_a R_a + E_b \\ &= I_a R_a + K_{af} \cdot I_a \cdot \omega \end{aligned}$$

Hence from the above equation the average speed can be written as

$$\omega = [(E_m/\pi)(1 + \cos \alpha) / (K_{af} \cdot I_a)] - [(R_a \cdot I_a / K_{af} \cdot I_a)]$$

$$\omega = [(E_m/\pi)(1+\cos\alpha)/\sqrt{(K_{af}.T)}] - [(R_a/ K_{af})]$$

The torque Speed characteristics under the assumption of continuous and ripplefree current flow are shown in the figure below for different firing angles α .

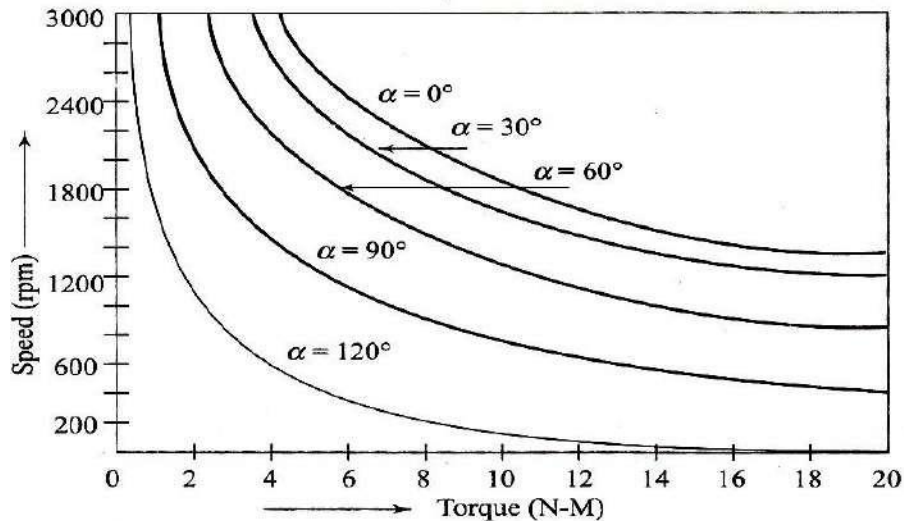

Fig: Torque Speed Characteristics of a DC Series motor controlled by a Single phase Semi converter

Single Phase full converter drive connected to a DC series motor:

The figure below shows the power circuit of a single phase Fully controlled converter connected to a DC series motor.

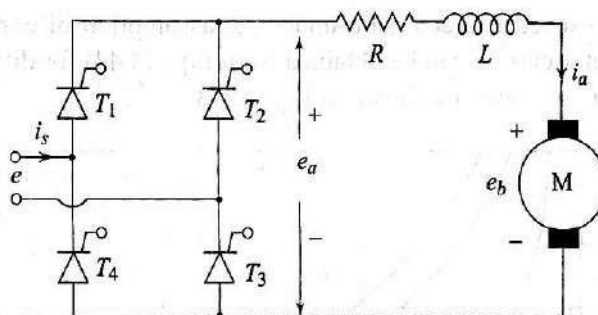

Fig: Power circuit of a Series motor connected to a fully controlled converter

Thyristors T1 & T3 are simultaneously triggered at α and T2 & T4 are simultaneously triggered at $(\pi + \alpha)$. Current and voltage waveforms for continuous motor armature current are shown in the figure below. When SCR is triggered at a firing angle α the current flows during the period α to $(\pi + \alpha)$ for continuous conduction.

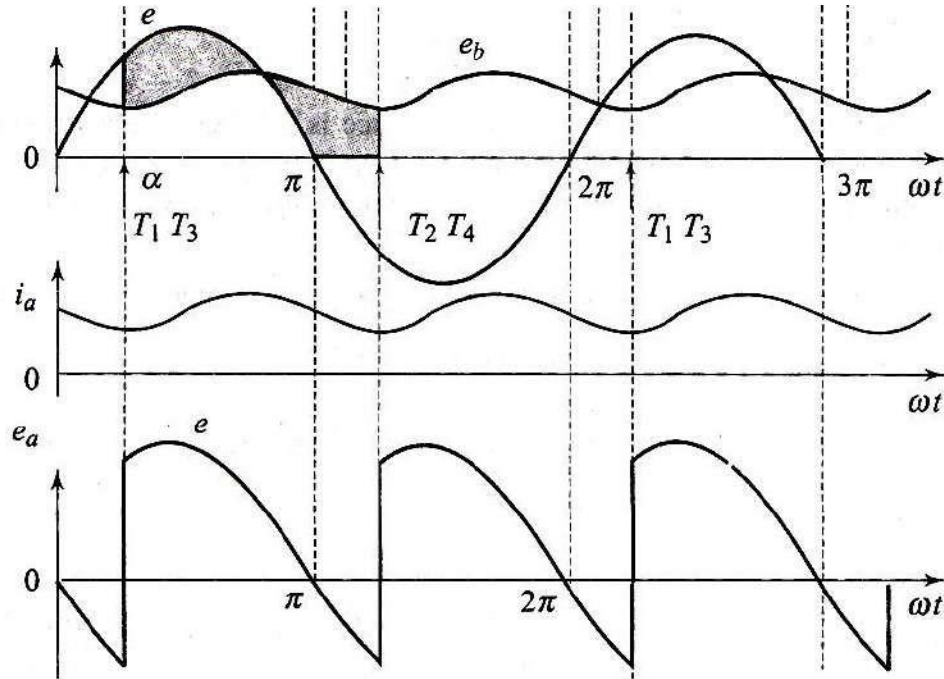

Fig: DC Series motor Full converter waveforms in continuous current operation.

The motor terminal voltage can be written as

$$\begin{aligned} E_a &= 2E_m/\pi (\cos \alpha) = I_a R_a + E_b \\ &= I_a R_a + K_{af} \cdot I_a \cdot \omega \end{aligned}$$

Hence from the above equation the expression for average speed can be written as

$$\omega = \frac{2E_m/\pi (\cos \alpha)}{K_{af} \cdot I_a} - \left[\frac{R_a \cdot I_a}{K_{af} \cdot I_a} \right]$$

$$\omega = \frac{2E_m}{\pi} \cos\alpha / \sqrt{K_{af} T} \quad \text{--} \quad [(R_a / K_{af})]$$

The torque Speed characteristics under the assumption of continuous and ripple free current flow are shown in the figure below for different firing angles α .

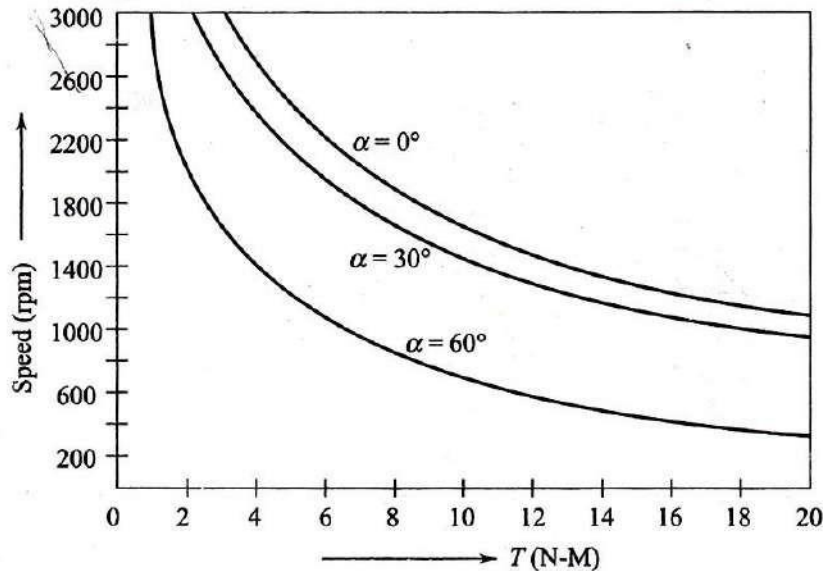

Fig: Torque Speed characteristics of a Series motor connected to a fully controlled converter

Summary:

Important conclusions and concepts:

- In single phase converters output ripple frequency is 100 Hz.(both semi and full)
- Semi converters are one quadrant converters. i.e. they have one polarity of voltage and current at the DC terminals. In this as firing angle varies from 0 to 180° DC output varies from maximum $(2E_m/\pi)$ to zero.
- A full converter is a two quadrant converter in which the output voltage can be bipolar but the current will be unidirectional since the thyristors are

Unidirectional. In this as firing angle varies from 0 to 180° DC output varies from maximum ($2E_m/\pi$) to ($-2E_m/\pi$)

- Separately excited motors are mostly used in applications where good speed regulation and adjustable speed are required.
- Series motors are suitable for applications requiring high starting torque and heavy overloads.
- In case of series motors, Since Torque is proportional to square of the armature current, for a given increase in load torque the increase in armature current is less as compared to separately excited motors where torque is proportional to only armature current.
- There are two basic methods of speed control. Armature Voltage Control and Flux Control.
- AVC is used for speeds below base speeds and FC for speeds above base speed.
- Due to the maximum torque and power limitations DC Drives operating
 - With full field , AVC below base speed can deliver a maximum constant torque and
 - With rated Armature Voltage, Flux control above base speed can deliver a maximum constant power.
- AVC is achieved by Single and three phase Semi & Full converters.
- FC in separately excited motors is obtained by varying the voltage across the field winding and in series motors by varying the number of turns in the field winding or by connecting a diverting resistance across the field winding.

Important formulae and equations:

- *The basic DC motor equations :*
 - The internal voltage generated in a DC motor is given by: $E_b = K_a \cdot \Phi \cdot \omega$
 - The internal Torque generated in a DC motor is given by: $T = K_a \cdot \Phi \cdot I_a$
 - KVL around the armature circuit is given by : $E_a = E + I_a \cdot R_a$
- *Torque speed relations in semi converter:*

o DC separately excited motor:

$$\omega = [(E_m/\pi)(1+\cos \alpha) / K_a\phi - [R_a/(K_a\phi)^2]\tau$$

o DC series motor :

$$\omega = [(E_m/\pi)(1+\cos\alpha)/\sqrt{(K_{af}\cdot T)}] - [(R_a/ K_{af})]$$

• *Torque speed relations in Full converter:*

o DC separately excited motor:

$$\omega = [(2E_m/\pi)(\cos \alpha) / K_a\phi] - [R_a/(K_a\phi)^2]\tau$$

o DC series Motor :

$$\omega = [(2E_m/\pi)(\cos\alpha)/\sqrt{(K_{af}\cdot T)}] - [(R_a/ K_{af})]$$

Illustrative Examples:

Example-1: A separately excited d.c . motor is fed from a 230 V, 50 Hz supply via a single-phase , half –controlled bridge rectifier. Armature parameters are: inductance 0.06 H, resistance 0.3 Ω , the motor voltage constant is $K_a = 0.9$ V/A rad/s and the field resistance is $R_F = 104 \Omega$. The field current is also controlled by semi converter and is set to the maximum possible value. The load torque is $T_L = 50$ N-m at 800 rpm. The inductances of the armature and field circuits are sufficient enough to make the armature and field current continuous and ripple free. Compute : (i) The field current (ii) The firing angle of the converter in the armature circuit

Solution:

(i) First point to be noted is since the units of K_a are V/A rad/sec the basic governing equations for back emf E_b and Torque T will become : $E_b = K_{af} \cdot I_f \cdot \omega$ and $T = K_{af} \cdot I_f \cdot I_a$ where K_{af} is to be taken as the given $K_a = 0.9$ V/A rad/s

(ii) For single-phase semi converter controlled d.c. drive, we can write the expression for field supply voltage as

$$E_f = \frac{Em}{\pi} (1 + \cos \alpha)$$

So , the maximum field voltage and current are obtained when firing angle $\alpha = 0$.

i.e. $E_f = \frac{2Em}{\pi}$

Hence Field voltage $E_f = \frac{2Em}{\pi} = \frac{2 \times \sqrt{2} \times 230}{\pi} = 207.07$ V.

And field current $I_f = \frac{E_f}{R_f} = \frac{207.07}{104} = 1.99$ A

(iii) Now, we can first find out armature current from the relation

$$I_a = \frac{T}{K \frac{\phi}{I_f}} = \frac{50}{0.9 \times 1.99} = 27.92$$
 A

And then back emf from the relation: $E_b = K_a \omega I_f = 0.9 \times (800 \times \frac{2}{60}) \times 1.99 =$
 \times

150.04 V.

Hence finally we can find out armature voltage from the relation : $E_a = E_b + I_a R_a$
 $= 150.04 + 27.92 \times 0.3 = 158.42$ V.

But applied armature voltage from a single phase semi converter is given by the equation

$$E_a = \frac{E_m}{\pi} (1 + \cos \alpha) \text{ and equating this to the above required armature}$$

voltage of 158.42 we get

$$\frac{\sqrt{2}}{2 \times 230} (1 + \cos \alpha) = 158.42 \text{ from which we get } \alpha = 58^\circ$$

Note: Sometimes all the data given in the problem may not be required to solve the problem. In this problem there is some such data. Identify....

Example-2: The speed of a 10 HP, 210 V, 1000 rpm separately excited D.C. motor is controlled by a single-phase full-converter. The rated motor armature current is 30 A, and the armature resistance is $R_a = 0.25 \Omega$. The a.c. supply voltage is 230 V. The motor voltage constant is $K_a\Phi = 0.172$ V/rpm. Assume that sufficient inductance is present in the armature circuit to make the motor current continuous and ripple free. For a firing angle $\alpha = 45^\circ$, and rated motor armature current, determine: 1) The motor torque 2) Speed of the motor at Rated armature current.

Solution:

(1) *The motor Torque:* can be found out directly by using the relation $T = K_a \Phi I_a$. But the constant $K_a \Phi$ is same in the relations for torque and back emf if it is V/Rad/sec in back emf and N-m/A in torque. But it is given in V/RPM . Hence it is first converted to V/Rad/sec and then used in the expression for torque .

$$\begin{aligned} \text{The units of the } K_a \Phi \text{ (V/Rad/sec)} &= K_a \Phi \text{ (V/RPM)} \times 60/2\pi \\ &= \frac{0.172 \times 60}{2\pi} \text{ V-s/rad} = 1.64 \text{ V-s/rad.} \end{aligned}$$

Rated Motor Torque T_R at rated armature current = $K_a \Phi I_{aR} = 1.64 \times 30 = 49.2$ N-m.

(2) *Speed of the Motor at Rated armature current:* The armature voltage in a fully controlled single phase converter is given by:

$$E_a = \frac{2E_m}{\pi} \cos \alpha = \frac{2\sqrt{2} \times 230}{\pi} \cos 45^\circ = 146.42$$

(The given supply voltage of 230 V is RMS value and it is to be converted into E_m

by multiplying by $\sqrt{2}$)

$$E_b = E_a - I_a R_a = 146.42 - (30 \times 0.25) = 138.92 \text{ V.}$$
$$\text{Speed, } N = \frac{E_b}{K_a \Phi} = \frac{138.92}{0.172} = 807.67 \text{ rpm}$$

(Here $K_a \Phi$ is used directly with the given units of V/RPM so that we can get directly speed N in RPM)

Note: In this problem also all the data given is not used to solve the problem.

Identify....

Module – IV: DC Motor Drives

Characteristics of Motor:

Three types of electric motors generally used for drive purposes. DC, Induction and Synchronous motor.

DC Drives:

Separately Excited Dc motor:

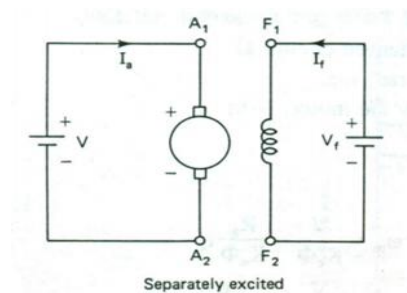

The basic equations for DC motor are

$$E = K_e \phi \omega_m \quad (1.51)$$

$$V = E + I_a R_a \quad (1.52)$$

$$T = K_e \phi I_a \quad (1.53)$$

Where, E = back emf in volt; ϕ = flux per pole in weber; V = supply voltage in volt; I_a = Armature current in Amp; R_a = Armature resistance in ohm; ω_m = speed of armature in rad/sec; T = torque developed in motor in N-mt

From the above set of steady state equations the steady state torque speed relation can be found out as

$$w_m = \frac{V}{K_e \phi} - \frac{I_a R_a}{K_e \phi} \quad (1.54)$$

$$w_m = \frac{V}{K_e \phi} - \frac{R_a T}{(K_e \phi)^2} \quad (1.55)$$

This equation can be applied to all series, shunt, compound and separately excited dc motors.

In the case of separately excited motors, if the field voltage is maintained constant, and assuming the flux as constant, then

$$K_e \phi = K \quad (\text{constant}) \quad (1.56)$$

The speed equation is written for the separately as well as shunt motor is

$$w_m = \frac{V}{K} - \frac{R_a T}{K^2} \quad (1.57)$$

The speed increases from the zero upto the base speed. This method is called the constant torque method. Beyond the rated voltage, and rated armature current the voltage can not be increased further due to insulation problem. So, to control the speed the flux control can be done. By decreasing the flux, speed can be increased above the base speed w_{m0} . This method is called constant power method where both voltage and armature current is kept constants. Further, in the below base speed region, the speed can be decreased from the no load speed w_{m0} by increasing the load. When the load increased, the speed decreased from its no load speed. This motor is used where the speed regulation is good.

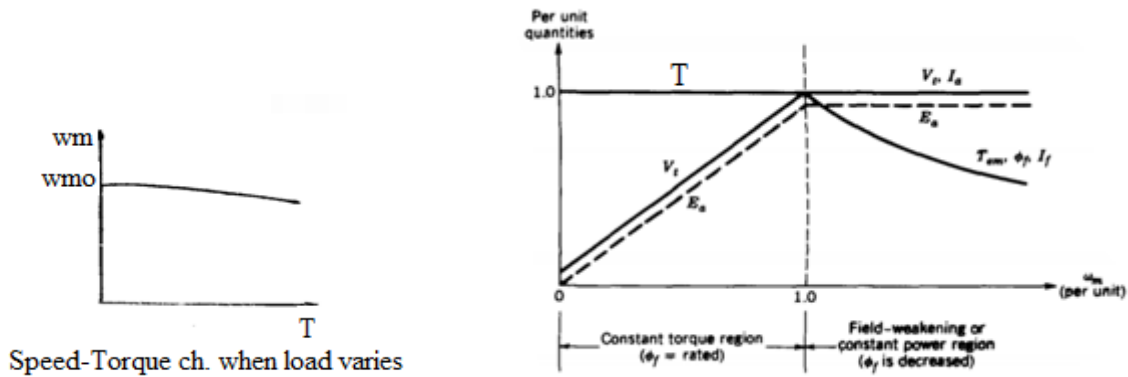

Dc Series Motor:

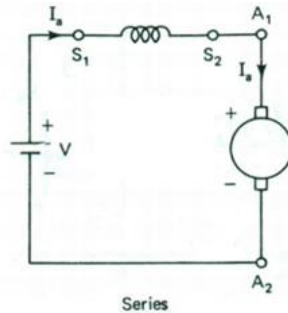

From the basic equation the speed can be written as

$$w_m = \frac{V}{K_e \phi} - \frac{R_a T}{(K_e \phi)^2}$$

In series motor, $T = K_e \phi I_a$, but $\phi \propto I_a$

So, $T = K_e K_f I_a^2$ (1.58)

$$\omega_m = \frac{V}{\sqrt{K_e K_f}} \frac{1}{\sqrt{T}} - \frac{R_a}{K_e K_f} \quad (1.59)$$

In the case of series motor, any increase in torque is accompanied by an increase in the armature current and therefore, an increase in flux. Because the flux increases with torque, the speed must drop to maintain a balance between the induced voltage and the supply voltage. The characteristic is therefore, highly drooping.

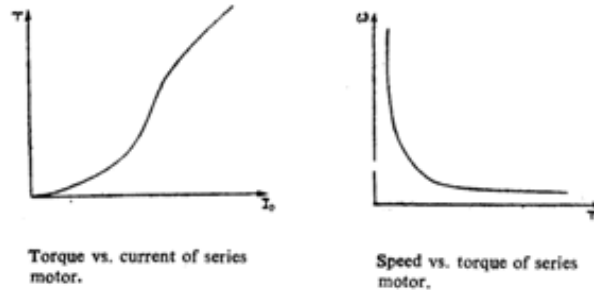

Methods of speed control

From the speed-torque relation from the equation it is seen that, the speed can be controlled by any one of the following three methods.

1. Armature voltage control
2. Armature resistance control (Rheostatic control)
3. Field flux control

Armature voltage control method: (DC shunt motor)

The speeds corresponding to two different armature voltages are V_1 and V_2 of a dc shunt motor are given by

$$\omega_{m1} = \frac{V_1}{K_e \phi} - \frac{R_a T}{(K_e \phi)^2} = \omega_{10} - \Delta \omega \quad (1.60)$$

$$\omega_{m2} = \frac{V_2}{K_e \phi} - \frac{R_a T}{(K_e \phi)^2} = \omega_{20} - \Delta \omega \quad (1.61)$$

The no load speed is directly proportional to the supply voltages. Keeping the load torque as constant, the family of motor torque-speed characteristics can be drawn for a given load torque.

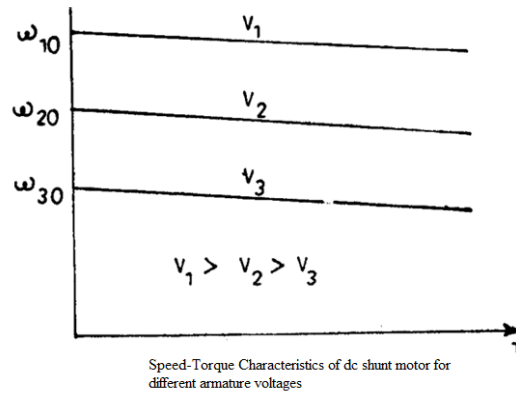

This method is only for below rated speed since the voltage magnitude should not be greater than the rated voltage. The variable voltages can be obtained by phase controlled rectifier and DC-DC Chopper converter.

DC Series motor:

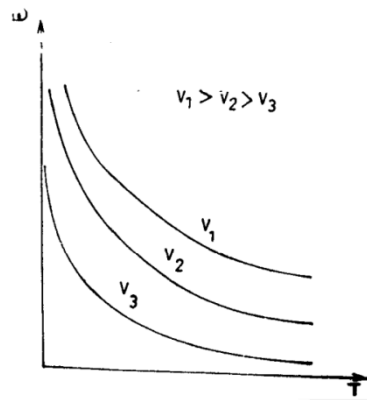

Field flux control method.

If the field of a separately or series excited motor running at a speed is weakened, its induced emf decreases. Because of low armature resistance, the current increases by an amount much larger than the decrease in the field flux. As a result, in spite of the weakened field, the torque is increased by a large amount, considerably exceeding the load torque. The surplus torque thus available causes the motor to accelerate and the back emf to rise. The motor will finally settle down to a new speed, higher than the previous one, at which the motor torque with the weakened field becomes equal to the load torque. Any attempt to weaken the field by a large amount will cause a dangerous inrush of current. Care should therefore be taken to weaken the field only slowly and gradually.

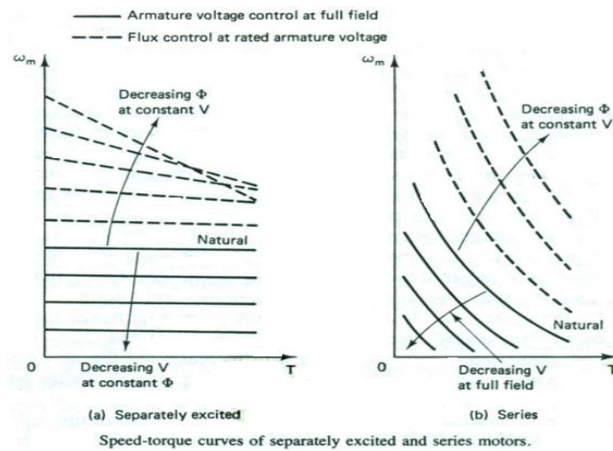

Armature resistance control:

Speed torque characteristics of separately excited (or shunt) and series motors for various values of external resistance R_e in series with the armature are shown.

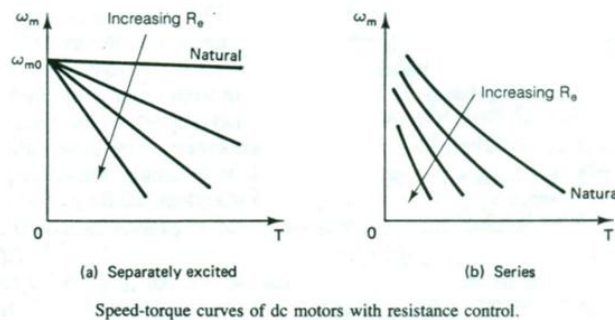

The main drawback of this method of speed control is its poor efficiency. Because of the poor efficiency, this method is seldom used with separately excited motors, except for getting speeds which are required for very short times.

Braking:

There are three methods of braking a dc motor

1. Regenerative braking.
2. Dynamic braking or rheostatic braking.
3. Plugging or reverse voltage braking

Regenerative Braking:

In regenerative braking, the energy generated is supplied to the source.

Separately Excited Motor:

The steady-state equivalent circuit of a separately excited motor and source is given in figure. If by some method the induced emf E is made greater than the source voltage V , the current will reverse. The machine will work as a generator and the source will act as a sink of energy, thus giving regenerative braking.

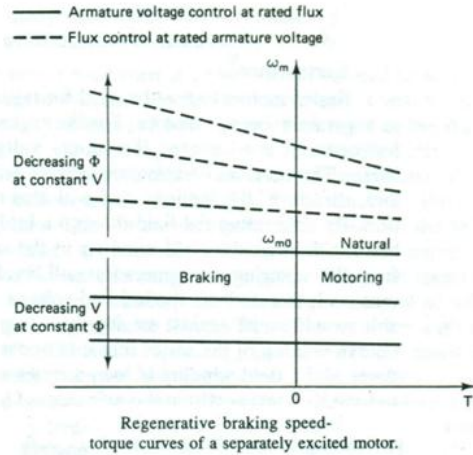

Series motor

Series motors cannot be used for regenerative braking in the same simple way as separately excited motors. For the regenerative braking to take place, the motor induced emf must exceed the supply voltage and the armature current should reverse. The reversal of armature current will reverse the current through the field, and, therefore, the induced emf will also reverse. The main advantage of regenerative braking is that the generated electrical energy is usefully employed instead of being wasted in rheostats as in the case of dynamic braking and plugging.

Dynamic Braking:

The dynamic braking of a dc motor is done by disconnecting it from the source and closing the armature circuit through a suitable resistance. The motor now works as a generator, producing the braking torque. For the braking operation, the separately excited (or shunt) motor can be connected either as a separately excited generator (fig.b), where the flux remains constant, or it can be connected as a self-excited shunt generator, with the field winding in parallel with the armature (fig.c).

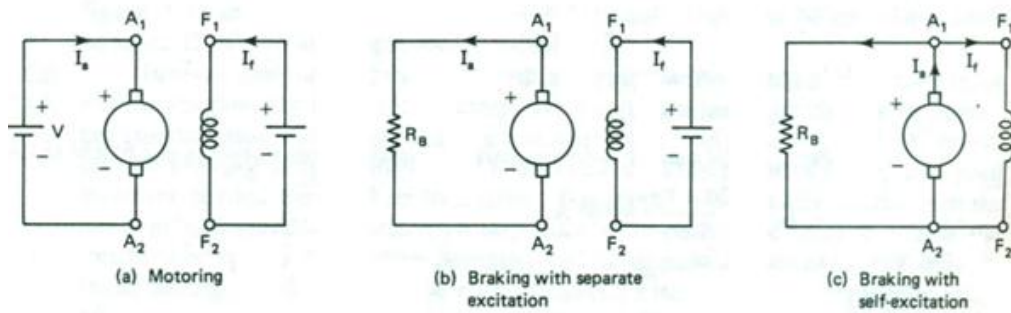

Dynamic braking of separately excited motor.

Series Motor:

For dynamic braking, the series motor is usually connected as a self-excited series generator. For the self-excitation, it is necessary that the current forced through the field winding by the induced emf aids the residual flux. This requirement is satisfied either by reversing the armature terminals or the field terminals.

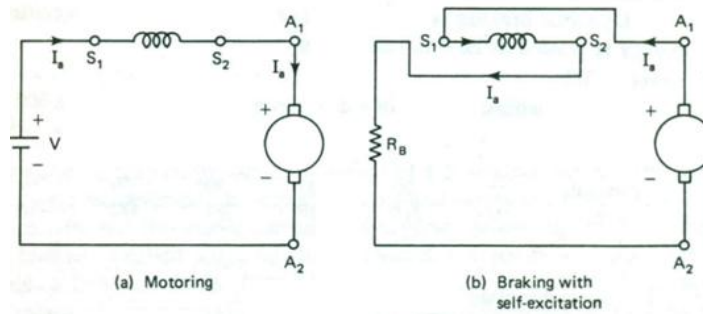

Dynamic braking of series motor.

Speed-Torque Characteristics during dynamic braking:

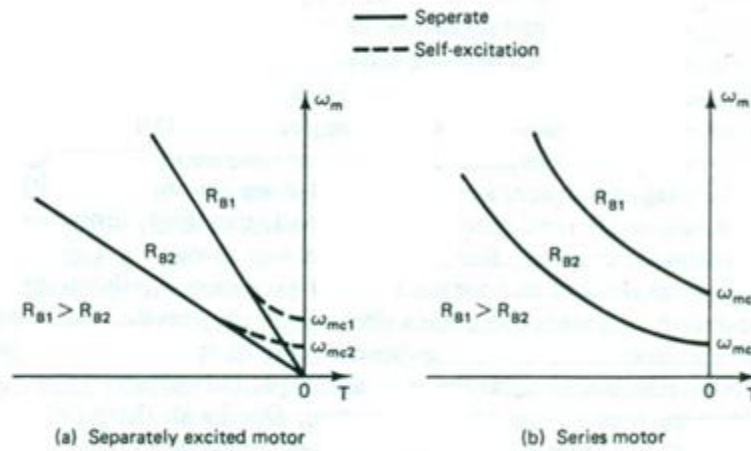

Speed-torque curves of dc motors under dynamic braking.

Plugging:

If the armature terminals (or supply polarity) of a separately excited (or shunt) motor when running are reversed, the supply voltage and the induced voltage will act in the same direction and the motor current will reverse, producing braking torque. This type of braking is called plugging. In the case of a series motor, either the armature terminals or field terminals should be reversed. Reversing of both gives only the normal motoring operation.

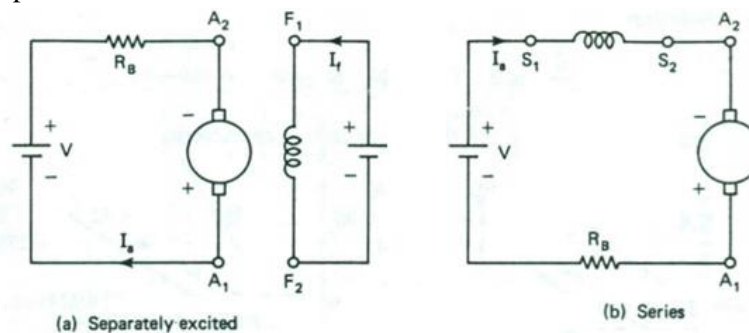

Plugging operation of dc motors.

Torque-speed characteristics:

When running at the rated speed, the induced voltage will be nearly equal to the supply voltage V . Therefore, at the initiation of braking, the total voltage in the armature circuit will be nearly $2V$. To limit the current within the safe value, a resistance equal to twice the starting resistance will be required.

Plugging is a highly inefficient method of braking. Not only is power supplied by the load, but also the power taken from the source is wasted in resistances.

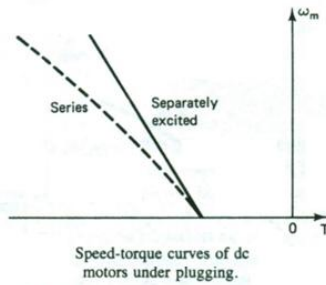

Starting:

Separately excited dc motor:

The maximum current that a dc motor can safely carry during transients of short duration is limited by the maximum armature current that can be commutated without sparking. From the speed equation we see

$$\omega_m = \omega_0 - \Delta\omega$$

For large motors (greater than 10hp), the armature resistance R_a is very small. For these motors, the speed drop $\Delta\omega$ is very small, and the machine is considered to be constant speed machines. The torque developed at starting T_{st} and starting current I_{st} can be calculated by keeping speed as zero during starting.

$$\frac{V}{K\phi} = \frac{R_a I_{st}}{(K\phi)^2} \tag{1.62}$$

$$\Rightarrow T_{st} = (K\phi) \frac{V}{R_a} \tag{1.63}$$

The starting current is $I_{st} = \frac{V}{R_a}$ (1.64)

Effect of reducing source voltage during starting.

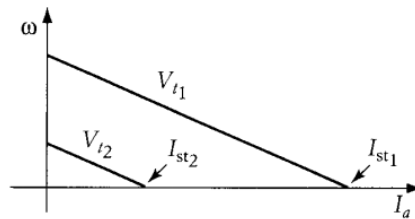

Effect of reducing external resistances.

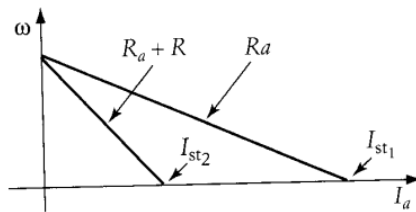

Series Motor:

In series motor, the starting current is less due to presence of field resistances in series with armature resistance.

$$I_{st} = \frac{V}{R_a + R_f} \quad (1.65)$$

$$T_{st} = KC \left(\frac{V}{R_a + R_f} \right)^2 \quad (\text{series motor}) \quad (1.66)$$

$$T_{st} = KC \left(\frac{V}{R_{fsh}} \right) \left(\frac{V}{R_a} \right) \quad (\text{shunt motor}) \quad (1.67)$$

From the two equations it is seen that,

T_{st} is less in shunt motor and more in series motor.

I_{st} is more in shunt motor and less in series motor. So, series motor is widely used in traction drive.

Module – V: Induction Motor Drives:

Advantages

- Light in weight (cage type motor is usually used)
- Higher efficiency
- Low maintainance
- Robust and reliable
- Less cost than commutator type motor
- Ability to operate in dirty and explosive environment
- Advance feedback control technique such as field oriented control

Disadvantages

- Armature and field windings are highly coupled
- Non-linear modeling
- Multi-variable structure
- Controller such as power converter, inverter are relatively complex and expensive.

Steady-state performance of three phase induction motor:

The steady state performance can be studied from the power flow and equivalent circuit.

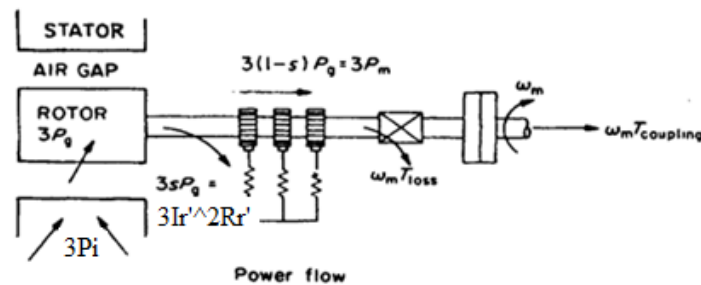

Input power to the stator is $P_i = 3V_s I_s \cos \theta_s$ (1.68)

Input power = stator cu loss+ core loss+ air gap power

$$\text{Stator cu loss } P_{scu} = 3(I_r')^2 R_s \quad (1.69)$$

$$\text{Core loss } P_c = 3 \frac{V_s^2}{R_m} \quad (1.70)$$

$$\text{The air gap power per phase } P_g = (I_r')^2 \frac{R_r'}{s} \quad (1.71)$$

$$\text{Rotor circuit power per phase } (I_r')^2 R_r' = s P_g \quad (1.72)$$

$$\text{Mechanical power } P_m = (1-s) P_g = (1-s) \frac{(I_r')^2 R_r'}{s} \quad (1.73)$$

$$\text{Thus electromagnetic torque is } T_m = \frac{P_m}{\omega_m} = \frac{P_g(1-s)}{\omega_s(1-s)} = \frac{P_g}{\omega_s} = \frac{1}{\omega_s} \frac{(I_r')^2 R_r'}{s} \quad (1.74)$$

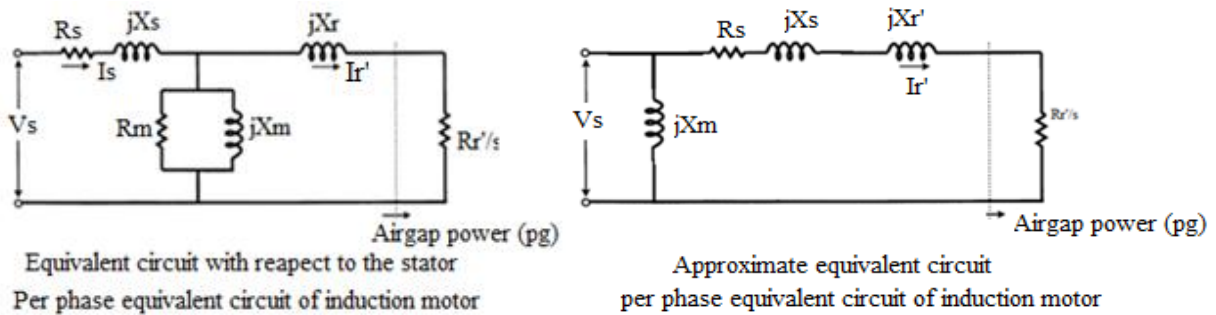

$$\text{But from equivalent circuit } I_r' = \frac{V_s}{\sqrt{(X_s + X_r')^2 + \left(R_s + \frac{R_r'}{s}\right)^2}}$$

$$\text{Hence } T_m = \frac{1}{\omega_s} \frac{V_s^2}{\left(R_s + \frac{R_r'}{s}\right)^2 + (X_s + X_r')^2} * \frac{R_r'}{s} \quad (1.75)$$

Steady-state torque-speed Characteristics:

When the slip is very small, $T_m \propto s$

When the slip is very large $T_m \propto \frac{1}{s}$

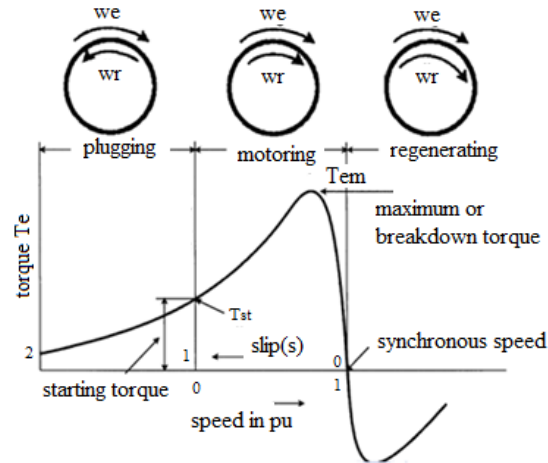

Three zones are there i) motoring zone ($0 < s < 1$) ii) regenerating zone ($s < 0$) iii) plugging zone ($1 < s < 2$)

In the normal motoring zone $T_m = 0$ at $s = 0$. When slip increases, speed decreases but torque approaches maximum value. In the breakdown zone called quasi region, the stator drop is small and flux remains constant.

Features

- At $s = 0, T_m = 0$. Because there is no induced current and zero relative speed
- T_m is the maximum at s_m where $R'_r = sX'_r$
- T_{st} is starting torque when $s = 1$
- The motor is stable between (0 to s_m)

Four-quadrant operation of Induction motor :

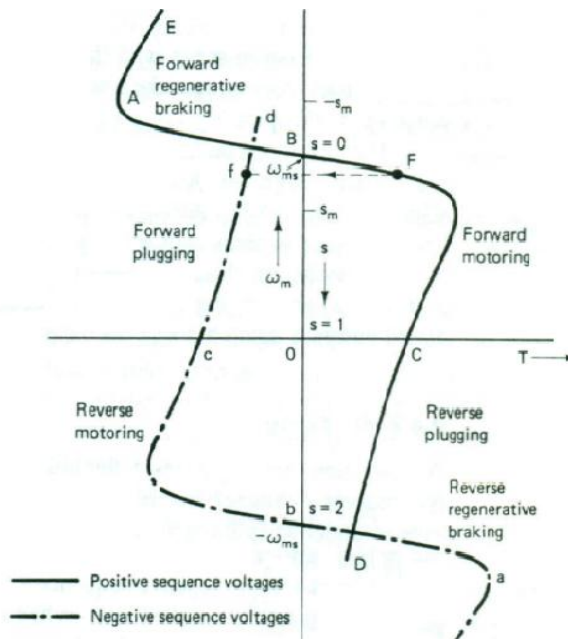

Speed-Control

There are five methods for speed control for modifying speed-torque characteristics. **i)** Stator voltage control **ii)** Stator Frequency control **iii)** Slip power recovery control ((Kramer drive)) or Rotor emf injection method **iv)** Rotor resistance control

Last two methods are only for slip ring induction motor.

Supply voltage control Method

$$T_m \propto V_s^2$$

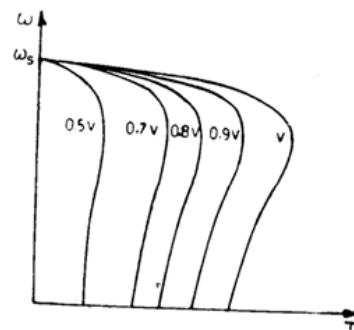
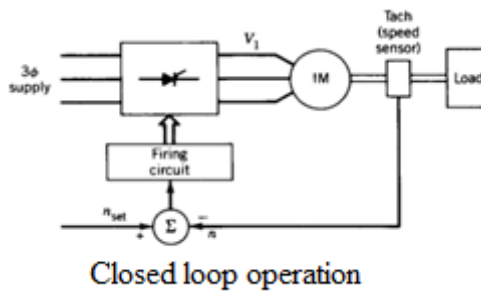
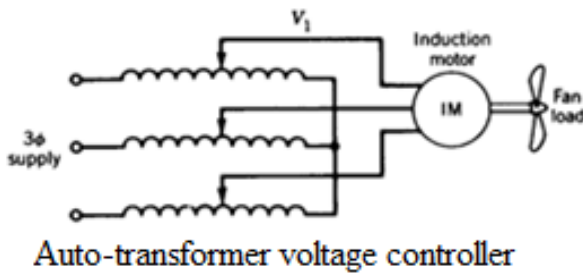

Speed-torque characteristics with voltage control

The curves indicate that the slip at maximum torque is independent of terminal voltages. The range of speeds within which steady state operation (for constant torque loads) may take place is the same for all voltages i.e. between the maximum torque and synchronous speed. Within that region there will be a small speed drop with decrease in voltage. This method is suitable for fan, pump and centrifugal drives.

Drawbacks:

- Gives poor energy efficiency at low speed
- This method is only suitable for below base speed

Stator Frequency control

By controlling the stator frequency 'f', synchronous speed which in turn determines the rotor speed of the motor. When the frequency is varied, then the magnetizing current I_m is also affected, which is given by

$$I_m = \frac{V_s}{X_m} = \frac{V_s}{2\pi f I_m} \quad (1.76)$$

But, the magnetizing current must be constant for constant breakdown torque (maximum torque). Therefore, for constant breakdown torque, $\frac{V_s}{f}$ ratio should be maintained constant. When the operating frequency is increased beyond the breakdown torque, then the torque gets reduced but the starting torque is increased. For further decrease in supply frequency $\frac{V_s}{f}$ can not be maintained constant. At very low frequency the apparent impedance increases that increased the voltage drop. Hence V_s decreased.

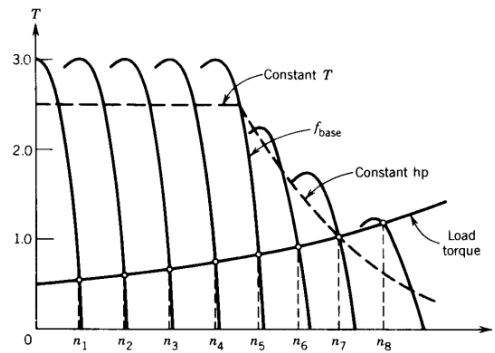
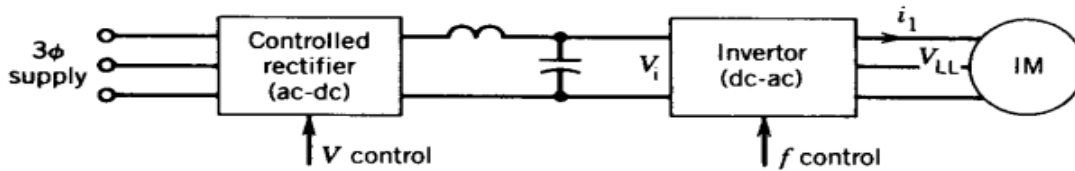

Slip power recovery control (rotor emf injection method):

In an induction motor, torque is equal to the power crossing the air gap divided by the synchronous mechanical speed. In early slip-ring induction motor drives, power was transferred through the motor to be dissipated in external resistances, connected to the slip-ring terminals of the rotor. This resulted in an inefficient drive over most of the speed range. More modern slip-ring drives use an inverter to recover the power called slip power from the rotor circuit, feeding it back to the supply system. One of the best recovery drive circuit is static Scherbius drive.

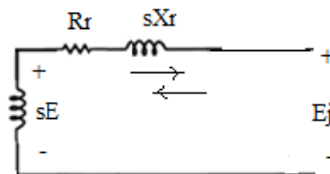

motor operation with injection voltage (E_j) in rotor

At running condition of slip with constant load, voltage and frequency the rotor current

$$I_r = \frac{sE}{\sqrt{(R_r^2 + (sX_r)^2)}} \quad \text{For slip to be very small, } R_r^2 \geq (sX_r)^2$$

$$I_r = \frac{sE}{R_r} \quad (1.77)$$

By giving additional voltage E_j at the rotor end, then $I_r = \frac{s_j E - E_j}{R_r}$, (1.78)

Since the load torque is constant, then

$$\frac{sE}{R_r} = \frac{s_j E - E_j}{R_r}$$

$$\Rightarrow s_j = s + \frac{E_j}{E} \quad (1.79)$$

It is seen the slip increases when the injected emf is in phase opposition to the induced emf. Now, as the slip increases, the induced emf increases and hence the current till the developed torque is equal to the load torque. In this way the injected emf controls the speed. Similarly when the injected emf is in same phase then the slip decreases.

$$s_j = s - \frac{E_j}{E} \quad (1.80)$$

This slip in term of slip power in rotor circuit can be recovered and send back to ac supply by Scherbius drive and efficient thus increase.

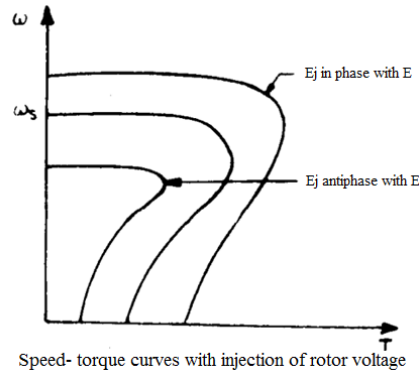

Scherbius method for slip power recovery

In this scheme, the rotor terminals are connected to a three-phase diode bridge that rectifies the rotor voltage. This rotor output is then inverted into mains frequency ac by a fully controlled thyristor converter operating off the same mains as the motor stator. The dc link current, smoothed by a reactor, may be regulated by controlling the firing angle of the converter in order to maintain the developed torque at the level required by the load. The current controller (CC) and speed controller (SC) are also indicated. The current controller output determines the converter firing angle α from the firing control circuit (FCC).

From the equivalent circuit and ignoring the stator impedance, the RMS voltage per phase in the rotor circuit is given by

$$V_R = \frac{V_s}{n} \frac{\omega_r}{\omega_s} = \frac{V_s}{n} \frac{s\omega_s}{\omega_s} = \frac{sV_s}{n} \quad (1.81)$$

Where ω_r and ω_s are the angular frequencies of rotor and stator voltages respectively. And 'n' is the ratio of the equivalent stator to rotor turns. The dc-link voltage at the rectifier terminals of the rotor, v_d is

$$\text{given by } v_d = \frac{3\sqrt{6}}{\pi} V_R \quad (1.82)$$

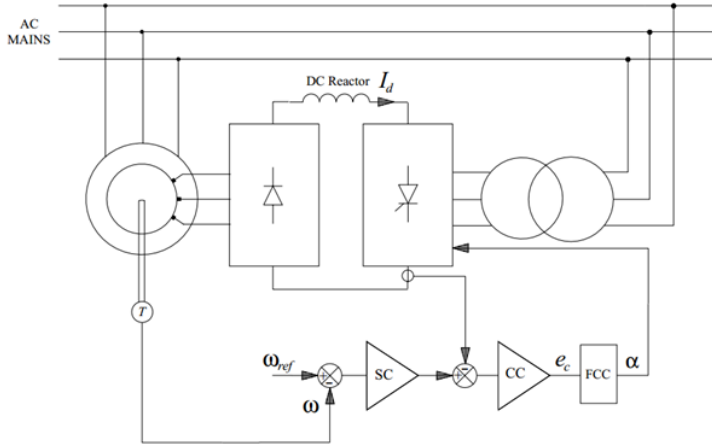

Static Scherbius scheme of slip power control

Assuming that the transformer interposed between the inverter output and the ac supply has the same turn ratio 'n' as the effective stator-to-rotor turns of the motor.

$$v_d = -\frac{3\sqrt{6}}{\pi} \frac{V_s}{n} \cos \alpha \quad (1.83)$$

The negative sign arises because the thyristor converter develops negative dc voltage in the inverter mode of operation. The dc-link inductor is mainly to ensure continuous current through the converter so that the expression (1.83) holds for all conditions of operation. Combining the preceding three equations gives

$$s\omega_s = -\omega_s \cos \alpha \quad \text{so that} \quad s = -n \cos \alpha \quad (1.84)$$

And the rotor speed is

$$\omega_0 = \frac{1}{P}(1-s)\omega_s = \frac{1}{P}\omega_s(1+n \cos \alpha) \text{ rad/sec} \quad (1.85)$$

Thus, the motor speed can be controlled by adjusting the firing angle α . By varying α between 180° and 90° , the speed of the motor can be varied from zero to full speed, respectively.

Rotor resistance control

The introduction of rotor resistance in slip ring induction motor will modify the speed-torque curves. The operating points from zero to synchronous speed can be obtained in this method.

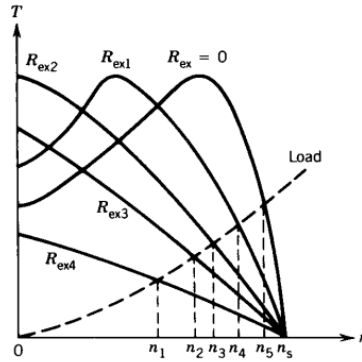
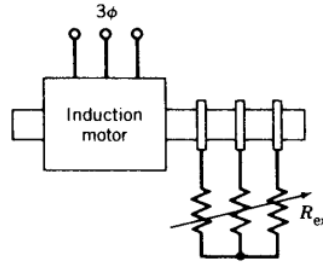

Braking:

Regenerative braking

The speed-torque curves obtained by the reversal of the phase sequence of the motor terminal voltages are also shown by dotted lines. With a positive sequence voltage across the motor terminals, the operation above synchronous speed gives the regenerative braking operation (portion BAE). Similarly, with a negative sequence voltage across the motor terminals, regenerative braking is obtained for speeds above the synchronous speed in the reverse direction (portion bae). In regenerative braking, the motor works as an induction generator, converting mechanical energy supplied by the load to electrical energy, which is fed to the source. Thus the generated energy is usefully employed.

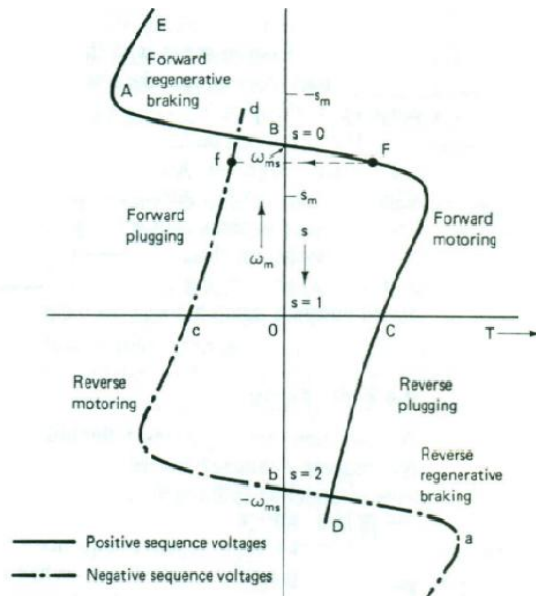

Plugging

An induction motor operates in the plugging mode for slips greater than 1. For positive sequence voltages, a slip greater than 1 is obtained when the rotor moves in the reverse direction (portion CD). Since the motor is running in the reverse direction, a positive torque provides the braking operation. With negative sequence voltages, plugging takes place on portion cd, shown by the chain-dotted line. When running in the forward direction, the motor can be braked by changing the phase sequence of the motor terminal voltages by simply interchanging the connections of any two motor terminals. This will transfer the operation from point F to f and braking will commence. The motor torque is not zero at zero speed. When braked for stopping, the motor should be disconnected from the supply at or near zero speed. An additional device will be required for detecting zero speed and disconnecting the motor from the supply. Therefore, plugging is not suitable for stopping. It is, however, quite suitable for reversing the motor. From the forward motoring (portion BC), the reverse plugging operation (portion CD) is obtained when an active load drives the motor in the reverse direction, as in crane and hoist applications. When operating this way, plugging is sometimes called counter-torque braking.

Dynamic braking

In dc dynamic braking, the motor is disconnected from the ac supply and connected to a dc supply. The flow of direct current through the stator windings sets up a stationary magnetic field. The relative speed between the stationary stator field and the moving rotor is now negative. Consequently, 3-phase voltages of reverse polarity and phase sequence (compared to the motoring in the same direction) are induced in the rotor. The resultant three-phase rotor currents produce a rotating field, moving at the rotor speed in the direction opposite to that of rotor, thus giving a stationary rotor field. Since both stator and rotor fields are stationary and rotor current flows in the reverse direction, a steady braking torque is produced at all speeds. It, however, becomes zero at standstill due to zero rotor currents.

Synchronous motor

In the synchronous motor, the stator windings are exactly the same as in the induction motor, so when connected to the 3-phase supply, a rotating magnetic field is produced. But instead of having a cylindrical rotor with a cage winding, the synchronous motor has a rotor with either a d.c. excited winding (supplied via slip rings), or permanent magnets, designed to cause the rotor to 'lock-on' or 'synchronise with' the rotating magnetic field produced by the stator. Once the rotor is synchronised, it will run at exactly the

same speed as the rotating field despite load variation, so under constant-frequency operation the speed will remain constant as long as the supply frequency is stable.

With the synchronous machine we again find that, the maximum (pull-out) torque which can be developed before the rotor is forced out of synchronism with the rotating field. This 'pull-out' torque will typically be 1.5 times the continuous rated torque, but for all torques below pull-out the steady running speed will be absolutely constant. The torque-speed curve is therefore simply a vertical line at the synchronous speed.. We can see from Figure that the vertical line extends into quadrant 2, which indicates that if we try to force the speed above the synchronous speed the machine will act as a generator.

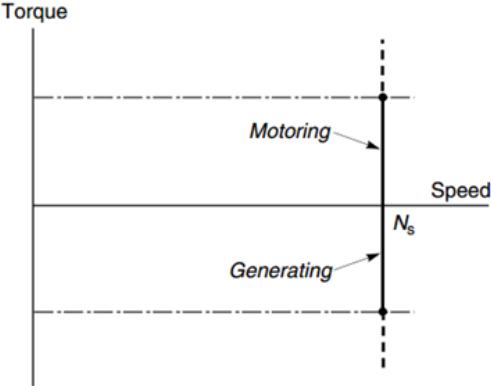

Steady state torque-speed characteristic for Synchronous motor at constant frequency

CONTROL OF DC AND AC DRIVE

Dc motors are widely used in many speed-control drives. Open-loop operation of dc motors may be satisfactory in many applications. When the load increases the speed of the motor drops and the new operating point of speed is obtained after the transient. For getting constant speed i.e. the initial operating point the open loop does not work. So, closed-loop control system is required. The basic block diagram of closed-loop control system is shown.

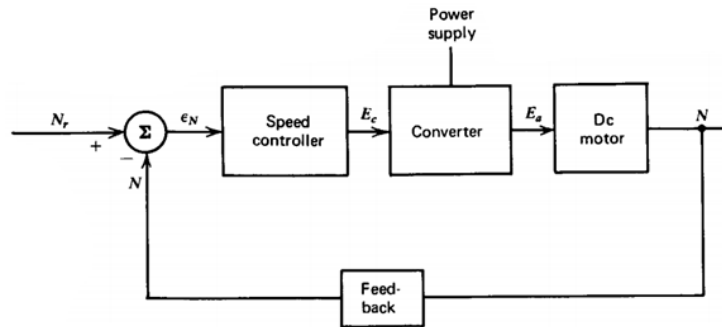

Basic block diagram of a closed-loop speed-control system.

If the motor speed decreases due to application of additional load torque, the speed error ϵ_N increases, which increases the control signal E_c . This in turn changes the firing angle of the converter, and thus increases the motor torque to restore the speed of the drive system. The system passes through a transient period until the developed torque matches the applied torque. A closed-loop system improves the dynamic response specially during acceleration, deceleration and disturbances such as loading in drive system. The response of a closed-loop system can be studied by using transfer function techniques.

Separately Excited DC motor Drives

Armature voltage control is inherently a closed loop control system in dc motor drives. However, the output speed signal can not be measured and the speed error is not found properly. This closed loop is further extended by using a feed back tachogenerator with speed controller and converter for modern control drives.

Motor Transfer function without tachogenerator and converter. (Armature voltage speed control)

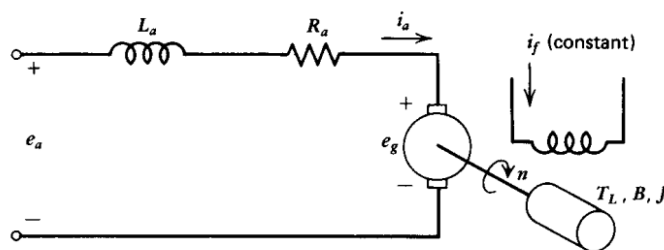

The basic set of equations are

$$e_a = i_a R_a + L_a \frac{di_a}{dt} + e_g \quad (2.1)$$

$$\text{Where } e_g = K_a n \quad (2.2)$$

The torque balance equation is $T_m = T_L + Bn + J \frac{dn}{dt}$ (2.3)

Also $T_m = K_a i_a$ (2.4)

In Laplace domain all time domain equations are brought into frequency domain

$$E_a(s) = I_a(s)R_a + L_a s I_a(s) + E_g(s) \quad (2.5)$$

$$E_g(s) = K_a N(s) \quad (2.6)$$

$$T_m(s) = T_L(s) + BN(s) + JsN(s) \quad (2.7)$$

$$T_m(s) = K_a I_a(s) \quad (2.8)$$

From the eq.(2.5)

$$I_a(s) = \frac{E_a(s) - E_g(s)}{R_a + sL_a} = \frac{[E_a(s) - E_g(s)] * 1/R_a}{1 + s\tau_a} \quad (2.9)$$

where $\tau_a = \frac{L_a}{R_a}$ electrical time constant

From eq.(2.7)

$$N(s) = \frac{T_m(s) - T_L(s)}{B + sJ} = \frac{[T_m(s) - T_L(s)] * 1/B}{1 + s\tau_m} \quad (2.10)$$

where $\tau_m = \frac{J}{B}$ mechanical time constant

The closed loop T.F.is

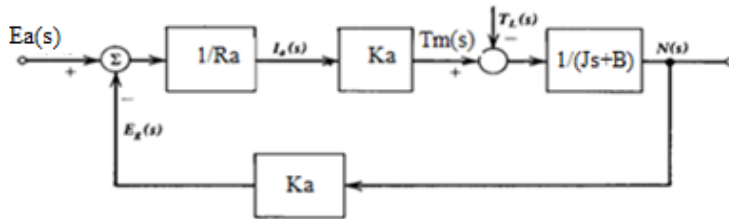

There are two inputs one electrical input voltage E_a and the other mechanical load torque T_L . So, considering, one input at a time neglecting others the total T.F. is coming as

$T_L = 0$ and neglecting L_a

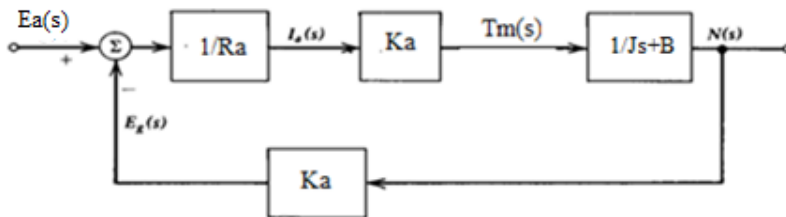

$$\frac{N(s)}{E_a(s)} = \frac{K_m}{1 + s\tau_m} \quad (2.11)$$

Where $K_m = \frac{(K_a / R_a)}{(B + K_a^2 / R_a)}$ motor gain constant and $\tau_m = \frac{J}{B + K_a^2 / R_a}$ mechanical time constant

K_a is called electric friction and $B + K_a^2 / R_a$ called total friction

Letting $E_a(s) = 0$

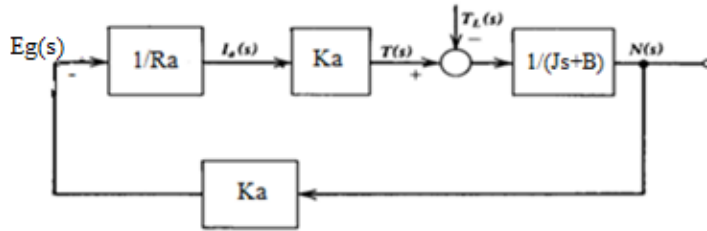

$$\frac{N(s)}{T_L(s)} = \frac{-K}{s\tau_m + 1} \quad (2.12)$$

where $K = \frac{1}{B + K_a^2 / R_a}$

Combining eq.(2.11 and 2.12)

$$N(s) = \frac{K_m}{s\tau_m + 1} E_a(s) - \frac{K}{s\tau_m + 1} T_L(s) \quad (2.13)$$

Neglecting electrical time constant the armature voltage control is said to be first order system.

For the simplicity the T.F. can be represented by neglecting the torque now $\frac{N(s)}{E_a(s)} = \frac{K_m}{s\tau_m + 1}$

Motor Transfer function with tachogenerator and converter. (Armature voltage speed control)

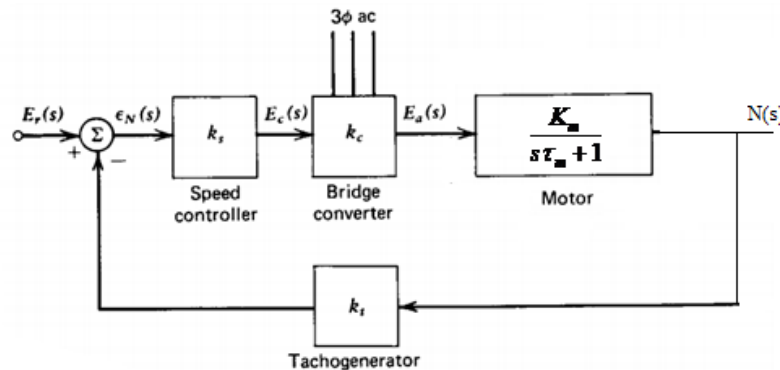

closed-loop speed control

$$\frac{E_a(s)}{E_c(s)} = K_c = \frac{3\sqrt{2}V_{LL}}{\pi\hat{E}_c} \quad (2.14)$$

Where \hat{E}_c corresponds to 0° firing angle and V_{LL} is the ac line to line rms value. The speed controller may be P or PI type can be taken.

Now, the closed loop T.F. can be formed as

$$\frac{N(s)}{E_r(s)} = \frac{G(s)}{1 + G(s)H(s)} \quad (2.15)$$

$$\text{Where } G(s) = \frac{K_s K_c K_m}{1 + s \tau_{m1}} \quad (2.16)$$

$$H(s) = K_t \quad (2.17)$$

$$\text{From the eq (2.15), (2.16), (2.17)} \quad \frac{N(s)}{E_r(s)} = \frac{K_1}{1 + s \tau_1} \quad (2.18)$$

$$\text{Where } K_1 = \frac{K_s K_c K_m}{K_s K_c K_m K_t + 1} \quad \text{and} \quad \tau_1 = \frac{\tau_{m1}}{K_s K_c K_m K_t + 1}$$

Transfer function for field control method:

Some dc drives are operated with field control and with a constant current in the armature circuit. Usually, the armature current is maintained constant using a closed-loop system. Since the armature time constant is very small compared to the field time constant, the response time of the closed-loop system controlling the armature current can be considered zero, and thus the change in the armature current due to the variation of field current and motor speed can be neglected.

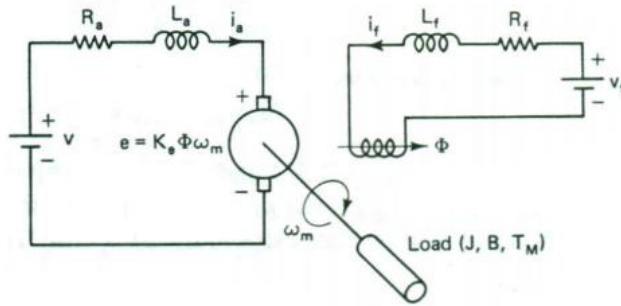

The dynamics for the field control are

$$V_f = i_f R_f + L_f \frac{di_f}{dt} \quad (2.19)$$

Assuming the armature current constant

$$T_m = K_a i_f \quad (2.20)$$

$$T_m = T_L + Bn + J \frac{dn}{dt} \quad (2.21)$$

$$\Rightarrow J \frac{dn}{dt} = T_m - T_L - Bn \Rightarrow J \frac{dn}{dt} = K_a i_f - T_L - Bn$$

Putting the Laplac transformation in those equations we get

$$V_f(s) = I_f(s)R_f + L_f s I_f(s) \Rightarrow I_f(s) = \frac{V_f(s)}{R_f(1 + s \tau_f)} \quad (2.22)$$

$$JsN(s) = K_a I_f(s) - T_L(s) - BN(s) \Rightarrow N(s) = \frac{K_a I_f(s) - T_L(s)}{Js + B}$$

Putting the value of $I_f(s)$ we have
$$N(s) = \frac{K_a V_f(s) - T_L(s)}{R_f(1 + s\tau_f)(Js + B)}$$

$$N(s) = \frac{V_f(s)(K_a / R_f B) - T_L(s)}{(1 + s\tau_f)(1 + s\tau_m)} \quad (2.23)$$

For field control system which is suitable for above base speed, the load torque is assumed to be small, so,
$$N(s) = \frac{V_f(s)(K_a / R_f B)}{(1 + s\tau_f)(1 + s\tau_m)} = \frac{N(s)}{V_f(s)} = \frac{K_m}{(1 + s\tau_f)(1 + s\tau_m)} \quad (2.24)$$

Field control method is a second order system.

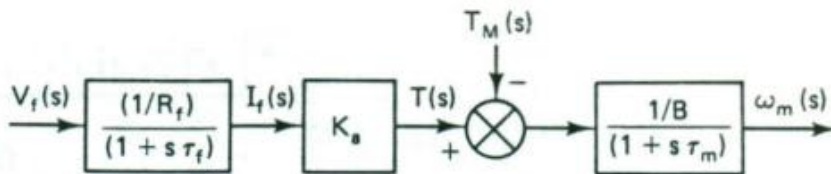

Block diagram of separately excited motor with field control.

Solid State Control

DC motor speed control by solid state can be done by two methods i) dc-dc Chopper control ii) Phasr rectifier control method

Chopper control of Dc motor drive: (separately excited)

This is one of the simplest power-electronic/machine circuits. With a battery, it is currently the most common electric road vehicle controller; the 'chopper' is also used for some d.c. rail traction applications. The principal difference between the thyristor-controlled rectifier and the chopper is that in the former the motor current always flows through the supply, whereas in the latter, the motor current only flows from the supply terminals for part of each cycle.

The chopper may use transistor,thyristor,MOSFET or IGBT as switches.

A single-switch chopper using a thyristor can supply positive voltage and current to a d.c. motor, and is therefore,restricted to quadrant 1 motoring operation. When regenerative and/or rapid speed reversal is called for, more complex circuitry is required,involving two or more power switches. When the motor voltage is less than the battery,the step down chopper is used and when the motor voltage is greater than the battery voltage, a 'step-up' chopper using an additional inductance as an intermediate energy store is used.

Function:

$$V_{dc} = V, CH1 \text{ on}$$

$$V_{dc} = 0, CH1 \text{ off}$$

$$D_1 \text{ on}$$

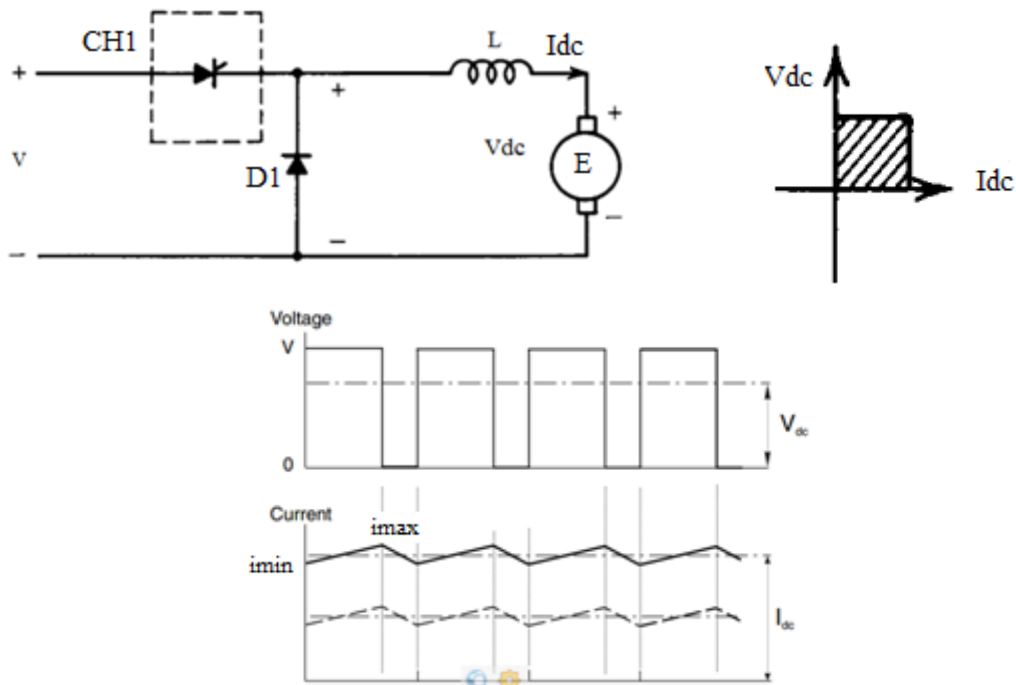

The shape of the armature voltage waveform reminds us that when the transistor is switched on, the battery voltage V is applied directly to the armature, and during this period the path of the armature current is indicated by the dotted line in Figure . For the remainder of the cycle the transistor is turned 'off' and the current freewheels through the diode, as shown by the dotted line in Figure. When the current is freewheeling through the diode, the armature voltage is clamped at (almost) zero.

The speed of the motor is determined by the average armature voltage, (V_{dc}), which in turn depends on the proportion of the total cycle time (T) for which the transistor is 'on'. If the on and off times are defined as $T_{on} = \delta T$ and $T_{off} = (1 - \delta)T$ where $0 < \delta < 1$, then the average voltage is simply given by

$$V_{dc} = \frac{1}{T} \int_0^{T_{on}} V dt$$

$$V_{dc} = \delta V \quad (2.25)$$

Where, $\delta = \frac{T_{on}}{T}$ duty ratio or time ratio and speed control is effected via the on time ratio, δ .

If we ignore resistance, the equation governing the current during the 'on' period is

$$V = E + L \frac{di}{dt} \quad \text{or} \quad \frac{di}{dt} = \frac{1}{L} (V - E) \quad (2.26)$$

During this 'on' period the battery is supplying power to the motor. So, the current rises.

During the 'off' period, the equation governing the current is

$$0 = E + L \frac{di}{dt} \quad \text{or} \quad \frac{di}{dt} = -\frac{E}{L} \quad (2.27)$$

So, the current fall. We note that the rise and fall of the current (i.e. the current ripple) is inversely proportional to the inductance, but is independent of the mean dc current, i.e. the ripple does not depend on the load. The current waveforms shown in Figure, the upper waveform corresponds to full load, i.e. the average current I_{dc} produces the full rated torque of the motor. If now the load torque on the motor shaft is reduced to half rated torque, and assuming that the resistance is negligible, the steady-state speed will remain the same but the new mean steady-state current will be halved, as shown by the lower dotted curve.

The average current I_{dc} further depends on the armature resistance that is

$$I_{dc} = \frac{\delta V - E}{R_a} \quad (2.28)$$

Now, the steady state speed of the motor is given by

$$\omega_m = \frac{\delta V}{K} - \frac{R_a}{K^2} T_a \quad (2.29)$$

Torque-speed characteristics

When the armature current is continuous the speed falls only slightly with load, because the mean armature voltage remains constant. But when the armature current is discontinuous (which is most likely at high speeds and light load) the speed falls off rapidly when the load increases, because the mean armature voltage falls as the load increases. Discontinuous current can be avoided by adding an inductor in series with the armature, or by raising the chopping frequency, but when closed-loop speed control is employed, the undesirable effects of discontinuous current are masked by the control loop.

Separately excited DC motor:

The torque-speed characteristics are drooping in nature as like in phase control. However, the drop in speed is less for chopper control than for phase control because of the nature of the supply voltage, which does not change with time. The region of discontinuous motor current operation can be reduced with chopper control by increasing the chopping frequency or introducing more inductance in motor circuit.

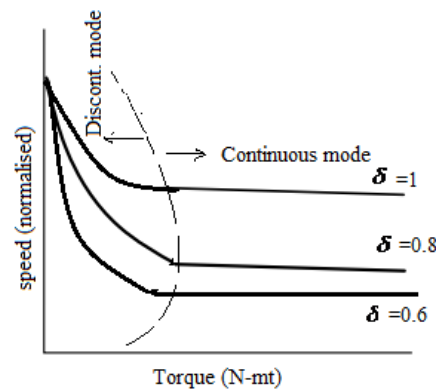

Regenerative braking (chopper drive)

Function

$$V_{dc} = 0, CH2 \text{ on}$$

$$V_{dc} = V, CH2 \text{ off } D_2 \text{ on}$$

The torque-speed curve is on second quadrant plane. So, regenerative braking takes place in second quadrant.

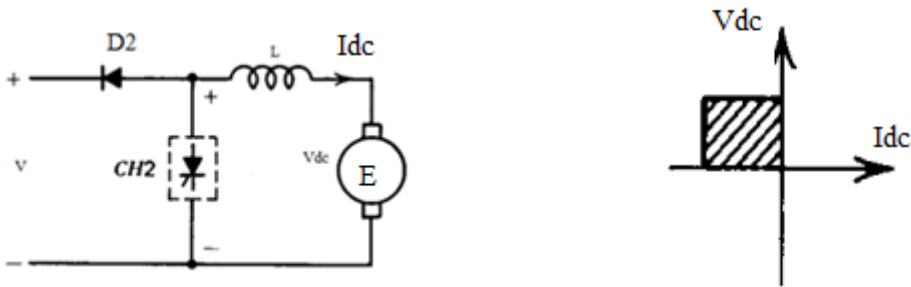

During turn on, the average voltage $V_{dc} = 0$ but, the current rises exponentially in motor circuit. During off, the average voltage $V_{dc} = \delta V$ and the current falls exponentially. The average current for this operation is

$$I_{dc} = \frac{E - \delta V}{R_a} \quad (2.30)$$

Since the torque is reversed, the torque is negative but the voltage polarity does not change.

$$T_b = -K I_{dc} \quad (2.31)$$

And speed is

$$\omega_m = \frac{\delta V}{K} - \frac{R_a}{K^2} T_a \quad (2.32)$$

Torque-speed characteristics for motoring and regenerative braking

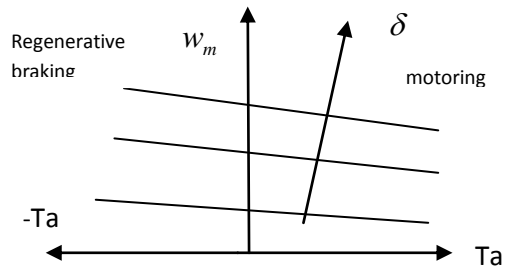

However, **both motoring and regenerative braking** can be brought into single chopper structure (two quadrant Type-A chopper or type-B chopper)

Type-A chopper

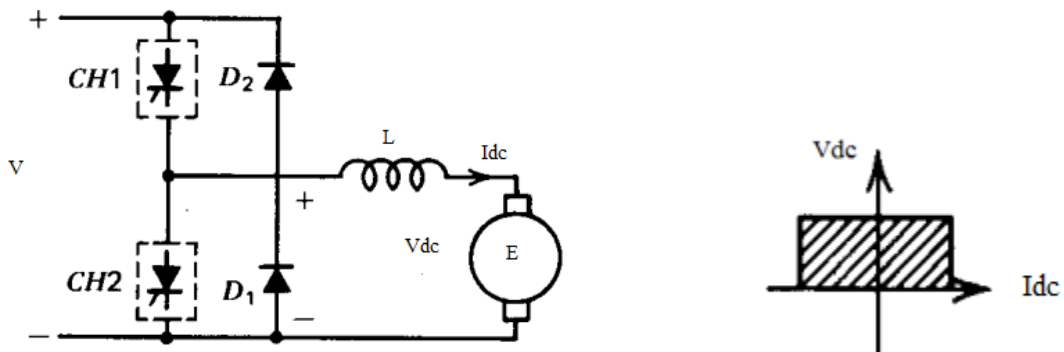

Function:

$V_{dc} = V, CH1$ or D_2 on
 $= 0, CH2$ or D_1 on $I_{dc} = positive$
 $CH1$ or D_1 on
 $= negative$
 $CH2$ or D_2 on

Type-B (two quadrant chopper)

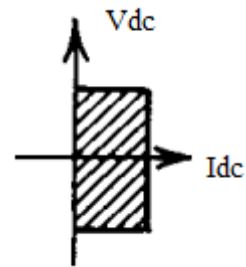
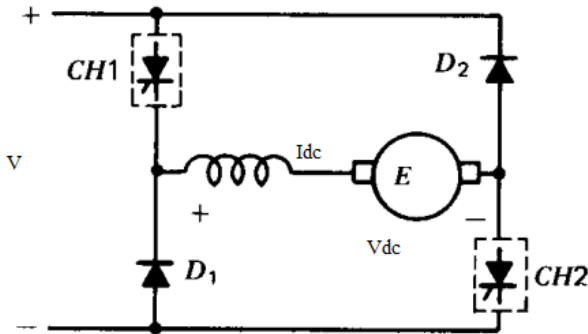

Function

$V_{dc} = +V, CH1$ and $CH2$ on

$V_{dc} = -V, CH1$ and $CH2$ off

D_1 and D_2 on

$V_{dc} = -V, CH1$

Fourth quadrant operation of Chopper fed Dc drive

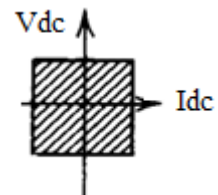
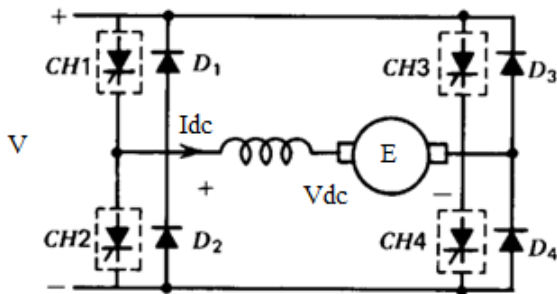

Function

$V_{dc} = positive$

$I_{dc} = reversible$

$CH4$ on and $CH3$ off

$CH1$ and $CH2$ operated

$V_{dc} = negative$

$I_{dc} = reversible$

CH2 on and CH1 off

CH3 and CH4 operated

Dynamic braking (chopper drive)

During dynamic braking, the supply is taken away and the braking resistance R_b is connected across the supply terminal. Now, before the supply is disconnected the switch (chopper) is made on. The stored kinetic energy is made to pass through the switch, and the motor parameters. Then the braking resistance is connected and the switch is made open. So, the energy is made to pass through the diode and braking resistance. The current is flown in reverse direction and the braking torque is developed.

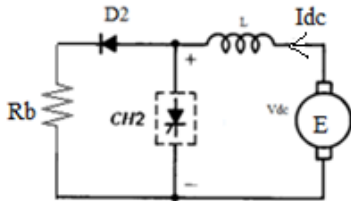

$$\text{The energy consumed by the braking resistance of chopper is } E_b = I_{dc}^2 R_b (T - T_{on}) \quad (2.33)$$

$$\text{Average power consumed by } P = \frac{E_b}{T} = I_{dc}^2 R_b (1 - \delta) \quad (2.34)$$

$$\text{Effective value of braking resistance is } R_b = \frac{P}{I_{dc}^2} = R_b (1 - \delta) \quad (2.35)$$

Phase controlled converter for speed control

There are a number of controlled rectifier circuits, some fed from a 1-phase supply and others from a 3-phase supply. For the motor control, controlled rectifier circuits are classified as fully-controlled and half-controlled rectifiers. Single-phase controlled rectifiers are employed up to a rating of 10 kW and in some special cases up to 50 kW. For higher power ratings 3-phase controlled rectifiers are employed. As explained later in this chapter, the performance of a drive is improved when the rectifier pulse number is increased. Six-pulse operation is realized by employing the three-phase fully-controlled bridge rectifier. Twelve-pulse operation can also be obtained by connecting two six-pulse bridge controlled rectifiers.

Single-phase fully controlled rectifier (Two quadrant operation)

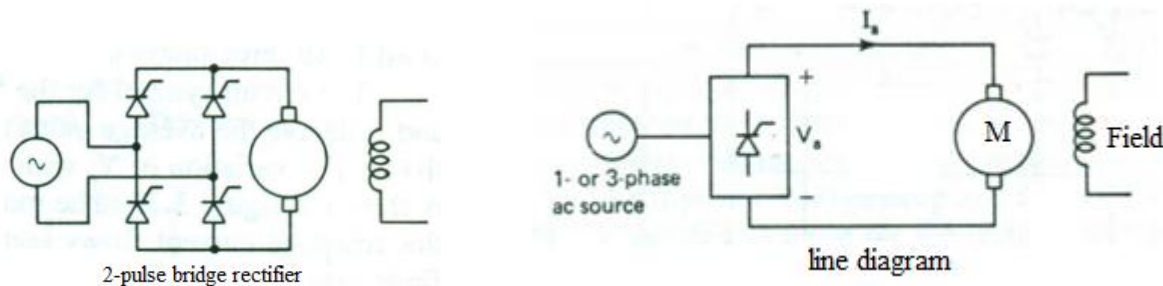

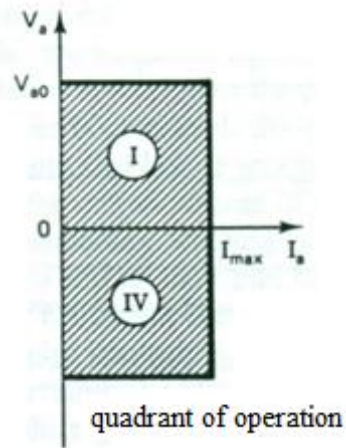
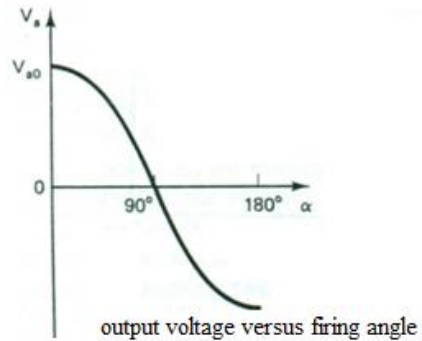

Let the output average voltage from the controlled ac-to dc converter is V_a and average current is I_a respectively. The variation of V_a with the firing angle α , assuming continuous conduction, is shown in figure. The motor is said to operate in continuous conduction when the armature current flows continuously - that is, it does not become zero for a finite time interval. The output voltage can be controlled from a full-positive ($+V_{a0}$) to a full negative ($-V_{a0}$) by controlling the firing angle from 0° to 180° . Since the output voltage can be controlled in either direction, the fully-controlled rectifiers are two-quadrant converters, providing operation in the first and fourth quadrants of the $V_a - I_a$ plane as shown. I_{max} is the rated rectifier current. With a negative output voltage, the rectifier works as a line-commutated inverter and the power flows from the load to the ac source.

Four quadrant operation (Closed-loop control)

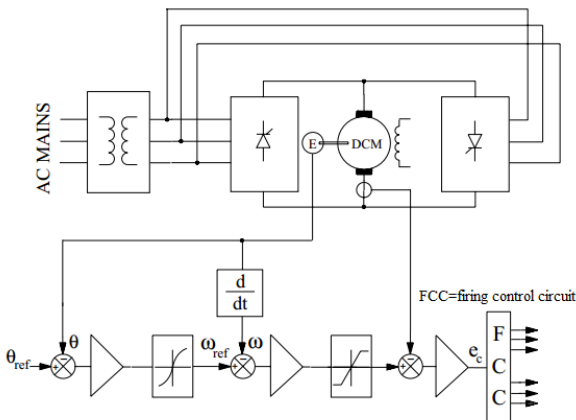

Bidirectional speed and position control system with a back-to-back (dual) thyristor converter.

A high-performance dc drive for a rolling mill drive may consist of such converter circuits connected for bi-directional operation of the drive. The interfacing of the firing control circuit to other motion-control loops, such as speed and position controllers, for the desired motion is also indicated. Two fully-controlled bridge ac-dc converter circuits are used back-to-back from the same ac supply. One is for forward and the other is for reverse driving of the motor. Since each is a two-quadrant converter, either

may be used for regenerative braking of the motor. For this mode of operation, the braking converter, which operates in inversion mode, sinks the motor current aided by the back emf of the motor. The energy of the overhauling motor now returns to the ac source. It may be noted that the braking converter may be used to maintain the braking current at the maximum allowable level right down to zero speed. A complete acceleration–deceleration cycle of such a drive is indicated in Fig. During braking, the firing angle is maintained at an appropriate value at all times so that controlled and predictable deceleration takes place at all times. The innermost control loop indicated in Figure is for torque, which translates to an armature current loop for a dc drive. Speed- and position-control loops are usually designed as hierarchical control loops. Operation of each loop is sufficiently decoupled from the other so that each stage can be designed in isolation and operated with its special limiting features.

Braking operation (separately excited dc motor)

A fully-controlled rectifier-fed dc separately excited motor is shown in figure. The polarities of output voltage, back emf, and armature current shown are for the motoring operation in the forward direction. The rectifier output voltage is positive and the firing angle is $0^\circ \leq \alpha \leq 90^\circ$. The motor can be made to work under regenerative braking if the armature current can reverse. This is not possible because the rectifier can carry current only in one direction. The only alternative available for the reversal of the flow of power is to reverse both the rectifier output voltage V_a and the motor back emf E with respect to the rectifier terminals and make $E > V$

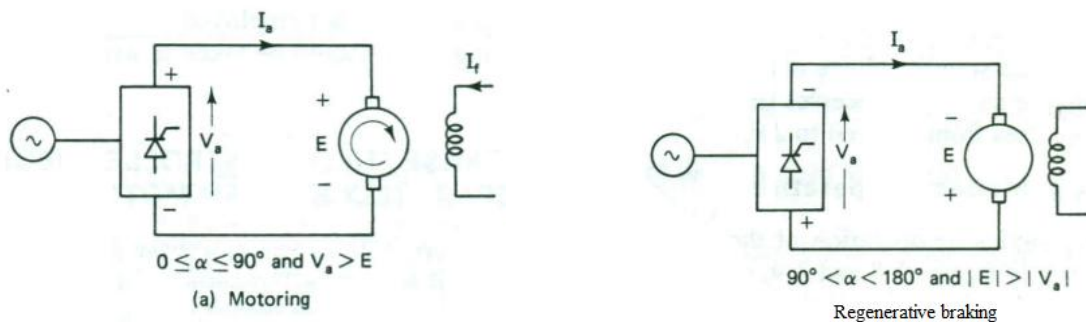

The reversal of the motor emf with respect to the rectifier terminals can be done by any of the following changes:

1. An active load coupled to the motor shaft may drive it in the reverse direction. This gives reverse regeneration (that is, operation in quadrant IV of the speed-torque plane). In this case no changes are required in the armature connection with respect to the rectifier terminals.
2. The field current may be reversed, with the motor running in the forward direction. This gives forward regeneration. In this case also no changes are required in the armature connection.
3. The motor armature connections may be reversed with respect to the rectifier output terminals, with the motor still running in the forward direction. This will give forward regeneration.

Steady-State Motor Performance Equations (continuous conduction)

For the purpose of analysis, the following assumptions are made:

1. Thyristors are ideal switches—that is, they have no voltage drop when conducting and no leakage current when blocking. The main implication of this assumption is that the rectifier voltage drop and losses are neglected. This assumption should not be used with low-voltage motors.

2. The armature resistance and inductance are constant. The skin effect, which is present due to a ripple in the motor current, does alter the value of the resistance.
3. During a given steady-state operation, the motor speed is constant. The motor torque does fluctuate due to the ripple in the motor current. Because the mechanical time constant is very large compared to the period of current ripple, the fluctuation in speed is in fact negligible. At constant speed, one can assume the back emf E is an ideal direct voltage for a given steady-state operation.
4. Source inductance is negligible.

The rectifier output voltage consists of one or two of the following intervals:

1. Duty Interval
2. During this interval

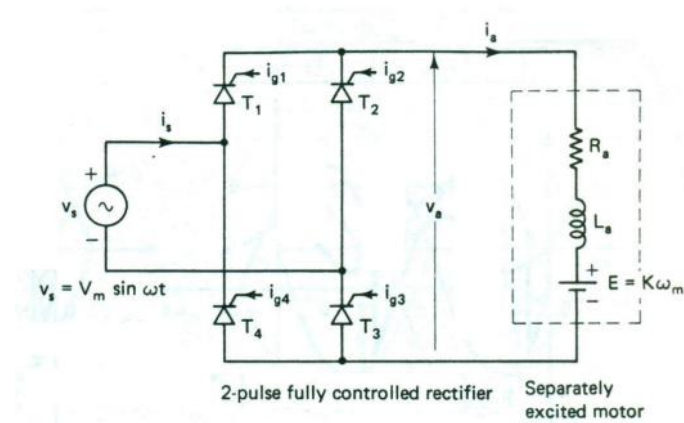

Duty Interval. When T1 and T3 conduct

$$v_a = L_a \frac{di_a}{dt} + R_a i_a + K\omega_m = V_m \sin wt \quad (2.36)$$

When T2 and T4 conduct

$$v_a = L_a \frac{di_a}{dt} + R_a i_a + K\omega_m = -V_m \sin wt \quad (2.37)$$

Zero current Interval:

$$i_a = 0 \quad \text{and} \quad v_a = K\omega_m \quad (2.38)$$

The average voltage can be found considering the any one pair of switches during the duty interval

Average motor terminal voltage V_a = average voltage drop across R_a + average voltage drop across L_a + back emf

$$\text{Now } V_a = \frac{1}{\pi} \int_{\alpha}^{\pi+\alpha} V_m \sin wt d(wt) = \frac{2V_m}{\pi} \cos \alpha = V_{a0} \cos \alpha \quad (2.39)$$

$$\text{Where } V_{a0} = \frac{2V_m}{\pi}$$

From the motor equation

$$V_a = I_a R_a + K\omega_m \quad (\text{average voltage across } L_a \text{ is zero}) \quad (2.40)$$

$$I_a = \frac{V_a - Kw_m}{R_a} = \frac{\left(\frac{2V_m}{\pi} \cos \alpha\right) - Kw_m}{R_a} \quad (2.41)$$

Comparing eq. (2.39), (2.40) and (2.41)

$$w_m = \frac{2V_m}{\pi K} \cos \alpha - \frac{R_a}{K_2} T_a \quad (2.42)$$

Speed-Torque Characteristics

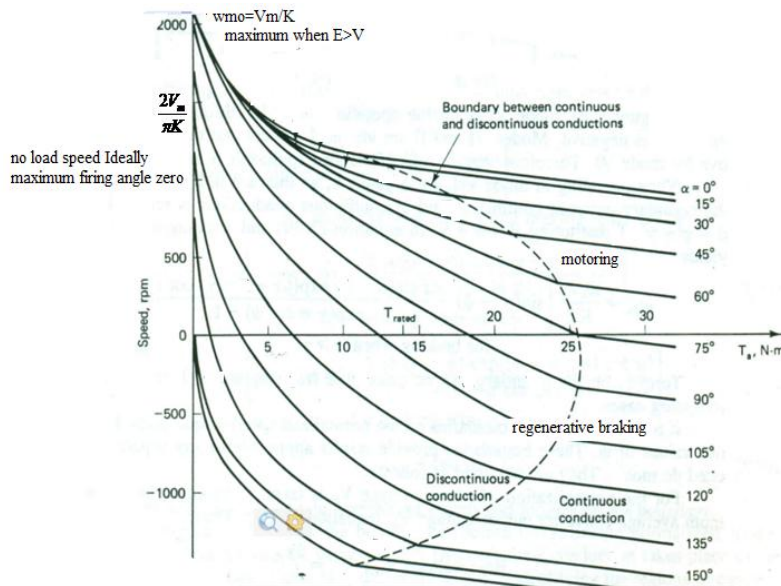

For torques less than the rated value, a low-power drive operates predominantly in the discontinuous conduction. In continuous conduction, the speed-torque characteristics are parallel straight lines, whose slope, according to equation (2.42), depends on the armature circuit resistance R_a . The effect of discontinuous conduction is to make the speed regulation poor. In continuous conduction, for a given α , any increase in load causes E and W_m to drop so that I_a and T_a can increase. The average terminal voltage V_a remains constant. On the other hand, in discontinuous conduction, any increase in load, and the accompanied increase in I_a causes β to increase. Consequently V_a reduces, and the speed drops by a larger amount than in the case of continuous conduction. Other disadvantages of discontinuous conduction are the nonlinear transfer characteristics of the converter and the slower transient response of the drive.

Stability:

Stability of the closed-loop system can be checked by examining the frequency response of the open-loop system, the gain being adjusted to ensure (by means of design criteria known as gain and phase margins) that, when the loop is closed for the first time, there is no danger of instability. This is that if the d.c. loop gain is too high, some closed-loop systems exhibit self-sustaining oscillations. When a system behaves in this way it is said to be unstable, and clearly the consequences can be extremely serious, particularly if large mechanical elements are involved. Also unstable behavior is characteristic of linear systems of third or higher order. Whenever the closed-loop system has an inherently oscillatory transient response,

Cranes and Hoist Drives:

The Requirements of the Cranes and Hoist Drives are

- 1. The motion of the crane hook is in all three dimensions.**
- 2. In crane drives, the acceleration and retardation must be uniform. This is more important than the speed control.**
- 3. For exact positioning of the load creep speeds must be possible.**
- 4. When the motion is in the horizontal direction braking is not a problem. This is a problem if the load overhauls the motor in vertical motion. In the case of vertical motion the movement of the empty cage has to be carefully The speed must be constant while lowering the loads. The steady braking of the motor against cnierhauling must be possible.**
- 5. The drive must have high speeds in both the directions. The motor must have high speeds at light loads.**
- 6. Mechanical braking must be available under emergency conditions.**
- 7. Power lowering may be used when an empty cage or light hooks are**

The duty cycle of cranes depends upon some requirements. These are:

- it must be able to perform strenuous duty**
- it must withstand high ambient temperature**
- it must be able to work in a dusty atmosphere**
- it must provide trouble free operation**
- it should have rigid safety measures.**

Cranes and Hoist Drives are classified depending upon the nature of duty they have to perform and also the duty cycle.

These are light duty, medium duty, heavy duty and continuous duty

Drive Motors for Cranes and Hoist Drives

The crane motors can be either dc or ac motors.

Even though the electrical characteristics make dc motors suitable as crane motors, the lower inertia and simple and economical construction of cage motors favour them as crane motors. With the advent of thyristors and associated power converters it is possible to have torque control during starting, running and braking.

DC Systems for Cranes and Hoist Drives

Speed control is achieved by means of Ward Leonard system with all facilities of speed control in forward and backward directions with regeneration.

Among the dc motors, series motors are extremely suitable for crane operation. They have the following features:

- 1. They have very good starting torque, high torque capability at low speeds and light torques at high speeds.**
- 2. Power demand under highly loaded conditions decreases due to, fall in**
- 3. Electrical braking is possible even at low speeds due to low critical speeds.**
- 4. Very light conditions are not possible. Suitable changes may be made in the circuitry to make it to run at low speeds and light load conditions.**
- 5. The lowering speeds increase with the load. Regenerative braking is not possible to limit this speed. The speed of the empty cage can be limited by limiting the current to full load value.**

However, the speed-torque characteristics of dc series motors may be modified to suit all the phases of crane control, and are depicted in Fig. 7.6.

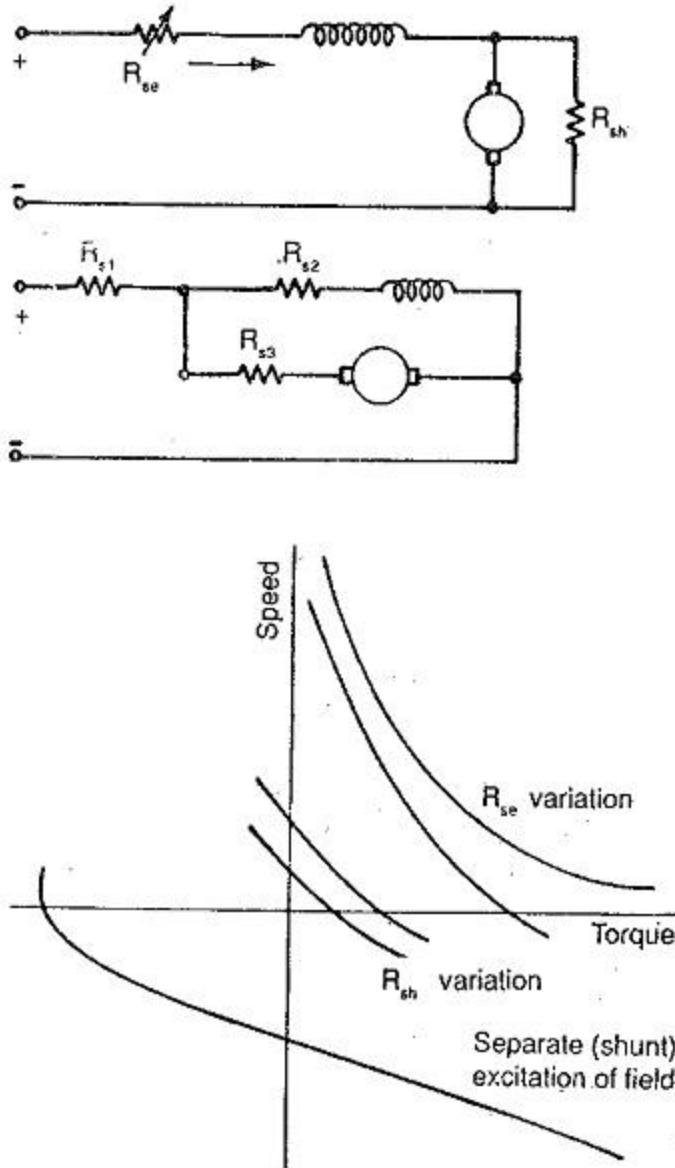

Fig. 7.6 Connection of series motor to have all phases of control

AC Systems for Cranes

Among ac motors, squirrel cage motors are normally used. They have the following features:

1. No speed control is required. However with the development of variable frequency converters which solve the problems of speed control of induction motor, inverter fed motors are used in situations requiring wide range of speed control.
2. They have fast acceleration and a fixed sequence of operation.
3. Regenerative braking is not a problem. This occurs automatically when the load overhauls or the empty cage is being raised.

4. The Motor is simple and robust

These are not suitable when a large number of startings and brakings are required. A starting torque up to 250% of full load torque may be obtained. In cases of very high starting torque these are not suitable. Non-uniform sequence of operation cannot be handled and conventional methods of speed control are not suitable if precise speed control is necessary.

Slip ring induction motors for cranes and hoists have the following features:

1. The speed-torque curve can be modified by suitably altering the rotor resistance. The starting torque can also be varied to the required value.

Regeneration is possible. Reverse current braking can be employed limiting the current to the desired value by rotor resistance. DC dynamic braking may also be employed. While selecting a motor for crane duty the following points require consideration:

1. Breakdown torque must be greater than 250% (in the range of 275-300)

2. The inertia must be small.

3. It must withstand large frequency of starts.

4. The motor must have sufficient running torque, starting torque and thermal capability for the given duty cycle.

Drive Considerations for Textile Industry:

There are several processes involved by the time the finished cloth comes out of a mill from its basic raw material, cotton picked up from the fields. The requirements of the motors are different for different processes. These mainly depend on the nature of the process. The several stages in the Textile Industry and the requirements of a drive motor for each stage are discussed in the following:

Ginning: The process of separating seeds from the raw cotton picked from the field is called ginning. This may be done in the mills located near the fields or in the industrial location itself. In the former the ginned cotton is transported to the industrial area in the form of hales. The ginning motors must have speed ranges of 250 to 1450 rpm. The load speeds are fairly constant. No speed control is required.

Commercially available squirrel cage induction motors may be employed.

Blowing: The ginned cotton in the form of bales is opened up and is cleaned up very well. Normally three phase Induction Motor may be used for the purpose. No speed control is required. The motors having synchronous speed of 1000 or 1500 rpm may be employed.

Cording: The process of converting cleaned cotton into laps is done by lap machines which are normal three-phase standard squirrel cage motors. These laps are converted to slivers by a process called cording. A motor used for cording is required to accelerate a drum having a large moment of inertia. It is required to withstand prolonged accelerating periods. To meet these requirements the motor selection must be made. The motor selected must have a very high starting torque and low starting current so that starting losses are kept to a minimum. The motor must have sufficient thermal capacity to withstand the heat produced by the losses occurring during prolonged acceleration. These cord motors are standardised in IS:2972 (part II) 1964 which gives the specifications for cord motors.

Normally, three-phase totally enclosed or totally enclosed fan cooled squirrel cage induction motors with high starting torque may be employed. The rating of the motor depends upon the type of fabric. Smaller rating motors in the range 1.1 to 1.5 kW may be used for light fabric. For heavy fabric the rating increases to 2.2 to 5.5 kW. The operating speeds of these motors are in the range 750-1000 rpm. Squirrel cage motors (8/6 poles) having synchronous speeds in the range of 750-1000 rpm are normally employed. The motors may be started directly from the line to achieve good starting torque. Slip ring motors may be advantageously used with rotor resistance starters as they give high starting torque at low starting currents. Once started the operation is continuous and uninterrupted.

These slivers are converted to uniform straight fibre by means of drawing machines. These are also normal standard motors. However, the motor selected must be capable of stopping instantaneously, in case of sliver breaking. The drawing machines are sometimes self brake motors which satisfy this requirement. The motor is subjected to inching to place up the broken sliver again. The inching operations may amount to 20. When the brake forms an integral part of the motor there is no necessity for a clutch and the motor becomes compact.

Combing and lap operations take place after slivers are straightened in a drawing machine. The motors used for these operations are also normal squirrel cage motors. The combing process upgrades the fibre. The slivers are converted into laps before combing.

The next process is spinning. Before the thread is ready for final spinning it is thinned down in two or three stages by processing it on a fly or speed frame. A motor with smooth acceleration is necessary to give Considerations for Textile Industry in this frame. The drive motor should be capable of working in high ambient temperatures. The motor must be totally enclosed, with a clean floor construction. This is to prevent the cotton fluff from getting deposited on the motor surface, which may lead to poor cooling of the motor as well as burning of fluff due to motor heating. The motor must have uniform acceleration having thermal reserve.

During spinning process the yarn is twisted and made to have sufficient strength. These spinning motors are standardised in IS:2972 (part III) 1965, which gives the specifications for spinning motors. The strengthened yarn is wound on bobbins. The spinning motor must be capable of drawing, twisting and winding operations. The breakage must be minimum and the yarn produced must have uniform tension. These motors also must have uniform acceleration to avoid yarn breakage. For a motor to have uniform acceleration, its speed-torque characteristic must be as shown in Fig. 7.1.

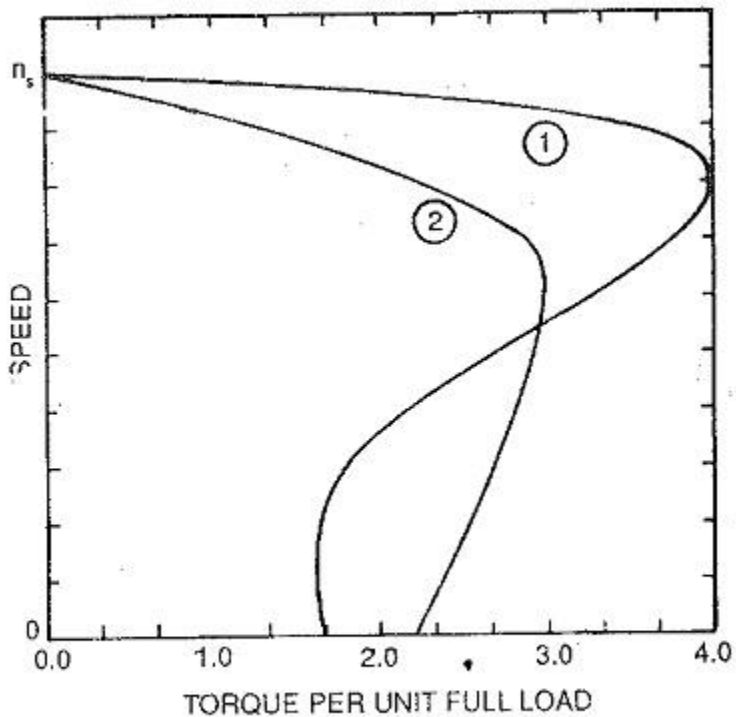

Fig. 7.1 Typical speed-torque of spinning motor for uniform acceleration
 ① Normal motor ② Spinning motor

Its starting torque must be 150-200% and the peak torque 200-250%. The difference between these torques must be constant as the motor speeds up and must be small to ensure uniform acceleration. The acceleration is also slow and smooth. This is to avoid yarn breakage. A normal motor is, therefore, not suitable for this process. The motor must have an acceleration time of 5 to 10 s. The operating speed is 500 rpm. The kW rating of the motor is decided by ring frame; number of spindles, ring diameter and spindle speed. When once the initial build is over the motor may run at a higher speed. A two speed pole change motor may be used. It must have constant torque operation at both the speeds so that uniform tension is assured both at starting and running. One can employ two different motors, one for starting and low speeds and the other for high speeds. In either case the motors are costly. Two speed pole change motors are bulky and costly. However, the increased uninterrupted production may compensate for the cost. A two motor drive is also costly but has several advantages. It allows setting of any speed difference by adjusting the pulley diameters and speed ratios. The yarn tension can be adjusted independently. There is no interruption in production even when one motor fails.

For mule spinning, a group drive may be employed. The motor employed should have high starting torque as well as high operating slip. A slip ring motor with rotor resistance control or high torque cage motors may be employed for the purpose. When an individual drive is used, the motor chosen should be able to take care of peak power demands and must have higher slip.

For operations like winding, warping and sizing, normal motors may be employed. Low speed motors are required. Reduction in speed using a gearing unit may be accomplished. When the yarn is transferred from the bobbin, a speed drop of nearly 100 rpm is required. So for these operations high slip motors are preferred.

Looms: The weaving of yarn into cloth is done in looms. The drives may be either semi group drives or individual drives depending upon the quality of the cloth required. The speed of operation is normally 600 to 750 rpm. Requirements of a loom motor are:

1. **Starting torque must be high to complete the pick up job in a very short**
2. **The duty cycle consists of frequent starting and stopping. The load on the loom motor is variable and intermittent. To avoid frequent starting and stopping the motor may be decoupled (or coupled) from the load by means of a clutch.**

3. **The operation requires a reciprocating mechanism. Actually rotary motion must be converted to linear reciprocating motion. The current and torque pulsations are present. A flywheel is required for smoothing.**
4. **These are also located in places where dust accumulates on the motor. The cotton fluff should not get collected on the motor surface to avoid burning of the same due to motor heating.**
5. **Loom motors must withstand the effects of humidity.**

To suit to the above requirements the loom motors are normally totally enclosed three-phase induction motors with high starting torque. Fan cooling of the motors is also employed. The fan cooling helps to avoid the collection of cotton fluff on the motor surface. The motor must be designed, taking into consideration the possible torque and current pulsations due to reciprocating motion. The surface of the motor must be such that it does not collect any cotton fluff. The kW rating of the motor selected must be decided taking into account the frequent starting and stopping in the duty cycle. The size of the loom motor depends upon the fabric. For light fabric, motors of rating up to 1.5 kW and for heavy fabrics motors of rating 2.2 to 3.7 kW are employed. Speeds of **motors** are in the range of 100 to 750 rpm. Brake motors may be used here so that motor stops automatically in case the thread breaks.

Features of Stepper Motor:

The Features of Stepper Motor are

- **small step angle**
- **high positioning accuracy**
- **high torque to inertia ratio**
- **stepping rate and accuracy**

Small Step Angle: The angle by which the rotor of a stepper motor moves when one pulse is applied to the (input) stator is called step angle. This is expressed in degrees. The resolution of positioning of a stepper motor is decided by the step angle. Smaller the step angle the higher is the resolution of positioning of the motor. The step number of a motor is the number of steps it makes in one revolution. The stepper motors are realisable for very small step angle. Some precision motors can make 1000 steps in one revolution with a step angle of 0.36° . A standard motor will have a step angle of 1.8° with 200 steps for revolution. The step angles of 90° , 45° , 15° are not uncommon in simple motors.

High Positioning Accuracy: The quality of a stepper motor is decided by its positioning accuracy. This accuracy of positioning is a significant factor. In any application the stepper motors are expected to rotate by step angle when a pulse is

given as input. It should come to rest in a precise position. Care must be exercised in the design and manufacture of a stepper motor as the accuracy at no load depends on the physical accuracy of the rotor and the stator. The positioning accuracy depends only on the machine characteristics and the driving circuit, while other electronic parameters have no effect on positioning accuracy. The stepper motors are designed to have very high restoring torque when the rotor is displaced following load torque.

High Torque-to-inertia Ratio: A stepper motor must move fast response to a pulse or a train of pulses. Fast response is also associated with quick start and quick stop of the motor. The motor must be capable of stopping at a position specified by the last pulse of the pulse train if the train is inhibited when the motor is running uniformly. A stepper motor must have a large ratio of torque to inertia

Stepping Rate and Pulse Frequency: The speed of a stepper motor is indicated by the number of pulses per second. Stepping rate of the motor is therefore used to indicate the speed. As the motor moves by one step for a pulse the speed can also be indicated by pulses per second as pulse frequency. The absolute rotational speed and stepping rate are related by

$$n \text{ (rpm)} = 60 f/S,$$

Where,

S = step number,

Solar and Battery Powered Drives

Solar and Battery Powered Drives:

Battery Powered Vehicles:

Battery Powered Vehicles – These are popularly known as electric vehicles. Although several batteries and fuel cells have been developed, only available at affordable price is the lead acid battery. Therefore, electric vehicles are generally powered by lead acid batteries. Series and separately excited dc motors, permanent magnet dc motor, brushless dc motor and induction motor have been used in electric vehicles.

The advantages of electric vehicles (EV) over the internal combustion vehicles (ICV) are:

- Less pollution.

- Quieter operation.
- Less maintenance: The electric drive being simple requires hardly any maintenance. Unlike ICV, EV has no water cooling system to maintain, no filters, belts, or hoses to replace, or no oil to change.
- More reliable: Due to the presence of fuel injectors, compressors, pumps and valves, water cooling system, filters, an internal combustion engine is lot more complex compared to an electric drive, and therefore, less reliable.

The disadvantage are:

- More expensive.
- EV cannot go nearly as far on a single charge as comparable ICV can go in a tank of fuel.
- It takes much longer to recharge electric vehicle's battery than it does to fill a petrol tank.

Voltage employed have typical values of 6 V, 12 V, 24 V, 48 V and 110 V. Higher voltage yields a motor with less weight, volume and cost, but then battery cost becomes high.

Regenerative braking is usually employed. It increases the range of vehicle by 7-15%. The regenerative braking does not have any braking torque at zero and close to zero speed. Therefore, mechanical brakes have to be employed with regenerative braking. The braking system should then be designed to provide coordination between regenerative braking and mechanical brakes.

A permanent magnet dc motor drive for a Battery Powered Vehicles is shown in Fig. 9.11. The drive employs chopper control with regenerative braking facility. L_F and C_F filter is employed to filter out chopper control with regenerative braking facility. L_F and C_F filter is employed to filter out the harmonics generated by the chopper. MS is a manual switch and RS a reversing switch. Inductance L is provided to assist regeneration and keep the ripple in motor current low.

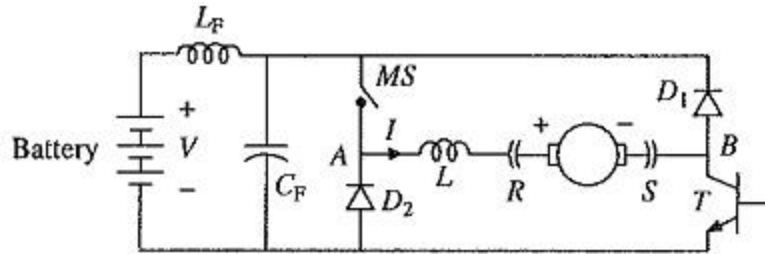

Fig. 9.11 dc drive with chopper control for EV

Motoring Operation:

For motoring operation MS is kept closed. Transistor switch T is operated at a constant frequency with variable on time to obtain variable dc voltage for starting and speed control. When T is on, the current flows through the source, L_F , MS, L, R, armature, S and T. When T is off, the armature current freewheels through S, D_1 , MS, L and R.

Regenerative Braking Operation:

For regenerative braking operation MS is kept open and motor armature is reversed with the help of the reversing switch RS making B positive with respect to A. When T is on, the armature current builds up through the path consisting of T, D_2 and L. When T is off, the armature current flows against the battery voltage through the path consisting of D_1 , L_F , battery, D_2 and L and the energy feedback is utilized to charge the battery.

The drive is operated with closed-loop current control. As the torque is directly proportional to the current, this gives closed-loop torque control. By appropriately controlling the torque the driver sets the vehicle speed at a desired value. The chopper drive of Fig. 5.44 is also used in EV.

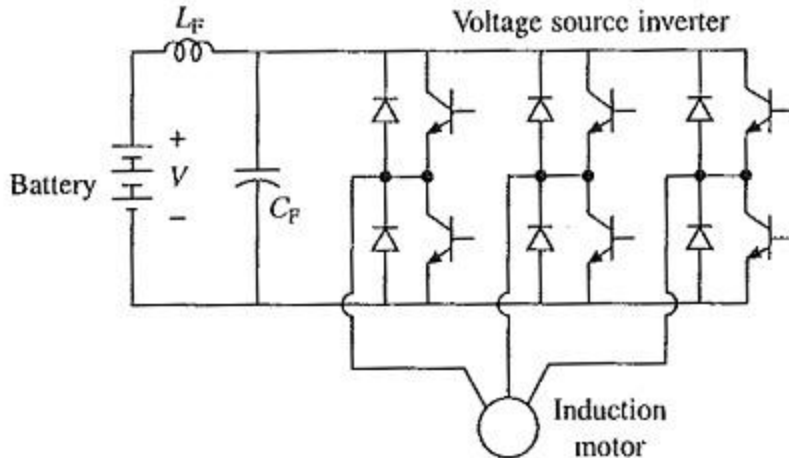

Fig. 9.12 Induction motor drive with voltage source inverter control for EV

Figure 9.12 shows the induction motor drive for Battery Powered Vehicles. It employs squirrel-cage motor fed from a pulsewidth modulated voltage source inverter. It has inherent capability for regeneration. One has to just reduce the inverter frequency, to make the rotating field speed less than the rotor speed for the operation to shift from motoring to regenerative braking. The drive has all the advantages of induction motor. Because of pulsewidth modulation, drive is efficient and the ride smooth.

Solar Powered Pump Drives:

Solar Powered Pump Drives: Centrifugal and reciprocating. Their speed-torque characteristics are shown in Fig. 9.3. Centrifugal pump requires only a small torque to start whereas reciprocating pump owing to stiction may require as much as three times the rated torque. In centrifugal pump the output power is proportional to the cube of speed, and therefore, drastically reduces as the speed is reduced; for example, the output power reduces to half at a speed of 80%. In reciprocating pump, since with a reduction in speed the torque reduces only by a small amount, the percentage reduction in output is slightly more than the percentage reduction in speed.

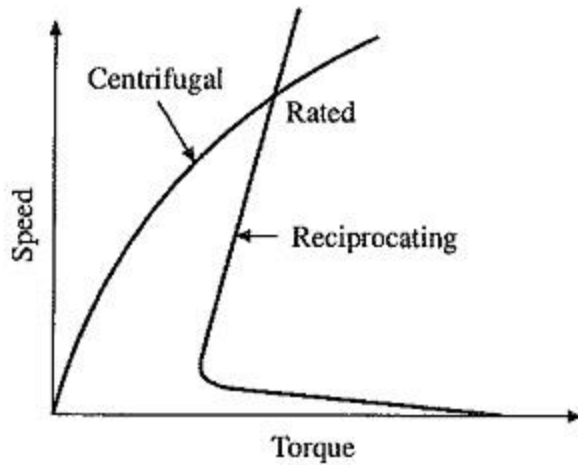

Fig. 9.3 Speed torque characteristics of centrifugal and reciprocating pumps

A simple scheme of Solar Powered Pump Drives using a permanent magnet dc motor is shown in Fig. 9.4. The solar panel directly feeds the motor. One can connect the solar cells to form a low-voltage-high-current or low-current-high-voltage unit. A low current-high-voltage arrangement is preferred because of lower proportion of losses in the motor and solar panel. However, a dc voltage more than 80 volts may present a serious electrocution hazard and should be avoided. Since the solar cells themselves regulate the maximum output current no starter is required for the dc motor.

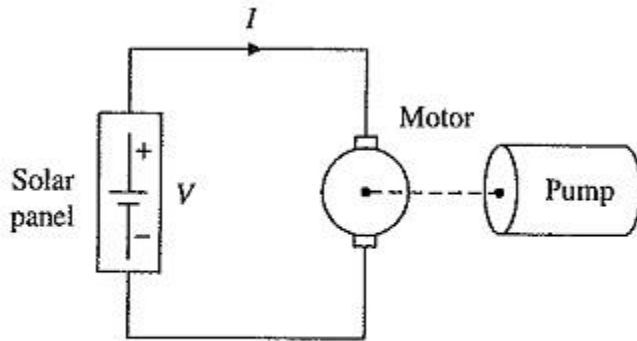

Fig. 9.4 Solar pump drive employing permanent magnet dc motor

Noting that in a permanent magnet dc motor, the torque is proportional to armature current and back emf proportional to speed, the motor speed-torque characteristics for different insulation levels can be obtained from Fig. 9.2. These are shown in Fig. 9.5. For the optimum utilization of solar panel, the operation should take place at the maximum power points. This is not possible in the simple drive of Fig. 9.4. However, in case of centrifugal pump, the parameters of motor and pump can be

matched so that the solar panel operates close to the maximum power points as shown in Fig. 9.5. Points corresponding to maximum power points of the solar panel are shown by 'x'.

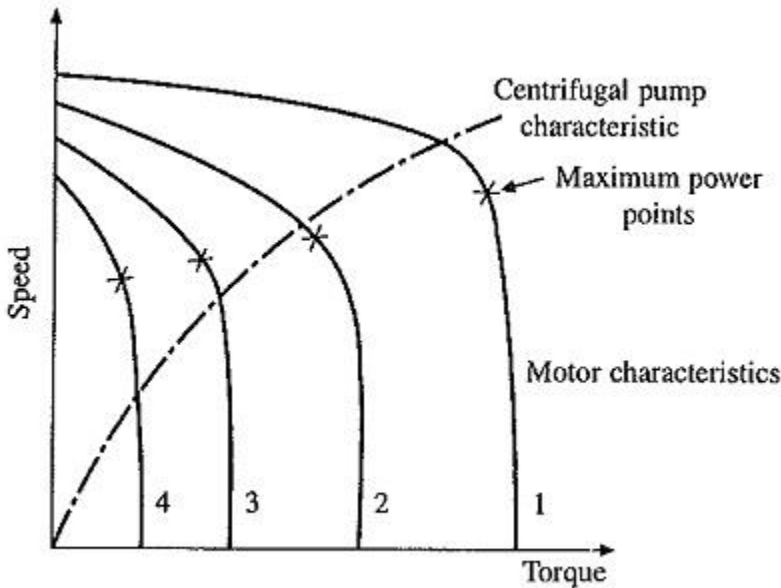

Fig. 9.5 Matched solar panel and drive characteristics

Better utilization of solar panel is obtained by reconnecting solar cells, as explained with the help of Fig. 9.6. Characteristics 1 to 4 correspond to normal connection. The panel operates close to maximum power points with insolation levels corresponding to characteristics 1 and 2. By reconnecting the solar cells so that there are more units in parallel and less in series, the characteristics 3 and 4 can be modified to characteristics 3' and 4', which then provide operation closer to the maximum power points compared to the simple scheme of Fig. 9.4.

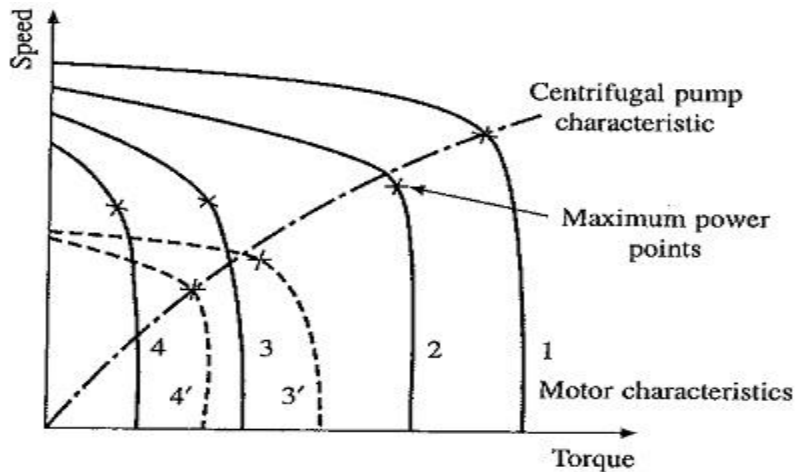

Fig. 9.6 Matching of solar panel and drive characteristics by reconnection of solar cells

For better matching a step-down chopper is inserted between the solar panel and the motor. With the help of the maximum-power point tracker, the duty ratio of the chopper is varied to obtain the solar panel operation at the maximum power-points for all insolation levels. The circuit for this is shown in Fig. 9.7. It should, however, be noted that the addition of one more power stage (i.e. chopper) increases the losses. Thus, although this scheme permits the extraction of the maximum power from the solar panel, because of the increase in losses, the power supplied to the pump may not increase significantly. Therefore, for a given application, calculation should be done for the losses and additional power output, so as to decide whether the chopper and maximum power point tracker should be employed or not. Use of the chopper and maximum power-point tracker offers an additional advantage. It ensures matching for all pump sites; although the pump parameters change with the change of site.

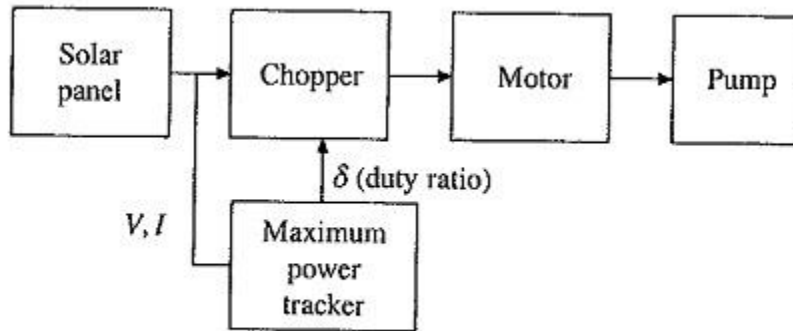

Fig. 9.7 dc motor drive with chopper and maximum power point tracker

If a reciprocating pump is used, then the pump characteristic relative to the characteristic-I of the motor will be as shown in Fig. 9.8. The characteristics of motor and pump have been adjusted such that at the rated conditions of the motor and pump, maximum power is taken from the solar panel at normal insolation level. Such a drive will fail to start. One solution to this problem is to use two sets of solar panels, which are normally connected in series. For starting they are connected in parallel. This changes characteristic-1 to characteristic-1' and the motor can now start because its torque exceeds stiction. This arrangement, however, does not allow operation near the maximum power points. Another alternative is to use a step-down chopper, which will allow the characteristic-1 to be modified to characteristic-1' as shown in Fig. 9.8. Now the motor can start. The step-down chopper in conjunction with the maximum-power-point-tracker will also ensure that the maximum available power is extracted from the solar panel. Starting in this manner will make it necessary to operate the chopper at low duty ratio and high current. Thus, a semiconductor switch with high rms current rating will be required. This disadvantage can be eliminated by giving a push to the pump

with the help of a rope and pulley arrangement to overcome stiction. The maximum power tracking control will however be necessary to ensure that the pump is also able to run at low insolation levels.

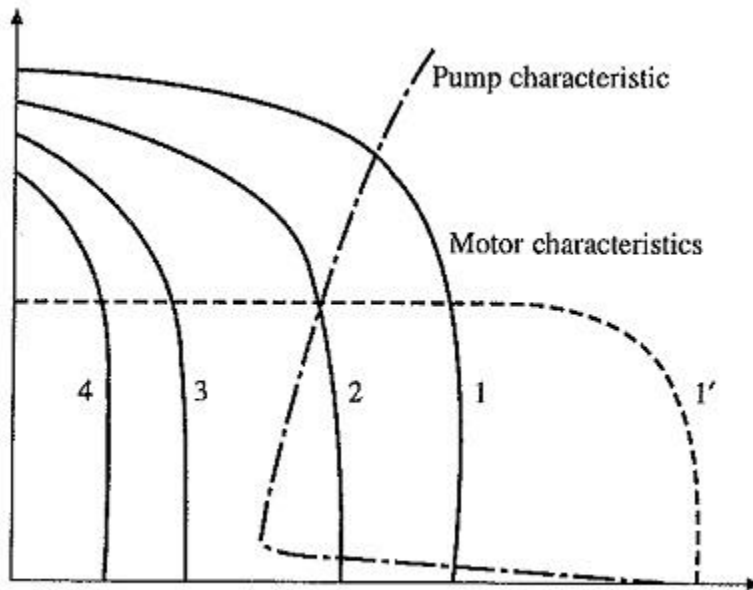

Fig. 9.8 Operation of the solar powered dc drive with reciprocating pump

The main objection to the dc motor drive is the presence of brushes which must be replaced after certain period, otherwise irreparable damage may be done to the motor. In view of this there is a need for improved brush material and construction such that the life of the brush will be long and after it wears, the motor will stop by itself.

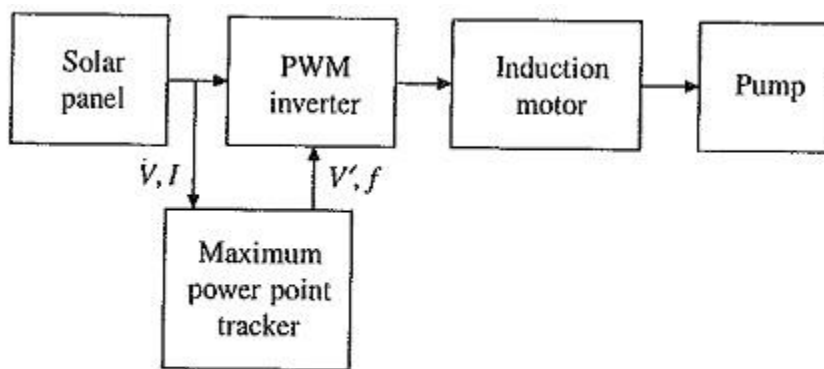

Fig. 9.9 Solar pump drive using induction motor

For pump ratings of 1 kW and above, three phase induction motor drive is employed. As shown in Fig. 9.9, a PWM voltage source inverter with maximum-

power-point-tracker is used for variable frequency control of the squirrel-cage induction motor.

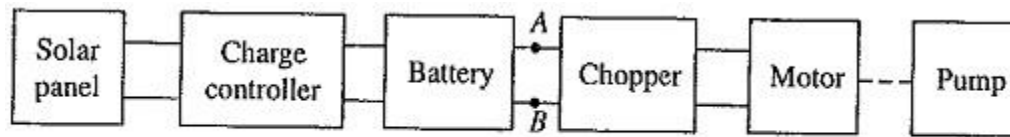

Fig. 9.10 Solar pump drive with a battery

Solar Powered Pump Drives with an intermediate battery, as shown in Fig. 9.10, can also be used. The drive is fed from the battery charged by solar panel.

Such a drive will have three advantages:

- It can be run without battery when some sunlight is available. With battery it can be run at a convenient time.
- In agriculture applications, it will generally run only for the part of a day, but the solar cells will be charging the battery for the whole day. Therefore, the solar panel rating can be substantially reduced, thus considerably reducing the cost of the drive.
- Battery drive can provide large torque. It is therefore suitable for reciprocating pumps necessary in some applications where high pressure is required, e.g. pumping water from deep wells etc.

Use of battery has two disadvantages:

- it requires frequent maintenance, which can be a serious problem in remote places and
- a charge controller is required to protect it from overcharge and excessive discharge.

An alternative to [battery](#) for agriculture pumps will be to utilise the drive during idle period to pump water in an overhead tank and to use this water under low insolation levels.

Types of Steel Rolling Mills:

Types of Steel Rolling Mills are either hot rolled or cold rolled. These may be either reversing type or continuous type. The motors used for reversing mills need operation in both the directions of rotation. A four quadrant operation of the motor may be required. In the continuous type the motor rotates only in one direction.

Types of Steel Rolling Mills, where the cross section of steel is transformed to required sizes, are classified depending upon the end product required. The choice of the motor to meet the requirements and the choice of the mill-stand depends upon the products required. In blooming mills the end product is slabbing mills produce slabs which are rolled metals of rectangular section. The blooms of reduced cross section are called billets which can further be rolled into bars, squares and angles. The mills that produce these materials of different sizes are called merchant mills. Slabs are converted to plates in plate rolling mills. These plates have less thickness than width. Strip mills convert these plates into strips which are transformed to sheets in a sheet mill. Cold rolling is normally used for producing sheets of good quality of uniform gauge. Hot rolling is used to make blooms, slabs and billets.

In reversing mills the steel is passed in the mill-stand in both directions alternately, till it reduces to the required size. In continuous mills, steel is passed in one direction through several stands which press the sheet simultaneously.

The finished sheets from cold rolling reversing mills may have a thickness ranging from 0.15 to 2 mm and more. Black plate produced in these mills may be of the order of 0.07 to 1.3 mm. The bands have a thickness of 0.0015 m and width 1 m. The production of sheet steel in a cold rolled mill is limited by low sheet speed because of the forward acceleration and retardation and adjustments of gaps in the mill-stand as the sheets are pressed. The production rate can be increased by passing the sheet in one direction.

The billets, strips, and the products of merchant mills are produced in continuous mills. Blooming and slabbing mills are of reversing type.

Reversing Hot Rolling Mills

Hot ingots from the soak pits or from steel making shops are rolled in these mills. These are transported to mill body by means of a car. A crane is used to load the

car with these ingots. The mill receives these ingots and processes them. The mill bed comprises a series of rolling mills.

The ingots are fed on the receiving table of the mill bed wherein they are weighed. Ingots travel on rolling mills. They reach the main mill-stand after passing through several tables, such as approach table, intermediate table, and front work tables. After the mill-stand there are tables such as backwork table, intermediate table and runout table. The finally finished steel is cut in a spear table to standard sizes. The length of the mill bed is decided by the length of the product.

The ingots are passed in the mill-stand in both the directions till they are pressed to desired thickness. As the thickness decreases, automatic adjustment of the gap is required, which is carried out by screwing down mechanism. This adjustment is made when the mill is made ready for reverse motion.

The metal at entry positions of the mills is aligned by means of manipulator slide guides.

Based on the process discussed above the nature of the drive is as follows:

1. **A wide range of speeds of operation is required. The duty cycle of the load has frequent starts and (stops) speed reversal. The motor and its control must be selected taking this into consideration. To increase the production rate the dynamic behaviour during speed reversal must be fast.**
2. **The direction of rotation must be reversible without causing serious disturbance to power handling circuits. The method employed should be such that the starting and speed reversal take place without any large dip in the terminal voltage.**
3. **Reliability and accuracy are imperative.**

The transport of ingots from the hot chamber to the car, conveying of the finished blooms or slabs, and the mechanical adjustments of the mill-stand are also carried out by several drive motors. These may be integrally controlled with the above mill-stand.

A motor selected should meet the above requirements. Its speed must be controlled over a wide range. The kW rating must be sufficient to drive the intermittent continuous load having the definite duty cycle with frequent starts and reversal. Braking may be required to stop the mill bed if required. Regenerative braking may not be advantageously employed. Plugging may not be suitable here due to peaks of current during speed reversal. These peaks cause voltage dips and hence

must be avoided. Accurate speed control using principles of automatic control is also possible and is a reliable method.

Ward Leonard control of dc motors is very much suitable here. The regenerative speed reversal is possible. Armature current control can be employed for fast retardation. Armature voltage variation in a smooth manner enables a wide range of speed control. Flux weakening of the motor increases this range on the upper side. Load equalisation is possible by means of a flywheel. The speeds can be very accurately set and the system has a very high reliability. This allows closed loop automatic speed control.

Ac motors with conventional methods of speed control are not suitable. An ac commutator motor may be used. But braking may have to be employed using the methods of plugging; dc dynamic braking has been done for normal three-phase motors. This may result in dips of supply voltage.

The advent of **thyristor power converters** has made the speed control of both induction and synchronous motors very simple. Ac motors employing a variable frequency supply for speed control may be employed. These are becoming competitors to dc motors. The cycloconverters have advantages at very low speeds over the dc link converters. So, cycloconverter fed synchronous motors are used very commonly for driving steel mills. The converters facilitate four quadrant operation. These drives meet all the requirements mentioned above.

Continuous Hot Rolling Mills

Billets or strips are produced in these mills. They operate in the forward direction only. The mill-stands are of two kinds here, roughing mills-stands and finishing mill-stands. These stands are also two or four high depending upon the number of rolls the stand has. In a four high stand inner rolls are smaller than the outer ones. The gap of rolling is maintained by the outer ones. The metal is worked simultaneously in the finishing stands. The roughing operation is not simultaneous,

The basics of the process described are

1. **When a mill has to produce billets of different sizes the gap between working rolls of the mill-stand must be adjustable.**
2. **To be able to reduce the thickness of the metal gradually the motors of consecutive mill-stands must have differing speeds. This requires that the motor must be capable of speed control in the range 1.5:2. Speed control should be accurate.**

- 3. The sag of the metal between two stands must be avoided. This sag may occur when there is a slight difference in the operating speed. The speed drop may occur due to sudden application of load, which normally happens when the metal comes into contact with the rolls. A closed loop control must assure quick restoration of the speed of the motor. The motor must have a very fast dynamic response to avoid sag.**

Based on the above, a motor to suit the job may be selected. The motor must have a constant speed at a given setting. It must have its speed controlled over a given range. The dc motors controlled by Ward Leonard control, ac commutator motors and ac motors fed from thyristor converters may be advantageously employed here.

Reversing Cold Rolled Mills

Another Types of Steel Rolling Mills is the metal in the form of a reel is used to feed the mill-stand. On one side of the mill-stand there is a delivering reel and on the other side there is a receiving one. The mill-stand may be two or four high. When the receiving mandrel is empty, the threading of the metal on to this empty one is done manually. The speed of the motor should increase with uniform acceleration, ensuring the required tension and pressure. Otherwise the sheet would break. The sheet is allowed through the mill-stand in both forward and backward directions till the metal of desired thickness is obtained.

The drive requirements immediately following the above process are the following:

- 1. The drive must be capable of reverse rotation. A four quadrant operation must be possible.**
- 2. One or two individually driven motors may be used. The work rolls may be driven directly. The back up rolls are provided with motion whereas the working rolls move by friction.**
- 3. The coiling motors besides the driving toilers ensure the desired tension of the strip between the toilers and mill-stand. This is necessary to prevent looping of the strip and/or breaking.**
- 4. The gap adjustment must be made simultaneously with the reversing. The latter is accomplished by screwing down the upper rolls.**
- 5. The inertia of the motor must be kept low and lower than that of the**
- 6. Torque control as well as speed control must be possible to maintain constant tension of the strip. In a dc motor the torque control is possible both by field control as well as armature current control. As the diameter of the roller decreases the torque must also decrease. This is**

achieved by field weakening in dc motors is limited by commutation and armature reaction effects. It is also limited by stability conditions of the motor. The armature current control may be employed beyond this limit.

7. The acceleration of the drive must be uniform to avoid breaking.

The motor selected for this purpose must have its torque developed, causing a smooth acceleration. It should be capable of four quadrant operation with smooth speed reversal. Torque control at different speeds must be possible. To suit these requirements, a versatile motor is a dc motor controlled by Ward Leonard control with flywheel effect. Static Ward Leonard control may become economical with the availability of thyristors at reasonable rates. Three-phase ac commutator motor or cycloconverter fed synchronous motors are suitable for the job.

Continuous Cold Rolling Mills

These work only in the forward direction and no reversing is required. The metal passes in one direction only in different stands till the product has the required thickness, The mill may be two high or four high. The coiler roller requires accurate torque and speed control. The strip tension must be constant and large. Low speed operation is required while threading the steel into the rolls. Immediately after the threading the speed of the motor must be increased. The speed must be brought down while the metal leaves the mill-stand. A large variation in the speed of the mill drive is required.

Motors for Mill Drive

Dc motors are very versatile as motors for mill drives due to their characteristics of high starting torque, capability for wide range of speed control, precise speed setting, large overload capacity and pull-out torque. Care must be taken to have satisfactory commutation in the complete working range. They can be accelerated, braked and reversed very fast. Further, the inertia of the motor must be very small. The motors for mill operations are normally TEFC motors with a high class of insulation.

The speed control of dc motors in Types of Steel Rolling Mills is accomplished by Ward Leonard control with flywheel effect. Dc dynamic braking may be employed for quick stopping and braking at a controlled rate. Sometimes mechanical brakes are also employed. Conventional Ward Leonard systems may be replaced by thyristorized units.

When smooth speed control is required, ac motors with conventional methods of **speed control** are not suitable. Ac commutator motor, such as Schrage motor may be employed. The thyristor power converters provide a variable frequency supply which can be used for speed control of ac motors. Both torque control and speed control are possible. For low speeds, cycloconverters can be used to give a smooth speed control. Thyristorized dc drives can be used in the place of Ward Leonard de drives.

Cement Mill Process:

The Cement Mill Process has different Stages in Cement Production and they are

The raw materials of Cement Mill Process are lime and silica. Alumina and ferric oxide are used as fluxing agents.

1. Collection of raw materials such as lime stone. This is transported to the mill site and crushed there if the quarry is far off. If the quarry is nearer it is crushed at the quarry itself and transported to the mill site.
2. Grinding of this crushed lime stone after the addition with bauxite, iron ore, etc. By passing air through bottom the lime powder is homogenised
3. This is fed to the cement kilns where the cement clinker is made at high The process where dry powder is used is called dry process.
4. Wet Cement Mill Process are also popular. Here the slurry is made by crushing or grinding the lime stone, bauxite with water. This is then fed to the kiln through the kiln feed tank.
5. Dry process is preferred to wet process due to the reduced quantity of fuel required. However the latter becomes economical if the materials are already wet and drying them may not be economical.
6. The hot clinker is then air cooled in special types of coolers and made ready for storage.
7. After storing for a few days gypsum is added in required quantities and ground to the required fineness.

Every stage has its own drive. Several drives in Cement Mill Process are raw mill drives, cement mill drives, kiln drives, crusher drives, waste gas fan drives and compressor drives.

Requirement of Mill Motors:

1. They should have high starting torque. The starting current must be limited to a maximum of two times full load value to minimise voltage dips. The

breakdown torque should also be high so that sufficient overload capacity is available.

2. An overload capacity of 50% for one minute may be necessary, occurring for four times in an hour.
3. Three starts from cold conditions and two consecutive starts from hot conditions per hour against full load.

These are very well met by a three-phase slip ring induction motor. Suitable starting torques may be accomplished at reduced starting currents by means of rotor resistance. The motor must have sufficient thermal rating to have frequent starts both under cold as well as hot conditions. The power factor may be improved by capacitor bank.

The power rating of the motor is rather high. As the motors have large power ratings and power transmission using gear boxes at this power level is not practical, two motors of identical capacity are used. Both of them may be equipped with identical rotor starters.

Gearless drives are preferable here. Gearless drives using the principle converters (Fig. 7.7) or dc link converters may also be used. As the price of thyristors is becoming less, these thyristorized drives are becoming very popular.

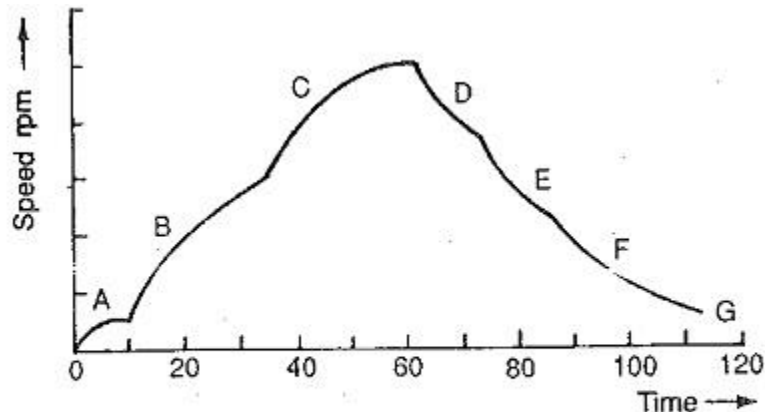

Fig. 7.7 A typical load cycle of a centrifuge A—Charging; B—Intermediate spinning; C—Spinning; D—E—F—Regenerative braking; G—Plugging for ploughing

Kiln Drives:

The rotary kiln drives depend upon the type of Cement Mill Process (wet or dry). These are, in general, tubular tilted from the horizontal position with a ring fitted around them. This ring gear engages with one or two pinions. A variable speed motor drives the pinion.

The requirements of a kiln motor are the following:

1. Power requirement is very high.
2. Speed control ratio is 1:10. Very low creeping speeds of 1 rpm may be required.
3. Starting torque should be in the range 200 to 250% of full load torque.
4. The acceleration of the drive should be completed in about 15 s.
5. For small periods an overload capacity of 200-250% may be required.
6. The motor must have suitable control for inching and spotting during maintenance.

The motors that meet the above requirements are ac commutator motors and Ward Leonard controlled dc motors. These have the disadvantage that the highest rating is limited by the commutator. Speed range is 1:2 in ac commutator motors whereas a speed range of 1:10 with crawling speeds is possible with dc motors. Capital outlay, lower efficiencies and limitations due to commutator, either in the Ward Leonard or ac commutator motors, may be overcome by the use of thyristorized drives. These have a wide range of speed control as against ac commutator motors.

When two motors are used to deliver the power they must be designed to have equal load sharing without overloading any one of them. They must maintain the same speed. They may be series connected or parallel connected with closed loop speed control

Converter fed dc motors in static Ward Leonard control have limitations on maximum operating speed and power rating due to the presence of a mechanical commutator. The ripple content in the armature current and possible discontinuous conduction further affect the commutating capability of the motor. Therefore for power ratings beyond this value, ac drives are suitable. Tubular mills for Cement Mill Process are very slow speed high power loads. A cycloconverter fed synchronous motor meets the requirements of a drive motor. The salient features of this system are:

1. The drive can be controlled to have an excellent dynamic behaviour with fast regenerative reversal.
2. The converter can be used for synchronous starting by varying the frequency with smooth acceleration up to desired speed. The disadvantages, such as peak starting current and consequent voltage dips in the supply, can be completely eliminated.
3. A continuous gearless drive is possible at crawling speeds.
4. A motor with self control has the characteristics of a dc motor with respect to both steady-state and dynamic behaviour. It is free from hunting. It is

mechanically strong, requiring little maintenance and can be built to have a rating several times that of converter fed dc motors. The low inertia of the motor is also responsible for the fast response.

5. A four quadrant operation is simple and straightforward.
6. Poor line power factor similar to that of converter fed dc motor.
7. Field weakening is possible above base speed.
8. The smooth speed control with minimal torque pulsations particularly at low speed is an added attraction, mainly when compared to synchronous motors or dc link converters.

Crusher Drives

The requirements of a crusher drive are as follows:

1. The starting torque is of the order of 160% of full load torque.
2. The breakdown torque is of the order of 200-250% of full load torque.
3. The rotor must be capable of withstanding a locked rotor current without limiting equipment, for one minute. This kind of situation may occur in case of jamming of the crusher due to very big boulders.
4. Adverse conditions of Loading may be encountered.
5. Overload capacity of 15% for 15 s and 20% for 10 s may be required. Slip ring induction motor with rotor resistance starters and speed control may be suitable for crusher drives. A dc chopper can be used to control the resistance.

Fan or Blower Drives

The drive motors are located in outdoor or semioutdoor locations. Totally enclosed fan cooled motors are suitable, depending upon the location of the motor. The torque requirements are: Starting torque is 120% full load torque; breakdown torque 200-250% full load torque.

Slip ring induction motors with rotor resistance control are suitable as drive motors. A subsynchronous converter cascade in the rotor circuit may also be employed for speed control. The latter has improved efficiency of operation. The following are the features of this drive:

1. The design rating of the converter depends on the speed range required. The converter must be capable of handling high currents at high speed and high voltages at low speed. Using a switchable converter cascade the rating may be decreased.
2. When the lowest speed is other than zero, starting equipment is required. Under emergency conditions the motor may be required to operate with this

resistance as a conventional motor. The resistance must be able to withstand the operation under running conditions.

3. The torque developed has pulsations and harmonics causing heating. A 12 pulse converter may be used to reduce these effects. The line side inverter presents several harmonics to the line which may cause the distortion of the input voltage to the stator.
4. It has a very poor power factor. Methods are available to improve the line p.f.

Compressor Drives

The drive motors for compressors have a rating in the range of 300-450 kW. Compressors have to be started on load or sometimes there may be means of unloading for starting. For starting on load, high starting torque is required. Normally care must be taken while choosing a starting equipment to limit the starting current. Starting current peaks are not permitted as they cause disturbances such as voltage dips. Totally enclosed fan cooled motors capable of operating in the speed range of 750-1000 rpm are employed.

Conventional squirrel cage motors may be used if starting on no-load can be accomplished. The starting method may be reduced voltage starting, to limit the starting current. If the compressor has to start on the load, high starting torque at reduced starting current may be required. A slip ring induction motor with rotor resistance starter may be used.

The ac drives making use of an induction motor or synchronous motor whose speed is controlled by means of a static frequency converter may also be used. These converters can be used for starting purposes also. They provide better starting conditions. A sufficient amount of accelerating torque with a current of 1.5 times full load current may be achieved. Locked rotor current and torque lose their significance and it is just sufficient to have reserve torque for acceleration. Consequently, voltage dips and the severe burden on the mains may be avoided. When synchronous motor are used, the line side converter uses line commutation and the machine side [converter](#) uses machine voltages for commutation. Therefore a simple converter is sufficient. Only at low speeds is the commutation assistance required.